



Model: 13694330200  
Type: SD100  
Engine: D6.7.1

# Owner's Manual

## Stationary Emergency Generator



**This manual should remain with the unit.**

# Table of Contents

<b>Introduction</b> .....	<b>1</b>	<b>Installation</b> .....	<b>13</b>
Read This Manual Thoroughly.....	1	STATIONARY EMERGENCY GENERATOR INSTALLATION.....	13
Operation and Maintenance.....	1	NFPA Standards.....	13
How to Obtain Service.....	1	Other Published Standards.....	13
Authorized Service Dealer Locator Number.....	1	BASIC STATIONARY EMERGENCY ELECTRIC SYSTEM.....	13
<b>Safety Rules</b> .....	<b>2</b>	EMERGENCY CIRCUIT ISOLATION METHOD.....	14
<b>General Information</b> .....	<b>4</b>	TOTAL CIRCUIT ISOLATION METHOD.....	14
IDENTIFICATION RECORD.....	4	GROUNDING THE GENERATOR.....	14
Data Label.....	4	GENERATOR AC NEUTRAL CONNECTIONS.....	14
Generator Set XPL Label.....	4	TRANSFER SWITCH START SIGNAL CONNECTIONS.....	14
EQUIPMENT DESCRIPTION.....	5	BATTERY INSTALLATION.....	14
Standard Generator Features.....	5	Vented Batteries.....	15
ENGINE PROTECTIVE DEVICES.....	5	PREPARATION BEFORE START-UP.....	15
Coolant Temperature Sender.....	5	Prior to Initial Start-up.....	15
Low Coolant Level Sensor.....	5	Start-up Inspection.....	16
Oil Pressure Sender.....	5	<b>Operation</b> .....	<b>16</b>
Overspeed Shutdown.....	5	GENERATOR CONTROL AND OPERATION.....	16
Overcrank Shutdown.....	5	OPERATING UNIT WITH MANUAL TRANSFER SWITCH.....	16
RPM Sensor Loss Shutdown.....	5	Engine Start-up and Transfer.....	16
DC FUSES.....	5	Retransfer and Shutdown.....	17
FUEL SYSTEM.....	6	OPERATING UNIT WITH AUTOMATIC TRANSFER SWITCH.....	17
Diesel Fuel System.....	6	<b>Maintenance</b> .....	<b>17</b>
SPECIFICATIONS.....	6	SERVICE SCHEDULE.....	17
Generator.....	6	Authorized Operator Maintenance Functions.....	17
Engine Oil Recommendations.....	6	Authorized Service Technician Maintenance Functions.....	17
Coolant.....	6	PERIODIC MAINTENANCE.....	18
Gearbox Lubrication.....	6	Test Stationary Emergency Generator System Operation and Components.....	18
Fuel System Requirements and Recommendations.....	7	Inspect Battery.....	18
BATTERY INSTALLATION.....	7	Check Fluids.....	19
THE BATTERY.....	8	Inspect Exhaust System.....	19
GENERATOR AC LEAD CONNECTIONS.....	8	Inspect/Test Fuel Supply System.....	19
Four-lead, Single-phase Stator.....	8	REPAIR PARTS.....	19
12-lead, Broad Range Stators.....	9	How to Order Parts.....	19
Six-lead, 600 VAC, Three-phase Stator.....	10	500 KW TO 600 KW STATIONARY EMERGENCY DIESEL ENGINE DRIVEN GENERATOR SETS.....	20
FIELD WIRING CONNECTIONS REQUIREMENTS.....	10	SERVICE MAINTENANCE INTERVAL INFORMATION.....	20
Field Wiring Connections to Buss Bars.....	11	<b>Notes</b> .....	<b>27</b>
GENERATOR AND LOAD COMPATIBILITY.....	11	<b>Warranty</b> .....	<b>29</b>
STARTING AIDS.....	11		
Engine Coolant Heaters.....	11		
Engine Oil Heater (Optional).....	11		
Battery Warmers (Optional).....	12		
Battery Chargers.....	12		

## INTRODUCTION

Thank you for purchasing this model of the stationary emergency generator set product line by Generac Power Systems, Inc..

Every effort was expended to make sure that the information and instructions in this manual were both accurate and current at the time the manual was written. However, the manufacturer reserves the right to change, alter or otherwise improve this product(s) at any time without prior notice.

### READ THIS MANUAL THOROUGHLY

If any portion of this manual is not understood, contact the nearest Authorized Service Dealer for starting, operating and servicing procedures.

Throughout this publication, and on tags and decals affixed to the generator, DANGER, WARNING, CAUTION and NOTE blocks are used to alert personnel to special instructions about a particular service or operation that may be hazardous if performed incorrectly or carelessly. Observe them carefully. Their definitions are as follows:

#### **▲ DANGER!**

**INDICATES A HAZARDOUS SITUATION OR ACTION WHICH, IF NOT AVOIDED, WILL RESULT IN DEATH OR SERIOUS INJURY.**

#### **▲ WARNING!**

**Indicates a hazardous situation or action which, if not avoided, could result in death or serious injury.**

#### **▲ CAUTION!**

**Indicates a hazardous situation or action which, if not avoided, could result in minor or moderate injury.**

#### **NOTE:**

**Notes contain additional information important to a procedure and will be found within the regular text body of this manual.**

These safety warnings cannot eliminate the hazards that they indicate. Common sense and strict compliance with the special instructions while performing the action or service are essential to preventing accidents.

Four commonly used safety symbols accompany the **DANGER**, **WARNING** and **CAUTION** blocks. The type of information each indicates is as follows:

 This symbol points out important safety information that, if not followed, could endanger personal safety and/or property of others.

 This symbol points out potential explosion hazard.

 This symbol points out potential fire hazard.

 This symbol points out potential electrical shock hazard.

The operator is responsible for proper and safe use of the equipment. The manufacturer strongly recommends that the operator read this Owner's Manual and thoroughly understand all instructions before using this equipment. The manufacturer also strongly recommends instructing other users to properly start and operate the unit. This prepares them if they need to operate the equipment in an emergency.

### OPERATION AND MAINTENANCE

It is the operator's responsibility to perform all safety checks, to make sure that all maintenance for safe operation is performed promptly, and to have the equipment checked periodically by an Authorized Service Dealer. Normal maintenance service and replacement of parts are the responsibility of the owner/operator and, as such, are not considered defects in materials or workmanship within the terms of the warranty. Individual operating habits and usage contribute to the need for maintenance service.

Proper maintenance and care of the generator ensure a minimum number of problems and keep operating expenses at a minimum. See an Authorized Service Dealer for service aids and accessories.

Operating instructions presented in this manual assume that the stationary emergency electric system has been installed by an Authorized Service Dealer or other competent, qualified contractor. Installation of this equipment is not a "do-it-yourself" project.

### HOW TO OBTAIN SERVICE

When the generator requires servicing or repairs, contact an Authorized Service Dealer for assistance. Service technicians are factory-trained and are capable of handling all service needs.

When contacting an Authorized Service Dealer about parts and service, always supply the complete model number of the unit as given on the front cover of this manual or on the DATA LABEL affixed to the unit.

## **AUTHORIZED SERVICE DEALER LOCATION**

To locate the nearest AUTHORIZED SERVICE  
DEALER, please call this number:

**1-800-333-1322**

DEALER LOCATION INFORMATION  
CAN BE OBTAINED AT THIS NUMBER  
or visit the website at

**[www.generac.com](http://www.generac.com)**

## Safety Rules

**! SAVE THESE INSTRUCTIONS – The manufacturer suggests that these rules for safe operation be copied and posted in potential hazard areas. Safety should be stressed to all operators, potential operators, and service and repair technicians for this equipment.**

**! SAVE THESE INSTRUCTIONS – This manual contains important instructions that should be followed during installation and maintenance of the generator and batteries.**

Study these SAFETY RULES carefully before installing, operating or servicing this equipment. Become familiar with this *Owner's Manual* and with the unit. The generator can operate safely, efficiently and reliably only if it is properly installed, operated and maintained. Many accidents are caused by failing to follow simple and fundamental rules or precautions.

The manufacturer cannot anticipate every possible circumstance that might involve a hazard. The warnings in this manual, and on tags and decals affixed to the unit are, therefore, not all-inclusive. If using a procedure, work method or operating technique that the manufacturer does not specifically recommend, ensure that it is safe for others. Also make sure the procedure, work method or operating technique utilized does not render the generator unsafe.

### **! DANGER!**

**! Despite the safe design of this generator, operating this equipment imprudently, neglecting its maintenance or being careless can cause possible injury or death. Permit only responsible and capable persons to install, operate or maintain this equipment.**

**! Potentially lethal voltages are generated by these machines. Ensure all steps are taken to render the machine safe before attempting to work on the generator.**

**! Parts of the generator are rotating and/or hot during operation. Exercise care near running generators.**

### **GENERAL HAZARDS**

- For safety reasons, the manufacturer recommends that this equipment be installed, serviced and repaired by an Authorized Service Dealer or other competent, qualified electrician or installation technician who is familiar with applicable codes, standards and regulations. The operator also must comply with all such codes, standards and regulations.
- Installation, operation, servicing and repair of this (and related) equipment must always comply with applicable codes, standards, laws and regulations. Adhere strictly to local, state and national electrical and building codes. Comply with regulations the Occupational Safety and Health Administration (OSHA) has established. Also, ensure that the generator is installed, operated and serviced in accordance with the manufacturer's instructions and recommendations. Following installation, do nothing that might render the unit unsafe or in noncompliance with the aforementioned codes, standards, laws and regulations.

- **The engine exhaust fumes contain carbon monoxide gas, which can be DEADLY.** This dangerous gas, if breathed in sufficient concentrations, can cause unconsciousness or even death. For that reason, adequate ventilation must be provided. Exhaust gases must be piped safely away from any building or enclosure that houses the generator to an area where people, animals, etc., will not be harmed. This exhaust system must be installed properly, in strict compliance with applicable codes and standards.
- Keep hands, feet, clothing, etc., away from drive belts, fans, and other moving or hot parts. Never remove any drive belt or fan guard while the unit is operating.
- Adequate, unobstructed flow of cooling and ventilating air is critical in any room or building housing the generator to prevent buildup of explosive gases and to ensure correct generator operation. Do not alter the installation or permit even partial blockage of ventilation provisions, as this can seriously affect safe operation of the generator.
- Keep the area around the generator clean and uncluttered. Remove any materials that could become hazardous.
- When working on this equipment, remain alert at all times. Never work on the equipment when physically or mentally fatigued.
- Inspect the generator regularly, and promptly repair or replace all worn, damaged or defective parts using only factory-approved parts.
- Before performing any maintenance on the generator, disconnect its battery cables to prevent accidental start-up. Disconnect the cable from the battery post indicated by a NEGATIVE, NEG or (-) first. Reconnect that cable last.
- Never use the generator or any of its parts as a step. Stepping on the unit can stress and break parts, and may result in dangerous operating conditions from leaking exhaust gases, fuel leakage, oil leakage, etc.

## ELECTRICAL HAZARDS

- All generators covered by this manual produce dangerous electrical voltages and can cause fatal electrical shock. Utility power delivers extremely high and dangerous voltages to the transfer switch as well as the stationary emergency generator. Avoid contact with bare wires, terminals, connections, etc., on the generator as well as the transfer switch, if applicable. Ensure all appropriate covers, guards and barriers are in place before operating the generator. If work must be done around an operating unit, stand on an insulated, dry surface to reduce shock hazard.
- Do not handle any kind of electrical device while standing in water, while barefoot, or while hands or feet are wet. **DANGEROUS ELECTRICAL SHOCK MAY RESULT.**
- If people must stand on metal or concrete while installing, operating, servicing, adjusting or repairing this equipment, place insulative mats over a dry wooden platform. Work on the equipment only while standing on such insulative mats.
- The generator set must be grounded in accordance with the *National Electrical Code* and any state or local requirements.
- Wire gauge sizes of electrical wiring, cables and cord sets must be adequate to handle the maximum electrical current (ampacity) to which they will be subjected. See the Field Wiring Requirements Table.
- Before installing or servicing this (and related) equipment, make sure that all power voltage supplies are positively turned off at their source. Failure to do so will result in hazardous and possibly fatal electrical shock.
- Connecting this unit to an electrical system normally supplied by an electric utility shall be by means of a transfer switch so as to isolate the generator electric system from the electric utility distribution system when the generator is operating. Failure to isolate the two electric system power sources from each other by such means will result in damage to the generator and may also result in injury or death to utility power workers due to backfeed of electrical energy.
- Generators installed with an automatic transfer switch will crank and start automatically when NORMAL (UTILITY) source voltage is removed or is below an acceptable preset level. To prevent such automatic start-up and possible injury to personnel, disable the generator's automatic start circuit (battery cables, etc.) before working on or around the unit. Then, place a "Do Not Operate" tag on the generator control panel and on the transfer switch.
- In case of accident caused by electric shock, immediately shut down the source of electrical power. If this is not possible, attempt to free the victim from the live conductor. **AVOID DIRECT CONTACT WITH THE VICTIM.** Use a nonconducting implement, such as a dry rope or board, to free the victim from the live conductor. If the victim is unconscious, apply first aid and get immediate medical help.
- Never wear jewelry when working on this equipment. Jewelry can conduct electricity resulting in electric shock, or may get caught in moving components causing injury.

## FIRE HAZARDS

- Keep a fire extinguisher near the generator at all times. Do NOT use any carbon tetra-chloride type extinguisher. Its fumes are toxic, and the liquid can deteriorate wiring insulation. Keep the extinguisher properly charged and be familiar with its use. If there are any questions pertaining to fire extinguishers, consult the local fire department.

## EXPLOSION HAZARDS

- Properly ventilate any room or building housing the generator to prevent build-up of explosive gas.
- Do not smoke around the generator. Wipe up any fuel or oil spills immediately. Ensure that no combustible materials are left in the generator compartment, or on or near the generator, as FIRE or EXPLOSION may result. Keep the area surrounding the generator clean and free from debris.
- All fuel types are potentially FLAMMABLE and/or EXPLOSIVE and should be handled with care. Comply with all laws regulating the storage and handling of fuels. Inspect the unit's fuel system frequently and correct any leaks immediately. Fuel supply lines must be properly installed, purged and leak tested according to applicable fuel-gas codes before placing this equipment into service.
- Diesel fuels are highly FLAMMABLE.

### **CALIFORNIA PROPOSITION 65 WARNING**

Engine exhaust and some of its constituents are known to the State of California to cause cancer, birth defects and other reproductive harm.

### **CALIFORNIA PROPOSITION 65 WARNING**

This product contains or emits chemicals known to the State of California to cause cancer, birth defects and other reproductive harm.

# General Information

## IDENTIFICATION RECORD

### DATA LABEL

Every generator set has a DATA LABEL that contains important information pertinent to the generator (Figure 1.1). The data label, which can be found attached to the generator's lower connection box, lists the unit's serial number and its rated voltage, amps, wattage capacity, phase, frequency, rpm, power factor, etc.

Figure 1.1 — Data Label

MODEL		SERIAL	
TYPE CODE	ENGINE NO		
RATED KW	RATED KVA	UPSIZING ALT. KW	
VOLTS	AMPS / /		
PHASE	POWER FACTOR	HERTZ	
BRKR KW	BRKR AMPS	X'd	X'd
ALT. R.P.M.	ENG. R.P.M.	PROD. DATE	
CLASS <input type="checkbox"/> ROTOR <input type="checkbox"/> STATOR WINDING INSULATION AT 40° AMBIENT			

454583 REV. B

**NOTE:**

The above is a generic representation of a data label. For actual information related to this particular model, please refer to the "construction document" located at the end of this manual, or to the data labels affixed to the unit.

### GENERATOR SET XPL LABEL

Every generator set has a XPL LABEL affixed to the lower connection box (Figure 1.2). Additionally, a printed CONSTRUCTION DOCUMENT containing identical information can be found at the end of this manual.

When requesting information, ordering replacement parts, asking for service, etc., one or more of the following may be needed:

- Generator Model Number
- Date of Manufacture
- Generator Identification Code
- Generator Assembly Groups

#### Generator Model Number

This number is the key to numerous engineering and manufacturing details pertaining to the unit. Always supply this number when requesting service, ordering parts or seeking information.

Figure 1.2 — XPL Label

GENERAC POWER SYSTEMS			
MODEL NO. 00A 00000 S		DATE 00/00/06 (Generator ID Code)	
GROUP	DESCRIPTION	ASSEMBLY NUMBERS	
A	Generator	00000	00000
B	Control Panel	00000	00000 00000
C	Mounting Base	00000	00000 00000
D	Engine & Accy.	00000	00000
E	Fuel Systems	00000	
F	Compartments	00000	00000
G	Wiring Diagrams	00000	00000 00000
H	Kits	00000	00000
WHEN ORDERING REPAIR PARTS, ALWAYS GIVE THE ABOVE INFORMATION			

**NOTE:**

The above is a generic representation of an XPL label. For actual information related to this particular model, please refer to the "construction document" located at the end of this manual, or to the data cards affixed to the unit.

#### Identification Code

Use this code to obtain important information about the generator. For example, if the code is ...

**SD 0100 A G17 4.5 D 18 H B Y Y 3**

– identify the generator as follows:

- SD – Stationary emergency diesel generator ("SG" indicates a stationary emergency gaseous fuel unit).
- 0100 – Rated output is 100,000 watts (100 kW).
- A – Voltage code (see "Voltage Codes").
- G17 – Indicates engine MFG (for Generac use).
- 4.5 – Engine is 4.5 liter.
- D – Unit has diesel fuel system ("N" indicates natural gas; "L" indicates LP Liquid Withdrawal; "V" indicates LP Vapor Withdrawal).
- 18 – Alternator rpm rating (1,800 rpm); "36" indicates 3,600 rpm.
- H – Unit has an option "H" control panel ("G" panels are also available on some units).
- B – Indicates a brushless unit ("P" indicates a permanent magnet excitation).
- Y – Unit is equipped with a standard enclosure ("N" indicates no enclosure; "S" indicates Level 1 sound attenuation; "L" indicates Level 2 sound attenuation).
- "Y" indicates a muffler has been mounted; N – Unit does not have an exhaust muffler; "L" indicates a muffler has been shipped loose with the unit).
- 3 – Emission designation (for factory use).

### Groups and Assembly Numbers

The XPL label lists the groups and corresponding assembly numbers for each unit. The assembly numbers refer to exploded view drawing numbers that are applicable to the specific generator model. These drawings are located in the back half of this manual.

### Voltage Codes

The identification code letter following the unit's kilowatt rating is the generator's "voltage code." Any one of the following voltage codes may be listed.

A	-	120/240 volts, single-phase, four-lead, 60 Hz
D	-	120/240 volts, single- and three-phase, 12-lead, 60 Hz
G	-	120/208 volts, three-phase, 12-lead, 60 Hz Broad Range
J	-	120/240 volts, three-phase, 12-lead, 60 Hz Broad Range
K	-	277/480 volts, three-phase, 12-lead, 60 Hz Broad Range
L	-	346/600 volts, three-phase, six-lead, 60 Hz
M	-	110/220 volts, single-phase, four-lead, 50 Hz
N	-	115/200 volts, three-phase, 12-lead, 50 Hz Broad Range
P	-	100/200 volts, three-phase, 12-lead, 50 Hz Broad Range
R	-	231/400 volts, three-phase, 12-lead, 50 Hz Broad Range
S	-	277/480 volts, three-phase, six-lead, 50 Hz

### EQUIPMENT DESCRIPTION

This equipment is a revolving field, alternating current generator set. The generator was designed to supply electrical power for the operation of compatible electrical loads when the UTILITY power supply is not available or has dropped to an unacceptable level.

The generator's revolving field is directly connected to and driven by an engine by means of flexible discs. Generators with a four-pole rotor are driven at rated speeds of 1,800 rpm to supply a frequency of 60 Hertz.

Refer to the data label on this specific generator or to the data label affixed to the unit for rated AC voltage, wattage, amperage, number of phases, etc. See "Identification Code" for an explanation of the way to identify the unit's features.

### STANDARD GENERATOR FEATURES

This generator incorporates the following generator features:

- The rotor insulation system is Class "H" rated, and the stator insulation is Class "H" rated as defined by NEMA MG1-22.4 and NEMA MG1-1.65.
- The generator is self-ventilated and drip-proof constructed.
- The voltage waveform deviation, total harmonic content of the AC waveform and "telephone influence factor" have been evaluated and are acceptable according to NEMA MG1-22.
- All prototype tested models have passed three-phase symmetrical short circuit test to ensure system protection and reliability.

### ENGINE PROTECTIVE DEVICES

The stationary emergency generator may be required to operate for long periods of time without an operator on hand to monitor such engine conditions as coolant temperature, oil pressure or rpm. For that reason, the engine has several devices designed to protect it against potentially damaging conditions by automatically shutting down the unit when the oil pressure is too low, the coolant temperature is too high, the coolant level is too low, or the engine is running too fast.

#### NOTE:

**Engine protective switches and sensors are mentioned here for the reader's convenience. Also refer to the applicable control panel manual for additional automatic engine shutdown information.**

#### COOLANT TEMPERATURE SENDER

This sender automatically shuts down the engine if the engine coolant temperature rises above a safe level.

#### LOW COOLANT LEVEL SENSOR

Should the engine coolant level drop below the level of the high coolant temperature switch, it is possible for the engine to overheat without automatic shutdown. To prevent such overheating, the engine has a low coolant level sensor. If the level of engine coolant drops below the level of the low coolant level sensor, the engine automatically shuts down.

#### OIL PRESSURE SENDER

This sender monitors oil pressure in the engine. If oil pressure drops below a safe level, the control system automatically shuts down the engine.

#### OVERSPEED SHUTDOWN

A speed circuit controls engine cranking, start-up, operation and shutdown. Engine speed signals are delivered to the circuit board whenever the unit is running. Should the engine overspeed above a safe, preset value, the circuit board initiates an automatic engine shutdown.

#### OVERCRANK SHUTDOWN

After a prespecified duration of cranking, this function ends the cranking if the engine has failed to start.

#### RPM SENSOR LOSS SHUTDOWN

If the speed signal to the control panel is lost, engine shutdown will occur.

### DC FUSES

These fuses are located inside the front panel of the control system. They protect the panel wiring and components from damaging overload.

# General Information

## FUEL SYSTEM

### DIESEL FUEL SYSTEM

Diesel fuel is supplied to the generator set from a base-mounted fuel tank or external source.

Diesel fuels are less volatile than gaseous fuels, however, careless installation can lead to safety hazards and/or serious problems with engine/generator performance and reliability.

#### NOTE:

Appropriate care should be taken in applications where extremely low ambient temperatures are possible to ensure the temperature of the diesel fuel is not allowed to fall below levels where "gelling" could occur.

## SPECIFICATIONS

### GENERATOR

Refer to the data plate on the generator for rated watts, amperes, frequency, voltage, phase and other pertinent information. Refer to the drawings in the back of this manual for engine, cooling system, and exhaust system specifications.

### ENGINE OIL RECOMMENDATIONS

The unit has been filled with 15W-40 engine oil at the factory. Use a high-quality detergent oil classified "For Service SJ and CG/CH". Detergent oils keep the engine cleaner and reduce carbon deposits. Use oil having the following SAE viscosity rating, based on the ambient temperature range anticipated before the next oil change (Figure 1.3).

## COOLANT

Use only de-ionized water and Ethylene glycol antifreeze (Propylene glycol can also be used but should not be mixed with Ethylene glycol - see DANGER below). When adding coolant, always add the recommended 50-50 mixture.

### ⚠ DANGER!

⚠ Do not remove the radiator pressure cap while the engine is hot or serious burns from boiling liquid or steam could result.

⚠ Ethylene glycol base antifreeze is poisonous. Do not use mouth to siphon coolant from the radiator, recovery bottle or any container. Wash hands thoroughly after handling. Never store used antifreeze in an open container because animals are attracted to the smell and taste of antifreeze even though it is poisonous to them.

### ⚠ CAUTION!

⚠ Do not use any chromate base rust inhibitor with propylene glycol base antifreeze. Using any high silicate antifreeze boosters or additives also will cause overheating. We also recommend that any soluble oil inhibitor is NOT USED for this equipment.

### GEARBOX LUBRICATION

If the generator set is equipped with a gearbox, the appropriate lubricant is SAE 90 gear oil.

Figure 1.3 – Engine Oil Recommendations

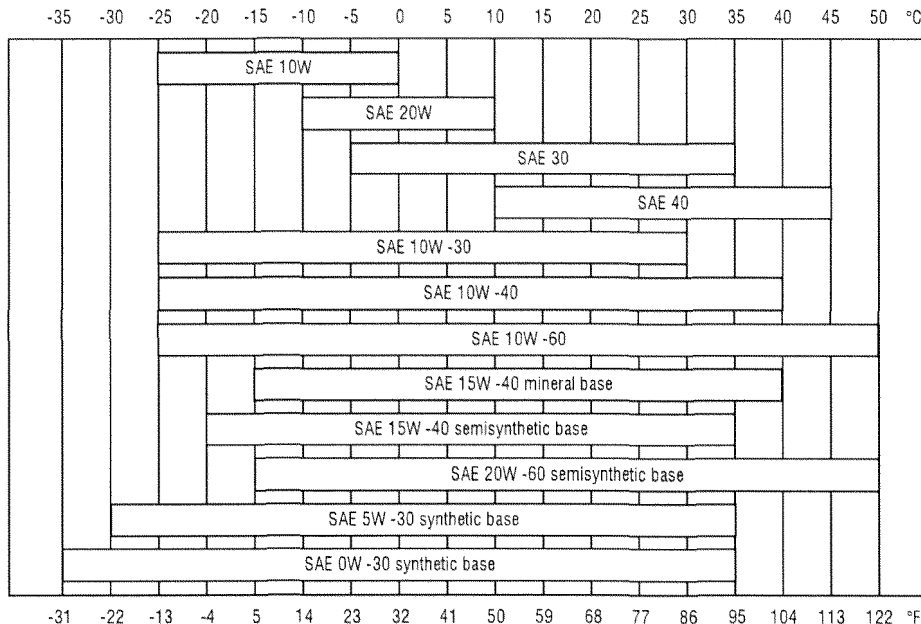



## FUEL SYSTEM REQUIREMENTS AND RECOMMENDATIONS

**Diesel Fuel System:** See Chapter 8 of Engine-Generator Stationary Emergency Electric Power Systems Installer's Guide and Reference Manual (part no. 046622).

1. Beginning **October 1, 2007**, owners and operators that use diesel fuel must use diesel fuel that meets:
  - A. Sulfur content of 500 parts per million (ppm) maximum.
  - B. Cetane index or aromatic content as follows:
    - A minimum cetane index of 40 or;
    - A maximum aromatic content of 35 volume percent.
2. Beginning **October 1, 2010**, owners and operators that use diesel fuel must use diesel fuel that meets:
  - A. Sulfur content of 15 parts per million (ppm) maximum.
  - B. Cetane index or aromatic content as follows:
    - A minimum cetane index of 40 or;
    - A maximum aromatic content of 35 volume percent.

## BATTERY INSTALLATION

When a unit is supplied with out a battery or during replacement use the following table to properly select the battery size and minimum Cold Cranking Ampere required for a particular unit.

Diesel Engine	Battery Size	Minimum CCA
2.4L	GRP 27 or GRP 31	650 or 925
3.4L		
4.5L	GRP 31 or GRP 31E	925
6.7L (100, 130Kw)	1 or 2 X GRP 31	925
6.7L (150, 175Kw)	2 X GRP 31	925
8.7L		
10.3L	2 x GRP 31 or 2 x GRP 8D	925 or 1155
12.9L		
13.0L		
16.0L		
18.0L		
22.0L		

Fill the battery with the proper electrolyte fluid if necessary and have the battery fully charged before installing it.

Before installing and connecting the battery, complete the following steps:

1. Set the generator's AUTO/OFF/MANUAL switch to OFF.
2. Turn off utility power supply to the transfer switch.
3. Remove the 10A and 15A fuses from the generator control panel.

Battery cables were factory connected at the generator (Figure 1.4). Connect cables to battery posts as follows:

**Figure 1.4 – Battery Cable Connections**

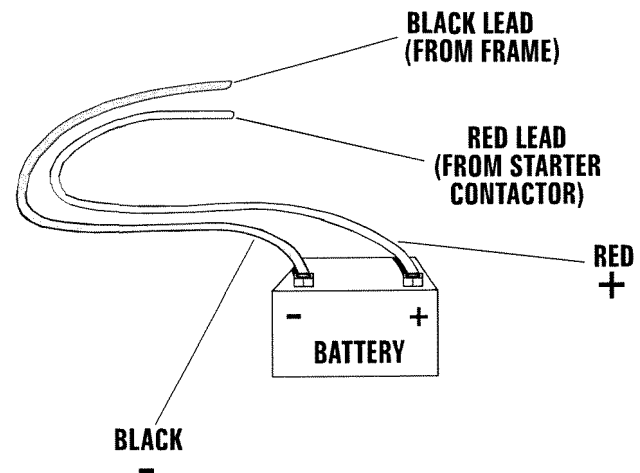

4. Connect the red battery cable (from starter contactor) to the battery post indicated by a positive, POS or (+).
5. Connect the black battery cable (from frame ground) to the battery post indicated by a negative, NEG or (—).

**NOTE:**

**Damage will result if battery connections are made in reverse.**

**NOTE:**

The generator is equipped with a battery trickle charger that is active when the unit is set up for automatic operation. With the battery installed and utility power source voltage available, the battery receives a trickle charge while the engine is not running, to prevent self-discharge. The trickle charger is designed to help extend the life of the battery by maintaining the battery when the unit is not running. The trickle charge feature cannot be used to recharge a discharged battery.

## General Information

### THE BATTERY

#### ⚠ DANGER!

- ⚠ Do not dispose of the battery in a fire. The battery is capable of exploding.
- ⚠ A battery presents a risk of electrical shock and high short circuit current. The following precautions are to be observed when working on batteries:
  - Remove the 10A and 15A fuses from the generator control panel.
  - Remove watches, rings or other metal objects;
  - Use tools with insulated handles;
  - Wear rubber gloves and boots;
  - Do not lay tools or metal parts on top of the battery; and
  - Disconnect charging source prior to connecting or disconnecting battery terminals.

#### ⚠ WARNING!

- ⚠ Do not open or mutilate the battery. Released electrolyte has been known to be harmful to the skin and eyes, and to be toxic.
- ⚠ The electrolyte is a dilute sulfuric acid that is harmful to the skin and eyes. It is electrically conductive and corrosive.

The following procedures are to be observed:

- Wear full eye protection and protective clothing;
- Where electrolyte contacts the skin, wash it off immediately with water;
- Where electrolyte contacts the eyes, flush thoroughly and immediately with water and seek medical attention; and
- Spilled electrolyte is to be washed down with an acid neutralizing agent. A common practice is to use a solution of 1 pound (500 grams) bicarbonate of soda to 1 gallon (4 liters) of water. The bicarbonate of soda solution is to be added until the evidence of reaction (foaming) has ceased. The resulting liquid is to be flushed with water and the area dried.

⚠ Lead-acid batteries present a risk of fire because they generate hydrogen gas. The following procedures are to be followed:

- DO NOT SMOKE when near the battery;
- DO NOT cause flame or spark in battery area; and
- Discharge static electricity from body before touching the battery by first touching a grounded metal surface.

- ⚠ Be sure the AUTO/OFF/MANUAL switch is set to the OFF position before connecting the battery cables. If the switch is set to AUTO or MANUAL, the generator can crank and start as soon as the battery cables are connected.

- ⚠ Be sure the utility power supply is turned off and the 10A and 15A fuses are removed from the generator control panel, or sparking may occur at the battery posts as the cables are attached and cause an explosion.

Servicing of the battery is to be performed or supervised by personnel knowledgeable of batteries and the required precautions. Keep unauthorized personnel away from batteries.

A negative ground system is used. Battery connections are shown on the wiring diagrams. Make sure the battery is correctly connected and terminals are tight. Observe battery polarity when connecting the battery to the generator set.

### GENERATOR AC LEAD CONNECTIONS

See "Voltage Codes". This generator may be rated at any one of several voltages, either single-phase or three-phase. The electrical wires in the unit's AC connection (lower) panel should be installed according to the number of leads and the voltage/phase required for the application. If there is any question regarding lead connection, refer to Figures 1.4 through 1.9.

Voltage codes apply to the type of stator assembly installed on a particular generator.

#### FOUR-LEAD, SINGLE-PHASE STATOR

Four-lead generators are dual voltage coils or windings (Figure 1.5). Units may be assigned any of the following voltage codes:

- "A" units are rated 120/240 VAC, single-phase, 60 Hertz.
- "M" units are rated 110/220 VAC, single-phase, 50 Hertz.

Each stator winding in this case delivers a 110 VAC or 120 VAC output; connecting the two windings series results in a 220 VAC or 240 VAC output.

The neutral line is formed by a junction of stator leads 22 and 33. Therefore, connection of 120 VAC (60 Hertz) or 110 VAC (50 Hertz) loads across leads 11 and neutral, or across leads 44 and neutral can be made.

Figure 1.5 – Four-lead, Single-phase Stator

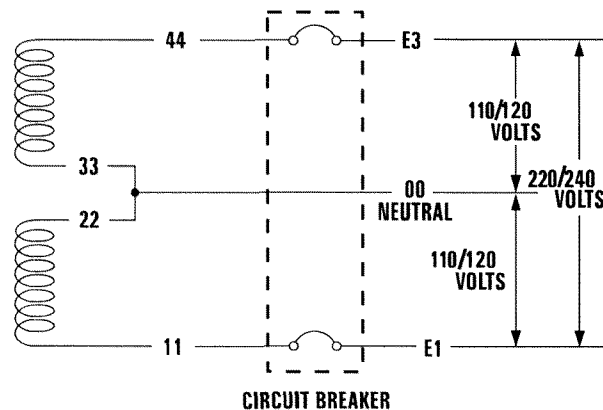

# General Information

**Figure 1.9 – Single-/Three-phase Delta Stator Connection**

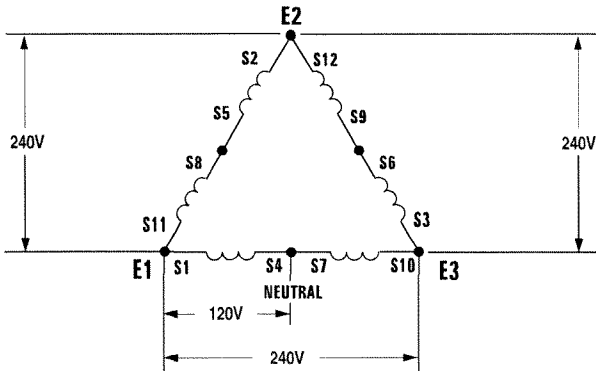

**Figure 1.10 – Six-lead Stator Connection**

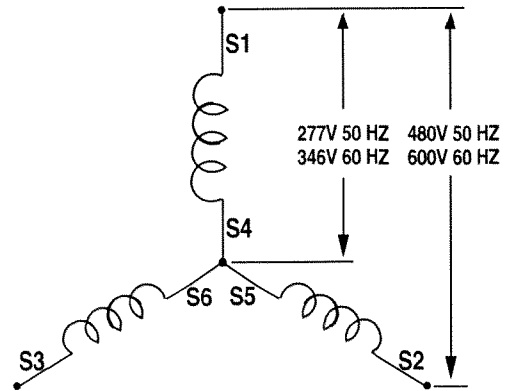

## SIX-LEAD, 600 VAC, THREE-PHASE STATOR

This type of stator has three coils and six leads (Figure 1.10). Units may be assigned any of the following voltage codes:

- “L” units are rated 346/600 VAC, three-phase, 60 Hertz.
- “S” units are rated 277/480 VAC, three-phase, 50 Hertz.

## FIELD WIRING CONNECTIONS REQUIREMENTS

The table should be used as a reference for: wire type, temperature rating, and size range of output wires to be connected to the circuit breakers. Wire sizes should be in accordance with table 310.16 of the National Electric Code (NEC).

### FIELD WIRING REQUIREMENTS TABLE

Breaker Frame	Circuit Breaker Range (A)	Wire Type	Wire Temperature Rating	Circuit Breaker Lug AWG Wire Range / (Number of Conductors)	Torque to Wire
Series G - JG Frame	20 - 250	Cu	75°C	4-350 kcmil (1)	180 in-lb
Series G - LG Frame	160 - 600	Cu/Al	75°C	2-500 kcmil (2)	375 in-lb
Series C - F Frame	15 - 100	Cu/Al	75°C	14-1/0 (1)	(#14-10) 35 in-lb
					(#8) 40 in-lb
					(#6-4) 45 in-lb
	60 - 200	Cu/Al	75°C	4-4/0 (1)	120 in-lb
	100 - 225	Cu/Al	75°C	6-300 kcmil (1)	120 in-lb
Series C - J Frame	250	Cu	75°C	4-350 kcmil (1)	275 in-lb
Series C - K Frame	225	Cu/Al	75°C	3-350 kcmil (1)	275 in-lb
	300	Cu/Al	75°C	250-500 kcmil (1)	375 in-lb
	350 - 400	Cu/Al	75°C	3/0-250 kcmil (2)	275 in-lb
Series C - L Frame	450 - 500	Cu/Al	75°C	3/0-350 kcmil (2)	275 in-lb
	600	Cu/Al	75°C	400-550 kcmil (2)	275 in-lb
Series C - M Frame	700 - 800	Cu/Al	75°C	3/0-400 kcmil (3)	375 in-lb
Series C - N Frame	900 - 1000	Cu/Al	75°C	4/0-500 kcmil (4)	375 in-lb
	1200	Cu/Al	75°C	500-750 kcmil (3)	450 in-lb
Series C - R Frame	1400 - 1600	Cu/Al	75°C	500-1000 kcmil (4)	550 in-lb

**NOTE:** All field installations must meet the National Electric Code for wire size and bending space requirements.

## FIELD WIRING CONNECTIONS TO BUSS BARS

500Kw Volvo and 500/600Kw Doosan powered units supplied with Series C - R Frame Breakers rated 1400, 1600, 2000 and 2500A have Buss Bars supplied in the connection Module for the connection of the Field Conductors. The following information should be followed in order to obtain a suitable electrical connection to the Buss Bars.

- **Conductor Lugs** - The Buss Bars have been configured to accept Aluminum Compression Lugs suitable for copper or aluminum stranded wire.
- **Suggested Manufacturer** - PENN UNION CORP
- **Manufacturers Part No.** - BLUA060D2
- **Type** - Dual Rated (AL/CU), Two 1/2" Studs spaced 1 3/4" Apart
- **Wire Size** - 600 kcmil

### Required Hardware

Below is the recommended hardware required to attach the Lugs to the Buss Bars.

- M12 x 65mm Grade 8.8 Hex Head Cap Screw, M12 Flat Washers, Lock Washer and Nut

or

- 1/2"-20 x 2.5" Grade SAE 5 Hex Head Cap Screw, 1/2" Flat Washers, Lock Washer and Nut

**Required Torque** - Tighten fasteners to:

M12	-	Dry 75 Ft-Lbs	-	Lubed 58 Ft-Lbs
1/2"	-	Dry 85 Ft-Lbs	-	Lubed 65 Ft-Lbs

## GENERATOR AND LOAD COMPATIBILITY

The generator must be fully compatible with the rated voltage, phase and frequency of the connected electrical loads. The generator, connected electrical devices, or both, can be damaged if voltage, phase and frequency are not compatible.

### NOTE:

**This manual assumes that the stationary emergency generator has been properly selected, installed and interconnected by a competent, qualified electrician or installation contractor. Once the installation is complete, do nothing that may result in non-compatibility between the generator and connected electrical loads.**

## STARTING AIDS

The stationary emergency generator may be equipped with one or more starting aids that serve to provide quicker, easier starts under varying climactic conditions.

This generator may have been mounted with (a) an engine coolant heater, (b) an engine oil heater, (c) a battery warmer or (d) a battery charger. These aids are powered by a normal (utility) power source during nonoperating periods.

## ENGINE COOLANT HEATERS

If the unit is equipped with an engine coolant (block) heater (Figure 1.11), it is powered by a circuit normally fed by the utility power supply. This heats the engine coolant when the unit is not operating. This action keeps the engine warm even in cold weather, helping to ensure quicker starts. Heated coolant in the engine rises continuously drawing cold coolant into the heater, creating a constant flow of warm coolant through the engine.

**Figure 1.11 – Typical Engine Coolant Heaters**

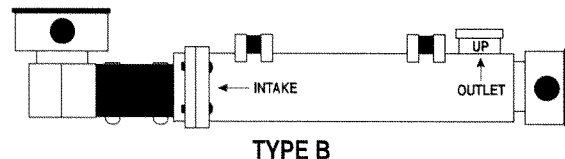
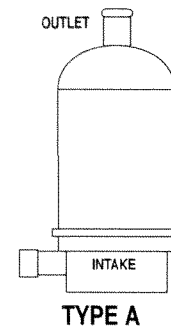

## ENGINE OIL HEATER (OPTIONAL)

The engine oil heater is designed for installations where the engine oil must be kept near operating temperature at all times. If included with this unit, a low-watt density heater and thermostat are mounted in the engine's oil sump or on the sump pan (Figure 1.12). The heater and thermostat do not require maintenance.

1. Disconnect battery cables to prevent accidental start-up. Disconnect the negative battery cable first from the battery post indicated by (-) or NEG.
2. Make sure power is off from the appropriate power source.
3. To connect the wires, hold the bare metal leads together and place a wire nut over them, then twist clockwise until tight. For all these connections, use the wire nuts provided.
4. Connect the ground wire from 120V power source to the ground wire from oil heater.
5. Using wire nuts provided connect the white wire and black wire from the oil heater as follows:
  - The white (common) power wire from 120V power source to 1st wire from the oil heater.
  - The wire from load side of thermostat to 2nd wire from the oil heater.

## FIELD WIRING CONNECTIONS TO BUSS BARS

Units supplied with Series C - R Frame Breakers rated 1600, 2000 and 2500A have Buss Bars supplied in the connection Module for the connection of the Field Conductors. The following information should be followed in order to obtain a suitable electrical connection to the Buss Bars.

- **Conductor Lugs** - The Buss Bars have been configured to accept Aluminum Compression Lugs suitable for copper or aluminum stranded wire.
- **Suggested Manufacturer** - PENN UNION CORP
- **Manufacturers Part No.** - BLUA060D2
- **Type** - Dual Rated (AL/CU), Two 1/2" Studs spaced 1 3/4" Apart
- **Wire Size** - 600 kcmil

## Required Hardware

Below is the recommended hardware required to attach the Lugs to the Buss Bars.

- M12 x 65mm Grade 8.8 Hex Head Cap Screw, M12 Flat Washers, Lock Washer and Nut

or

- 1/2"-20 x 2.5" Grade SAE 5 Hex Head Cap Screw, 1/2" Flat Washers, Lock Washer and Nut

**Required Torque** - Tighten fasteners to:

M12	-	Dry 75 Ft-Lbs	-	Lubed 58 Ft-Lbs
1/2"	-	Dry 85 Ft-Lbs	-	Lubed 65 Ft-Lbs

## GENERATOR AND LOAD COMPATIBILITY

The generator must be fully compatible with the rated voltage, phase and frequency of the connected electrical loads. The generator, connected electrical devices, or both, can be damaged if voltage, phase and frequency are not compatible.

### NOTE:

**This manual assumes that the stationary emergency generator has been properly selected, installed and interconnected by a competent, qualified electrician or installation contractor. Once the installation is complete, do nothing that may result in non-compatibility between the generator and connected electrical loads.**

## STARTING AIDS

The stationary emergency generator may be equipped with one or more starting aids that serve to provide quicker, easier starts under varying climactic conditions.

This generator may have been mounted with (a) an engine coolant heater, (b) an engine oil heater, (c) a battery warmer or (d) a battery charger. These aids are powered by a normal (utility) power source during nonoperating periods.

## ENGINE COOLANT HEATERS

If the unit is equipped with an engine coolant (block) heater (Figure 1.11), it is powered by a circuit normally fed by the utility power supply. This heats the engine coolant when the unit is not operating. This action keeps the engine warm even in cold weather, helping to ensure quicker starts. Heated coolant in the engine rises continuously drawing cold coolant into the heater, creating a constant flow of warm coolant through the engine.

**Figure 1.11 – Typical Engine Coolant Heaters**

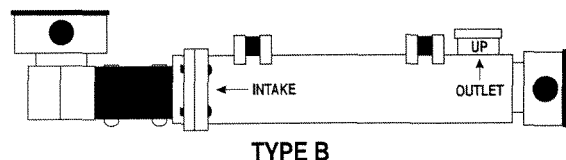
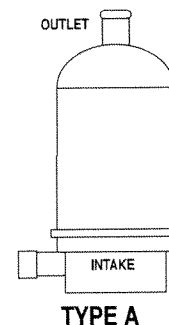

## ENGINE OIL HEATER (OPTIONAL)

The engine oil heater is designed for installations where the engine oil must be kept near operating temperature at all times. If included with this unit, a low-watt density heater and thermostat are mounted in the engine's oil sump or on the sump pan (Figure 1.12). The heater and thermostat do not require maintenance.

1. Disconnect battery cables to prevent accidental start-up. Disconnect the negative battery cable first from the battery post indicated by (-) or NEG.
2. Make sure power is off from the appropriate power source.
3. To connect the wires, hold the bare metal leads together and place a wire nut over them, then twist clockwise until tight. For all these connections, use the wire nuts provided.
4. Connect the ground wire from 120V power source to the ground wire from oil heater.
5. Using wire nuts provided connect the white wire and black wire from the oil heater as follows:
  - The white (common) power wire from 120V power source to 1st wire from the oil heater.
  - The wire from load side of thermostat to 2nd wire from the oil heater.

## General Information

### ▲ CAUTION!

▲ **Be sure no bare wire or wire strands are visible after making connections.**

6. Push all wires and wire nuts into junction box.
7. Assemble junction box cover to junction box.
8. Reconnect battery cables to battery posts. Connect the positive cable first to the battery post indicated by (+) or POS.

*Figure 1.12 – Oil Heater Kit*

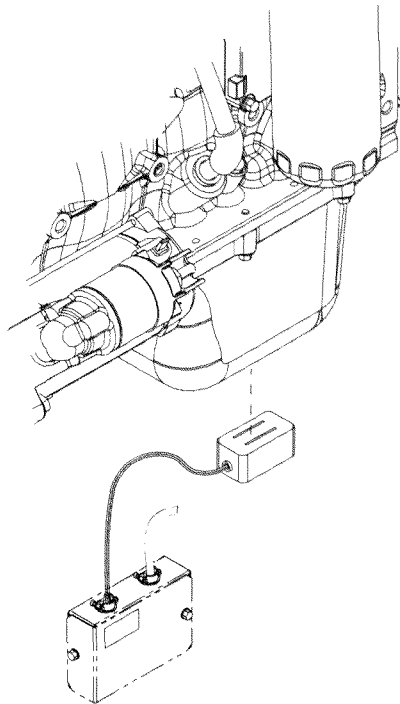

### BATTERY WARMERS (OPTIONAL)

When used in conjunction with a coolant (block) heater, battery warmers (Figure 1.13) aid in ensuring that the engine will reach maximum cranking speed.

1. Disconnect battery cables to prevent accidental start-up. Disconnect the negative battery cable first from the battery post indicated by (-) or NEG.
2. Make sure power is off from the appropriate power source.
3. To connect the wires, hold the bare metal leads together and place a wire nut over them, then twist clockwise until tight. For all these connections, use the wire nuts provided.
4. Connect the ground wire from 120V power source to the ground wire from battery heater.
5. Using wire nuts provided connect the white wire and black wire from the battery heater as follows:
  - The white (common) power wire from 120V power source to 1st wire from the battery heater.
  - The wire from load side of thermostat to 2nd wire from the battery heater.

### ▲ CAUTION!

▲ **Be sure no bare wire or wire strands are visible after making connections.**

6. Push all wires and wire nuts into junction box.
7. Assemble junction box cover to junction box.
8. Reconnect battery cables to battery posts. Connect the positive cable first to the battery post indicated by (+) or POS.

*Figure 1.13 – Battery Warmer Kit*

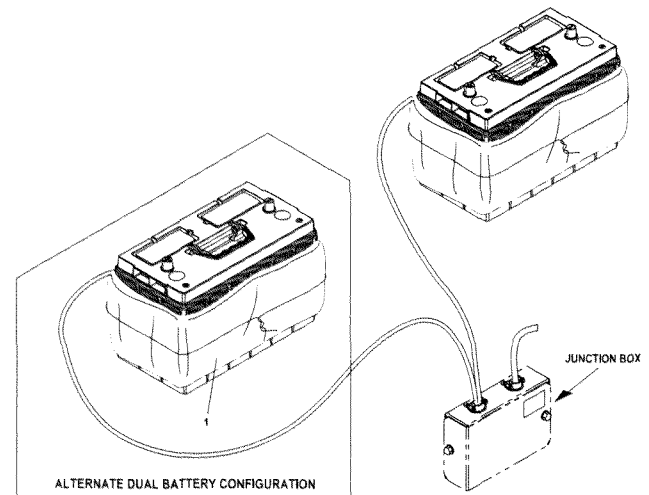

### BATTERY CHARGERS

There are two types of battery chargers available: 2.5-amp and 10-amp (nine-amp UL) rated. The 2.5-amp charger is 12 VDC only. The 10-amp is available as 12 VDC or 24 VDC, as appropriate for the engine's DC system voltage. These chargers are UL component recognized for use on these generator sets.

Both of the chargers are fully automatic float types and are fully fuse protected (input and output). They have automatic current limiting to reduce risk of overcharging, and have automatic maintenance of charge voltage. Therefore, they can be connected to the batteries continuously.

The chargers require the connection of a battery in order to turn on. The battery provides boost voltage for the charger, so a completely dead battery will not allow the charger to operate. The boost required is approximately nine to 11 volts for a 12 VDC system and 18 to 22 volts for a 24 VDC system. If the battery is below the boost voltage, it needs to be replaced.

They are not water resistant, so they must be installed within a rain resistant enclosure.

## STATIONARY EMERGENCY GENERATOR INSTALLATION

### ⚠ DANGER!

**⚠** Connecting this generator to an electrical system normally supplied by an electric utility shall be by means of a transfer switch (such as the "GTS" type transfer switch), so as to isolate the electric system from the utility distribution system when the generator is operating. Failure to isolate the electric system by these means will result in damage to the generator and may also result in injury or death to utility workers due to backfeed of electrical energy.

### ⚠ CAUTION!

**⚠** If an open bottom is used, the engine-generator is to be installed over non-combustible materials and should be located such that combustible materials are not capable of accumulating under the generator set.

Only qualified, competent installation contractors or electricians thoroughly familiar with applicable codes, standards and regulations should install this stationary emergency electric power system. The installation must comply strictly with all codes, standards and regulations pertaining to the installation.

This genset must be installed on a level surface. The base frame must be level within two (2) inches all around.

### ⚠ CAUTION!

**⚠** After the system has been installed, do nothing that might render the installation in non-compliance with such codes, standards and regulations.

#### NOTE:

For more information about the installation of a stationary emergency system, order *Engine-Generator Stationary emergency Electric Power Systems Installer's Guide and Reference Manual (part #046622)* from an Authorized Service Dealer.

### NFPA STANDARDS

The following published standards booklets pertaining to stationary emergency electric systems are available from the National Fire Protection Association (NFPA), Batterymarch Park, Quincy, MA 02269 or [www.nfpa.org](http://www.nfpa.org).

- NFPA No. 37, STATIONARY COMBUSTION ENGINES AND GAS TURBINES.
- NFPA No. 76A, ESSENTIAL ELECTRICAL SYSTEMS FOR HEALTH CARE FACILITIES.
- NFPA No. 220, STANDARD TYPES OF BUILDING CONSTRUCTION
- NFPA No. 68, GUIDE FOR EXPLOSION VENTING
- NFPA No. 70, NATIONAL ELECTRICAL CODE.

- NFPA No. 30, FLAMMABLE AND COMBUSTIBLE LIQUIDS CODE.
- NFPA No. 10, INSTALLATION, MAINTENANCE AND USE OF PORTABLE FIRE EXTINGUISHERS.

### OTHER PUBLISHED STANDARDS

In addition to NFPA standards, the following information pertaining to the installation and use of stationary emergency electric systems is available:

- Article X, NATIONAL BUILDING CODE, available from the American Insurance Association, 85 John Street, New York, N.Y. 10038.
- AGRICULTURAL WIRING HANDBOOK, obtainable from the Food and Energy Council, 909 University Avenue, Columbia, MO, 65201.
- ASAE EP-364.2, INSTALLATION AND MAINTENANCE OF FARM STANDBY ELECTRIC POWER, available from the American Society of Agricultural Engineers, 2950 Niles Road, St. Joseph, MI 49085.
- A52.1, AMERICAN NATIONAL STANDARD FOR CHIMNEYS, FIREPLACES AND VENTING SYSTEMS, available from the American National Standard Institute, 1430 Broadway, New York, N.Y. 10018.

## BASIC STATIONARY EMERGENCY ELECTRIC SYSTEM

Figure 2.1 shows a schematic diagram of a basic stationary emergency electric system. Both the UTILITY power supply and the STANDBY (GENERATOR) output are connected to an approved transfer switch. The transfer switch is required by electrical code and serves the following functions:

- Permits the LOAD circuits to be connected to only one power supply at a time.
- Prevents electrical backfeed between the generator and the UTILITY power circuits.

Notice that both the STANDBY and the UTILITY power supplies to the transfer switch are protected against overload by a main line circuit breaker.

Figure 2.1 – Basic Stationary Emergency Electric System

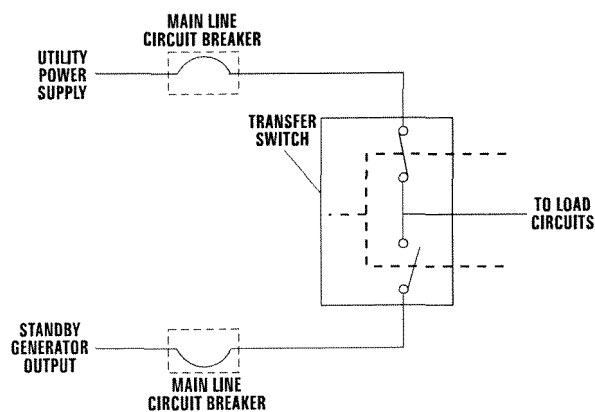

## Installation

### EMERGENCY CIRCUIT ISOLATION METHOD

This prevents overloading the generator by keeping electrical loads below the wattage/amperage capacity of the generator. If the generator is powering only critical loads, within the wattage/amperage capacity, during utility power outages, consider using the emergency circuit isolation method.

Critical electrical loads are grouped together and wired into a separate "Emergency Distribution Panel." Load circuits powered by that panel are within the wattage/amperage capacity of the generator set. When this method is used, it is difficult to overload the generator. The transfer switch must meet the following requirements:

- It must have an ampere rating equal to the total amperage rating of the emergency distribution panel circuit.
- Have it installed between the building's main distribution panel and the emergency distribution panel.

### TOTAL CIRCUIT ISOLATION METHOD

When a generator capable of powering all electrical loads in the circuit is to be installed, use the "Total Circuit Isolation Method." It is possible for the generator to be overloaded when this isolation method is employed. The following apply to the transfer switch in this type of system.

- Ampere rating of the transfer switch must equal the ampere rating of the normal incoming utility service.
- The transfer switch is installed between the utility service entrance and the building distribution panel.

### GROUNDING THE GENERATOR

The generator set must be grounded in accordance with the National Electrical Code and any state or local requirements.

#### **▲ DANGER!**

- ▲ Do not connect the ground wire to any pipe that carries a flammable or explosive substance – FIRE or an EXPLOSION may result.

Figure 2.2 – Grounding Electrode Terminal (typical)

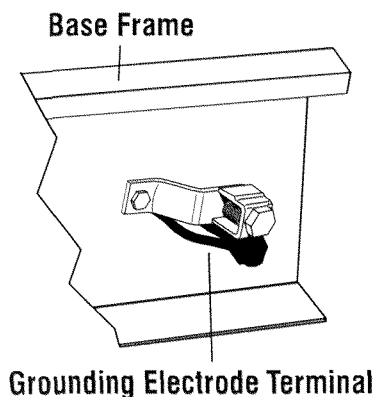

### GENERATOR AC NEUTRAL CONNECTIONS

Grounding is recommended only at one point in the system. Consult local building codes for proper neutral grounding requirements.

### TRANSFER SWITCH START SIGNAL CONNECTIONS

If the generator is to be installed with a standard automatic transfer switch, such as a GTS type switch, it will be necessary to connect the two-wire start control system.

Connect the two-wire start signal from the automatic transfer switch to the automatic start connection, which is located in the lower rear of the AC connection panel. Match wires 178 (0) and 183 in the transfer switch to 178 (0) and 183 on the terminal strip in the connection box. The conductors for the two-wire start circuit must be in their own conduit.

If the generator is to be installed with an HTS-type transfer switch, a different connection method is needed. Use shielded 2-wire communications cable (such as Belden #9460) to make the connection from the HTS transfer switch to the engine generator connection panel. This cable is to be routed in a separate conduit between the HTS transfer switch and the generator. The cable is to be connected as follows:

HTS transfer switch - 4 position terminal block, in the bottom of the transfer switch enclosure (labeled "comm. Ports").

Engine generator - terminal strip located in the lower rear of the AC connection panel. Connect the RS485+ and RS485- to the respective terminals in switch and generator. Do not connect the shield at the transfer switch end.

### BATTERY INSTALLATION

#### **▲ DANGER!**

- ▲ Stationary emergency generators installed with automatic transfer switches will crank and start automatically when NORMAL (UTILITY) source voltage is removed or is below an acceptable preset level. To prevent such automatic start-up and possible injury to personnel, do not connect battery cables until certain that normal source voltage at the transfer switch is correct and the system is ready to be placed into operation.
- ▲ Storage batteries give off explosive hydrogen gas. This gas can form an explosive mixture around the battery for several hours after charging. The slightest spark can ignite the gas and cause an explosion. Such an explosion can shatter the battery and cause blindness or other injury. Any area that houses a storage battery must be properly ventilated. Do not allow smoking, open flame, sparks or any spark producing tools or equipment near the battery.



**!** Battery electrolyte fluid is an extremely caustic sulfuric acid solution that can cause severe burns. Do not permit fluid to contact eyes, skin, clothing, painted surfaces, etc. Wear protective goggles, protective clothing and gloves when handling a battery. If fluid is spilled, flush the affected area immediately with clear water.

### **▲ WARNING!**

**!** Do not dispose of the battery in a fire. The battery is capable of exploding.

**!** Do not open or mutilate the battery. Released electrolyte can be toxic and harmful to the skin and eyes.

**!** The battery represents a risk of high short circuit current. When working on the battery, always remove watches, rings or other metal objects, and only use tools that have insulated handles.

### **VENTED BATTERIES**

#### **▲ CAUTION!**

**!** The electrolyte is a dilute sulfuric acid that is harmful to the skin and eyes. It is electrically conductive and corrosive. The following procedures are to be observed:

- Wear full eye protection and protective clothing,
- Where electrolyte contacts the skin, wash it off immediately with water,
- Where electrolyte contacts the eyes, flush thoroughly and immediately with water and seek medical attention, and
- Spilled electrolyte is to be washed down with an acid-neutralizing agent. A common practice is to use a solution of one pound (500 grams) bicarbonate of soda to one gallon (4 liters) of water. The bicarbonate of soda solution is to be added until the evidence of reaction (foaming) has ceased. The resulting liquid is to be flushed with water and the area dried.

**!** Lead acid batteries present a risk of fire because they generate hydrogen gas. The following procedure are to be followed:

- **DO NOT SMOKE** when near batteries,
- **DO NOT** cause flame or spark in battery area, and
- Discharge static electricity from body before touching batteries by first touching a grounded metal surface.

Servicing of batteries is to be performed or supervised by personnel knowledgeable of batteries and the required precautions. Keep unauthorized personnel away from batteries.

For recommended batteries, see "Specifications." All batteries must be at 100 percent state-of-charge before they are installed on the generator.

When using maintenance-free batteries, it is not necessary to check the specific gravity or electrolyte level. Have these procedures performed at the intervals specified in Section 4, "Maintenance." A negative ground system is used. Battery connections are shown on the wiring diagrams. Make sure all batteries are correctly connected and terminals are tight. Observe battery polarity when connecting batteries to the generator set.

#### **NOTE:**

**Damage will result if the battery connections are made in reverse.**

### **PREPARATION BEFORE START-UP**

The instructions in this section assume that the stationary emergency generator has been properly installed, serviced, tested, adjusted and otherwise prepared for use by a competent, qualified installation contractor. Be sure to read the "Safety Rules" on Pages 2 and 3, as well as all other safety information in this manual, before attempting to operate this (and related) equipment.

### **PRIOR TO INITIAL START-UP**

#### **▲ CAUTION!**

**!** Prior to initially starting the generator, it must be properly prepared for use. Any attempt to crank or start the engine before it has been properly serviced with the recommended types and quantities of engine fluids (oil, coolant, fuel, etc.) may result in an engine failure.

Before starting the generator for the first time, the installer must complete the following procedures. For follow-up maintenance information and/or service intervals, please refer to Section 4, "Maintenance," and the "Service Schedule".

#### **Transfer Switch**

If this generator is used to supply power to any electrical system normally powered by an electric utility, the National Electrical Code requires that a transfer switch be installed. The transfer switch prevents electrical backfeed between two different electrical systems. (For additional information, see the applicable transfer switch manual for this unit.) The transfer switch, as well as the generator and other standby components, must be properly located and mounted in strict compliance with applicable codes, standards and regulations.

## Operation

### Fuel System

Make sure the fuel supply system to the generator (a) delivers the correct fuel at the correct pressure and (b) is properly purged and leak tested according to code. No fuel leakage is permitted. See "Specifications" for more information.

If the unit has been idle for a long period of time, or if the fuel lines or system components have been removed and reinstalled, the fuel system may require bleeding to remove air from the system. Air in the fuel system causes hard starting and rough operation. All fuel system lines must be installed and must be tight. A loose line may show no sign of leakage, but may draw air into the system.

#### ▲ CAUTION!

**▲ Use a suitable container to catch the fuel that will spill during system bleeding process. Clean up all spilled fuel after bleeding.**

### Generator Set Lubrication

Check the engine crankcase oil level before operating and add oil to the proper level – the dipstick "FULL" mark. Never operate the engine with the oil level below the dipstick "ADD" mark. See "Specifications" and "Engine Oil Recommendations".

Check the oil level in the generator gearbox (if so equipped) prior to initial use and at the intervals indicated by the "Service Schedule." The recommended oil is SAE 90 gear lubricant.

Also, if the engine is equipped with a mechanical governor, make sure the governor is properly lubricated with clean engine oil.

### Engine Coolant

Have the engine cooling system properly filled with the recommended coolant mixture. Check the system for leaks and other problems. See "Specifications" and "Coolant".

### Belt Tension

Check the engine fan belt tension and condition prior to placing the unit into service and at recommended intervals. Belt tension is correct when a force of approximately 22 pounds (10 kg), applied midway between pulleys, deflects the belt about 3/8- to 5/8-inch (10 to 16 mm). This does not apply to automatic belt tensioning systems.

### Electrical System

Make sure the generator is properly connected to an approved earth ground.

Make sure the generator battery is fully charged, properly installed and interconnected, and ready for use.

Check to ensure that there are no loose electrical connections. Restrain any loose wires to keep them clear of any moving generator set components.

### Rodent Protection

Make sure the four, 3-inch diameter cap plugs are properly installed in the tie-down holes in the side rails of the unit's base frame (Figure 2.3). The cap plugs are shipped in a plastic bag located in the lower connection box. These plugs are needed to prevent rodents from accessing the interior of the generator set. On acoustic units, cap plugs also are needed to stay within noise specification limits.

**Figure 2.3 – Base Frame Cap Plugs**

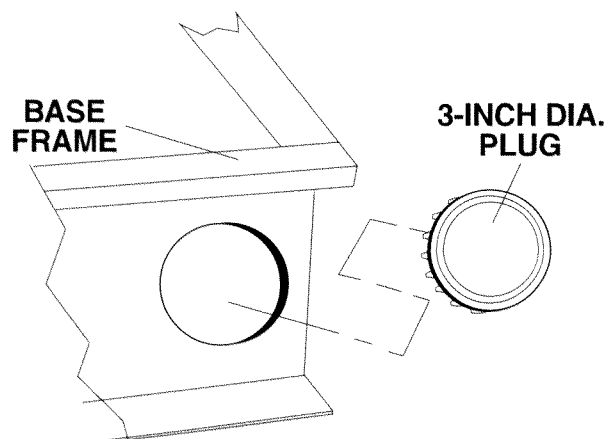

### START-UP INSPECTION

A standard form titled "Start-up Inspection for Stationary Emergency Power Systems" (part no. 067377) should be completed by the installation technician or engineer. As stated on the form, inspections are to be accomplished only by factory-trained personnel.

The technician performing the install should then scan and e-mail the completed form to [service@generac.com](mailto:service@generac.com). The form can also be filled out at a dealer's Generac website.

## **GENERATOR CONTROL AND OPERATION**

Refer to the appropriate control panel operator's manual for this unit.

## **OPERATING UNIT WITH MANUAL TRANSFER SWITCH**

If the generator was installed in conjunction with a transfer switch capable of manual operation only, the following procedure applies. A manually operated transfer switch is one that will not provide automatic start-up and does not include an intelligence circuit.

### ENGINE START-UP AND TRANSFER

For additional information, refer to the applicable control panel manual for this unit, as well as any literature pertaining to the transfer switch.

## **⚠ DANGER!**

- ⚠ The Maintenance Disconnect Switch and the AUTO/OFF/MANUAL switches (if so equipped) must be set properly, or the generator will crank and start as soon as the UTILITY power to the transfer switch is turned off. Refer to applicable control panel and transfer switch manuals for more information.**
- ⚠ Do not proceed until certain that utility source voltage is available to the transfer switch and the transfer switch main contacts are set to UTILITY.**
- ⚠ Do not attempt manual operation until all power supplies to the transfer switch have been positively turned off, or extremely dangerous — possibly lethal — electrical shock will result.**
- ⚠ Transfer switch enclosure doors should be kept closed and locked. Only authorized personnel should be allowed access to the transfer switch interior. Extremely high and dangerous voltages are present in the transfer switch.**

In order to manually transfer load from the utility source to the generator, follow these directions:

- Turn OFF or disconnect the utility power circuit to the transfer switch, using the means provided (such as the utility source main line circuit breaker).
- Set the transfer handle to its UTILITY (NORMAL) position with load circuits connected to the utility power supply.
- Set the stationary emergency generator's main line circuit breaker to its OFF (or OPEN) position.
- Start the generator.
- Let engine stabilize and warm up.
- Check all applicable instrument and gauge readings. When certain that all readings are correct, move the transfer switch manual handle to its STANDBY (GENERATOR) position, i.e., load circuits supplied by the generator.
- Set the stationary emergency generator's main line circuit breaker to its ON (or CLOSED) position.
- Load circuits are now powered by the stationary emergency generator.

## **RETRANSFER AND SHUTDOWN**

For additional information, refer to the applicable control panel manual for this unit, as well as any literature pertaining to the transfer switch.

To manually transfer the load back to the utility power source and shut down the generator, follow these directions:

- Set the stationary emergency generator's main line circuit breaker to its OFF (or OPEN) position.
- Manually move the transfer switch handle to its UTILITY (NORMAL) position, i.e., load circuits connected to the utility.

- Turn ON the utility power supply to the transfer switch, using the means provided (such as the utility power source main line circuit breaker).
- Let the generator run at no-load for a few minutes to stabilize internal temperatures.
- Shut down the generator.

## **OPERATING UNIT WITH AUTOMATIC TRANSFER SWITCH**

If the generator has been installed along with an automatic transfer switch, such as a GTS-type switch, the engine may be started and stopped automatically or manually.

### **NOTE:**

Refer to the applicable manual for the transfer switch and to "Transfer Switch Start Signal Connections". In addition, please note the dangers under "Engine Start-up and Transfer."

## **SERVICE SCHEDULE**

### **AUTHORIZED OPERATOR MAINTENANCE FUNCTIONS**

#### **Every Month or 100 Hours (whichever comes first)**

- Test stationary emergency generator system.
- Inspect battery (batteries) and cables.
- Check engine oil level.
- Check gearbox oil level (if so equipped).
- Check engine coolant level.
- Check generator ground connections.
- Test/inspect starting aids.

#### **Every Three Months or Every 120 Hours (whichever comes first)**

- Inspect and test fuel system and connections.
- Inspect exhaust system.
- Inspect/test fuel supply system.

### **AUTHORIZED SERVICE TECHNICIAN MAINTENANCE FUNCTIONS**

#### **After First 30 Hours of Operation**

- Inspect wiring.
- Change engine crankcase oil and oil filter.
- Inspect engine fan belts.
- Inspect battery (batteries) and cables.

#### **Every Six Months or Every 200 Hours (whichever comes first)**

- Lubricate engine controls.
- Service engine air cleaner.
- Service engine fuel filter.
- Inspect AC generator.
- Test engine safety controls.
- Inspect fan belts.
- Check engine coolant level.
- Inspect engine cooling system hoses.

## Maintenance

- Check optional starting aids.
- Check battery (batteries).
- Check engine compression.
- Check electrical connections.
- Check/test annunciator panel.
- Perform operational test.

### Annually or Every 600 Hours (whichever comes first)

- Change engine oil and filter.
- Inspect all wiring.
- Test engine starter operation.
- Drain water from fuel tank.
- Retorque fan bolts.
- Drain and refill gearbox (if so equipped).

### Every Two Years

- Replace all rubber hoses.
- Replace engine fan belts.
- Inspect the Stationary Emergency Generator System.
- Drain, flush, refill cooling system.

### Every 1,000 Operating Hours

- Inspect engine DC alternator.
- Inspect engine starter.
- Retorque engine mounting brackets.
- Remove/test fuel injection pump.
- Remove/test cooling system thermostat.

### As Required

- Bleed engine fuel system.

## PERIODIC MAINTENANCE

A rigorous program of scheduled periodic maintenance should be established and maintained. Such a program, if adhered to diligently, will provide added assurance that the power system functions properly when it is needed.

Keeping a "Maintenance Log" is highly recommended. Such a log should be a continuous record of repairs, parts replacements, gauge and instrument readings during operational tests, etc.

The manufacturer requires that a "Scheduled Maintenance Plan" be established between the user of this equipment and the installing Authorized Service Dealer. Under this agreement, (Part No. 053263), an Authorized Service Technician performs prestart and engine running tests and checks at six-month and one-year intervals. Ask an Authorized Service Dealer about this agreement.

The tasks listed in the "Service Schedule" cover the minimum recommended maintenance requirements for this equipment.

Note that many of the tests and checks listed in the schedule are to be performed only by an Authorized Service Technician. Fluid capacities and recommendations, as well as other applicable specifications, are listed in "Specifications".

## TEST STATIONARY EMERGENCY GENERATOR SYSTEM OPERATION AND COMPONENTS

An authorized operator should test the operation of the stationary emergency generator system and inspect its components monthly (or 100 hours). This should include inspecting the transfer switch for evidence of arcing, and pitted or burned contacts; inspecting wiring and grounding connections (see "Grounding the Generator"); and ensuring that starting devices are operational. During this operational test, all instrument and gauge readings should be recorded in a "Maintenance Log." The transfer system also should be tested at this time; the engine should be run at least 30 minutes and any discrepancies corrected immediately.

Every six months (or 200 hours), an Authorized Service Technician should perform a system operational test.

## INSPECT BATTERY

### **⚠ DANGER!**

**⚠ Stationary emergency generators installed with automatic transfer switches will crank and start automatically when NORMAL (UTILITY) source voltage is removed or is below an acceptable preset level. To prevent such automatic start-up and possible injury to personnel, do not connect battery cables until certain that normal source voltage at the transfer switch is correct and the system is ready to be placed into operation.**

**⚠ Storage batteries give off explosive hydrogen gas. This gas can form an explosive mixture around the battery for several hours after charging. The slightest spark can ignite the gas and cause an explosion. Such an explosion can shatter the battery and cause blindness or other injury. Any area that houses a storage battery must be properly ventilated. Do not allow smoking, open flame, sparks or any spark producing tools or equipment near the battery.**

**⚠ Battery electrolyte fluid is an extremely caustic sulfuric acid solution that can cause severe burns. Do not permit fluid to contact eyes, skin, clothing, painted surfaces, etc. Wear protective goggles, protective clothing and gloves when handling a battery. If fluid is spilled, flush the affected area immediately with clear water.**

### **⚠ WARNING!**

**⚠ Do not dispose of the battery in a fire. The battery is capable of exploding.**

**⚠ Do not open or mutilate the battery. Released electrolyte can be toxic and harmful to the skin and eyes.**

**⚠ The battery represents a risk of high short circuit current. When working on the battery, always remove watches, rings or other metal objects, and only use tools that have insulated handles.**

An authorized operator should inspect the engine battery system monthly (or 100 hours). At this time, the battery fluid level should be checked and distilled water added if needed. Battery cables and connections also should be inspected for cleanliness and corrosion.

Once every six months (or 200 hours), an Authorized Service Technician should inspect the battery system. At this time the battery condition and state of charge should be checked using a battery hydrometer. The battery should be recharge or replaced as required.

## CHECK FLUIDS

An authorized operator should check the levels of engine oil, and engine coolant monthly (or 100 hours). The oil level should be maintained between the "FULL" and "ADD" marks on the engine dipstick. Recommended fluids are listed in the "Specifications" section.

Once annually (or at every 600 hour intervals), an authorized service technician should completely drain and refill the gearbox (if so equipped) using the following procedure (Figure 4.1):

1. Remove panel fuse and negative battery cable.
2. Remove the oil filler/vent cap.
3. Remove the drain plug and drain the oil into an appropriate container. Dispose of or recycle the oil properly.
4. Reinstall the oil drain plug.
5. To add oil to the gearbox, remove the oil level check plug.

**Figure 4.1 – Gearbox Oil Servicing Points**

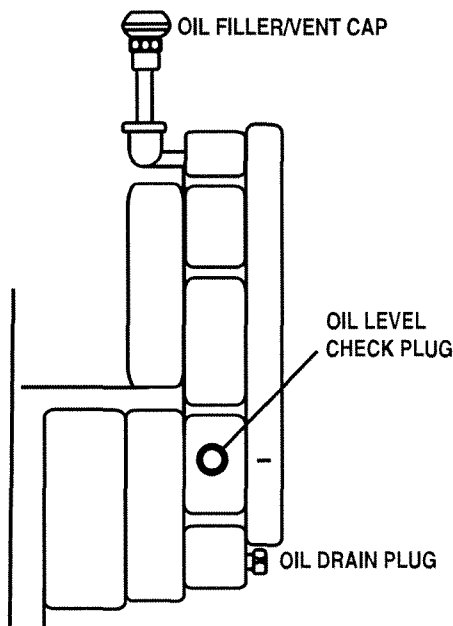

6. Add the recommended oil until it just starts to flow from the oil level check plug opening.
7. Finally, install and tighten the oil filler/vent cap and oil level check plug.
8. Re-install negative battery cable and panel fuse. Start unit and check for leaks.

## INSPECT EXHAUST SYSTEM

Every three months (or 120 hours), an authorized operator should inspect the entire exhaust system. Abnormal noise levels heard during each operational test may indicate a defective exhaust pipe or muffler. Any defective or leaking component should be repaired or replaced immediately by an Authorized Service Technician.

## INSPECT/TEST FUEL SUPPLY SYSTEM

Every three months (or 120 hours), an authorized operator should inspect and test the fuel supply system, as well as all fuel system connections. All connections must be tight and in good condition. A loose fuel system line may show no signs of leakage, but may draw air into the system causing rough operation and starting difficulties. Any defective or leaking component should be repaired or replaced immediately by an Authorized Service Technician.

## REPAIR PARTS

The latter portion of this manual consist of exploded views, parts lists and electrical data pertaining to this generator set. The parts lists consist of (a) an item number, (b) a part number, (c) the quantity required, and (d) a description of the part. The item number corresponds to an identical number on the exploded view drawing.

## HOW TO ORDER PARTS

To order a replacement part, locate the part in the applicable exploded view. Contact an Authorized Service Dealer (call 800-333-1322 to locate one in the area) and provide the following information:

- The generator model number.
- The generator identification code, which indicates the specific generator assembly for each unit.
- The part number and corresponding description from the applicable parts list in this manual.
- The applicable exploded view "Group" letter (A-H) and drawing number (five-digit number), which can be found on the exploded view drawing.

### **NOTE:**

**In most cases, repair parts can be obtained by providing the Authorized Service Dealer with the data label information and a description of the required part. If unable to locate either the data label or the construction document, describe the part needed and provide the unit's model number. This number can be found on the DATA LABEL attached to the generator's lower connection box.**

### 500 KW TO 600 KW STATIONARY EMERGENCY DIESEL ENGINE DRIVEN GENERATOR SETS

Following is a recommended maintenance schedule for stationary emergency diesel engine driven generator sets from 500 kW to 600 kW in size. The established intervals in the schedule are the maximum required when the unit is used in an average service application. They will need to be decreased (performed more frequently) if the unit is used in a severe application. Use the unit hour meter or calendar time, whichever occurs first, from the previous maintenance interval to determine the next required maintenance interval.

**NOTE:** Add 20% to all times noted for 12 cylinder or larger engines.

#### **▲ WARNING!**

- ▲ To prevent injury, disable the generator set from starting and/or connecting to the load by setting the control panel Auto-Off-Manual switch to the "Off" position, removing the control panel fuse, turning off the battery charger, and removing the negative battery cable before performing any maintenance. NOTE: The battery charger must be turned off BEFORE removing the battery cable to prevent an over current condition from burning out sensitive control panel components and circuits. Following all maintenance, reverse these steps to insure the unit is returned to standby setup for normal operation when required.**

### SERVICE MAINTENANCE INTERVAL INFORMATION

The various service maintenance intervals are designated by interval numbers as follows:

1. An early inspection of the generator set to insure it is ready to operate when required and to identify any potential problem areas. *Performed monthly or following each 10 hours of operation of the unit and requires approximately .5 man-hours per unit to complete.*
- 1A. A break-in service inspection of the generator set to insure it is ready to operate, transfer to, and carry the load when required, and to identify any potential problem areas. *Performed ONLY ONCE following the first six months or the first 50 hours of operation after purchase of the unit and requires approximately 2.5 man-hours per unit to complete.*
2. An operational inspection of the generator set to insure it is ready to operate and carry the load when required, and to identify any potential problem areas. *Performed semi-annually or following each 50 hours of operation of the unit and requires approximately 1.5 man-hours per unit to complete.*
3. A mid-level inspection of the generator set to insure it is ready to operate and carry the load when required, and to identify any potential problem areas. *Performed annually or following each 100 hours of operation of the unit and requires approximately 4.0 man-hours per unit to complete.*
4. A comprehensive inspection of the generator set to insure it is properly serviced and ready to operate and carry the load when required, and to identify any potential problem areas. *Performed biannually or following each 250 hours of operation of the unit and requires approximately 8.0 man-hours per unit to complete.*

Maint Level	Maintenance Interval	Maintenance Tasks	Task Completed Date/Initials
1	Every month or 10 hours of operation.  (Requires approximately <b>0.5 man hours</b> per unit)	1. Disable the unit from operating per the first page warning.	
		2. Check the engine oil level. Adjust as necessary.	
		3. Check the engine coolant level. Adjust as necessary.	
		4. Check the battery electrolyte level if accessible. Adjust as necessary.	
		5. Check the diesel fuel supply level. Adjust as necessary.	
		6. Check the air inlets and outlets for debris. Clean as necessary.	
		7. Visually inspect the unit looking for leaks, wear or damage, loose connections or components, and corrosion. Correct as necessary.	
		8. Return the unit to operational condition.	
Technician's Signature		Date Inspection Completed	
Unit Hour Meter Reading at Completion of the Inspection			

# Maintenance

Maint Level	Maintenance Interval	Maintenance Tasks	Task Completed Date/Initials
1A	<b>First 6 months or 50 hours of operation ONLY</b>  <b>(Requires approximately 2.5 man hours per unit)</b>	1. Disable the unit from operating per the first page warning.	
		2. Check the engine oil level. Adjust as necessary.	
		3. Check the engine coolant level. Adjust as necessary.	
		4. Check the battery electrolyte level if accessible. Adjust as necessary.	
		5. Check the diesel fuel supply level. Adjust as necessary.	
		6. Drain water and sediment from the diesel fuel tank.	
		7. Drain water from the diesel fuel line water separator if unit is equipped with one.	
		8. Check the air inlets and outlets for debris. Clean as necessary.	
		9. Visually inspect the unit looking for leaks, wear or damage, loose connections or components, and corrosion. Correct as necessary.	
		10. Initiate an automatic start and transfer to load of the unit, and exercise it for at least 1 hour looking for leaks, loose connections or components, and abnormal operating conditions. Correct as necessary.	
		11. Change the engine oil.	
		12. Replace the engine oil filter(s).	
		13. Replace the engine fuel filter(s).	
		14. Return the unit to stand-by setup for operation when required.	
<b>Technician's Signature</b>		<b>Date Inspection Completed</b>	
<b>Unit Hour Meter Reading at Completion of the Inspection</b>			



## Maintenance

Maint Level	Maintenance Interval	Maintenance Tasks	Task Completed Date/Initials
2	Every 6 months or 50 hours of operation  (Requires approximately 1.5 man hours per unit)	1. Disable the unit from operating per the first page warning.	
		2. Check the engine oil level. Adjust as necessary.	
		3. Check the engine coolant level. Adjust as necessary.	
		4. Check the battery electrolyte level if accessible. Adjust as necessary.	
		5. Check the diesel fuel supply level. Adjust as necessary.	
		6. Drain water and sediment from the diesel fuel tank.	
		7. Drain water from the diesel fuel line water separator if unit is equipped with one.	
		8. Check the air inlets and outlets for debris. Clean as necessary.	
		9. Visually inspect the unit looking for leaks, wear or damage, loose connections or components, and corrosion. Correct as necessary.	
		10. Initiate an automatic start and transfer to load of the unit, and exercise it for at least 1 hour looking for leaks, loose connections or components, and abnormal operating conditions. Correct as necessary.	
		11. Return the unit to standby setup for operation when required.	
Technician's Signature		Date Inspection Completed	
Unit Hour Meter Reading at Completion of the Inspection			

# Maintenance

Maint Level	Maintenance Interval	Maintenance Tasks	Task Completed Date/Initials
3	Every 12 months or 100 hours of operation  (Requires approximately 4.0 man hours per unit)	1. Disable the unit from operating per the first page warning.	
		2. Check the engine oil level. Adjust as necessary.	
		3. Check the engine coolant level. Adjust as necessary.	
		4. Check the engine coolant thermal protection level. Correct as necessary.	
		5. Check the diesel fuel supply level. Adjust as necessary.	
		6. Drain water and sediment from the diesel fuel tank.	
		7. Drain water from the diesel fuel line water separator if unit is equipped with one.	
		8. Check the air inlets and outlets for debris. Clean as necessary.	
		9. Check the battery electrolyte level if accessible. Adjust as necessary.	
		10. Check the battery posts, cables, and charger for loose connections, corrosion, and proper operation. Correct as necessary.	
		11. Check the unit wiring for loose connections, corrosion, and damage. Correct as necessary.	
		12. Check the engine accessory drive belts for wear, weather cracking, and damage. Replace as necessary.	
		13. Test the unit safety devices (alarms, shutdowns, etc.) for proper operation. Correct and/or adjust as necessary.	
		14. Perform an oil analysis (send a sample to a lab for results). Change the engine oil and filters if the analysis results indicate this is required.	
		15. Visually inspect the unit looking for leaks, wear or damage, loose connections or components, and corrosion. Correct as necessary.	
		16. Start and exercise the unit under full rated load for at least 2 hours looking for leaks, loose connections or components, and abnormal operating conditions. Correct as necessary.	
		17. Return the unit to standby setup for operation when required.	
Technician's Signature		Date Inspection Completed	
Unit Hour Meter Reading at Completion of the Inspection			

Maint Level	Maintenance Interval	Maintenance Tasks	Task Completed Date/Initials
4	<b>Every 24 months or 250 hours of operation</b>  <b>(Requires approximately 8.0 man hours per unit)</b>	1. Disable the unit from operating per the first page warning.	
		2. Check the engine oil level. Adjust as necessary.	
		3. Check the engine coolant level. Adjust as necessary.	
		4. Check the engine coolant thermal protection level. Correct as necessary.	
		5. Check the diesel fuel supply level. Adjust as necessary.	
		6. Drain water and sediment from the diesel fuel tank.	
		7. Drain water from the diesel fuel line water separator if unit is equipped with one.	
		8. Check the air inlets and outlets for debris. Clean as necessary.	
		9. Check the battery electrolyte level if accessible. Adjust as necessary.	
		10. Check the battery posts, cables, and charger for loose connections, corrosion, and proper operation. Correct as necessary.	
		11. Check the unit wiring for loose connections, corrosion, and damage. Correct as necessary.	
		12. Check the engine accessory drive belts for wear, weather cracking, and damage. Replace as necessary.	
		13. Check the engine valve clearance. Adjust as necessary.	
		14. Visually inspect the unit looking for leaks, wear or damage, loose connections or components, and corrosion. Correct as necessary.	
		15. Start and exercise the unit under full rated load for at least 2 hours looking for leaks, loose connections or components, and abnormal operating conditions. Correct as necessary.	
		16. Change the engine oil.	
		17. Replace the engine oil filter(s).	
<b>Maintenance Level 4 continued on next page.</b>			

# Maintenance

Maint Level	Maintenance Interval	Maintenance Tasks	Task Completed Date/Initials
4	Every 24 months or 250 hours of operation  (Requires approximately 8.0 man hours per unit)	18. Replace the engine fuel filter(s).	
		19. Replace the engine air filter(s).	
		20. Replace Engine Coolant.	
		21. Replace Coolant Hoses.	
		22. Visibly inspect flexible fuel lines and flexible air lines, if applicable, on this unit. Replace them if they seem worn, spongy or brittle.	
		23. Start the unit and exercise it for at least 15 minutes looking for leaks, loose connections or components, and abnormal operating conditions. Correct as necessary.	
		24. Return the unit to standby setup for operation when required.	
Technician's Signature		Date Inspection Completed	
Unit Hour Meter Reading at Completion of the Inspection			

**EPA EMISSION-RELATED CI GENERATOR MODEL WARRANTY**

Effective 01/01/2011, applicable to CI generator models equal to and larger than SD80.

Effective 01/01/2012, applicable to CI generator models equal to and larger than SD35.

Effective 01/01/2013, applicable to all CI generator models.

Your emission-related warranty covers only components whose failure would increase an engine's emissions of any regulated pollutant where they are designed, built, and equipped to be free from defects in materials and workmanship under applicable regulations of section 213 of the clean air act. To receive information about how to make an emission-related warranty claim, and how to make arrangements for authorized repairs call 1-800-333-1322 or [www.generac.com](http://www.generac.com). Emission-related warranty claims may be denied without proof of proper maintenance or use, accidents beyond the control of the manufacturer, or acts of God. Proper maintenance is specified in the owners manual. Usage is limited to stationary emergency operations and 100 hours per year for maintenance and readiness testing. The warranty period begins when the engine is placed into service. Warranty periods: Compression ignition engines rated > 25 HP is 5 years.

# Warranty

Effective 01/01/2011, applicable to CI generator models equal to and smaller than SD60.

Effective 01/01/2012, applicable to CI generator models equal to and smaller than SD30.

Effective 01/01/2013, not applicable to CI generator models.

**NOTE: This Emission Control Warranty Statement applies only to mobile (trailerized) non-road diesel engine powered generators (model year 2000) as follows: The EPA portion of this statement pertains to this product; The CARB portion of this statement pertains to this product only IF the generator size is (1) 15 kW or below OR (2) 130 kW or greater.**

## CALIFORNIA AND FEDERAL EMISSION CONTROL WARRANTY STATEMENT

### YOUR WARRANTY RIGHTS AND OBLIGATIONS

The California Air Resources Board (CARB) and the United States Environmental Protection Agency (EPA), together with Generac Power Systems, Inc. (Generac), are pleased to explain the Emission Control System Warranty on your new non-road diesel engine.\* New non-road diesel engines must be designed, built and equipped to meet stringent anti-smog standards for the state of California and the federal government. Generac will warrant the emission control system on your non-road diesel engine for the periods of time listed below provided there has been no abuse, neglect, unapproved modification or improper maintenance of your non-road diesel engine.

Your emission control system may include such parts as the fuel injection system and the air induction system. Also included may be hoses, belts, connectors and other emission-related assemblies. Generac will repair your non-road diesel engine at no cost to you for diagnosis, replacement parts and labor, should a warrantable condition occur.

### MANUFACTURER'S EMISSION CONTROL SYSTEM WARRANTY COVERAGE:

Emission control systems on 1996 and later model year non-road diesel engines are warranted for five years, or 3,000 hours of use, whichever occurs first. In the absence of an hourmeter, the said coverage is five years. If, during said warranty period, any emission-related component or system on your engine is found to be defective in materials or workmanship, repairs or replacement will be performed by a Generac Authorized Warranty Service Facility.

### PURCHASER'S/OWNER'S WARRANTY RESPONSIBILITIES:

As the non-road diesel engine purchaser/owner, you are responsible for the completion of all required maintenance as listed in your factory supplied Owner's Manual. For warranty purposes, Generac recommends that you retain all receipts covering maintenance of your non-road diesel engine. However, Generac cannot deny warranty solely due to lack of receipts or for your failure to ensure the completion of all scheduled maintenance.

As the non-road diesel engine purchaser/owner, you should, however, be aware that Generac may deny any and/or all warranty coverage or responsibility if your non-road diesel engine, or a part/component thereof, has failed due to abuse, neglect, improper maintenance or unapproved modifications, or the use of counterfeit and/or "grey market" parts not made, supplied or approved by Generac.

Your engine is designed to operate on diesel fuel only. Use of any other fuel may result in your engine no longer operating in compliance with federal or California emission requirements.

**You are responsible for contacting a Generac Authorized Warranty Service Facility as soon as a problem occurs.** The warranty repairs should be completed in a reasonable amount of time, not to exceed 30 days.

Warranty service can be arranged by contacting either your selling dealer or a Generac Authorized Warranty Service Facility. To locate the Generac Authorized Warranty Service Facility nearest you, call our toll-free number:

**1-800-333-1322**

**IMPORTANT NOTE:** This Warranty statement explains your rights and obligations under the Emission Control System Warranty (ECS Warranty), which is provided to you by Generac pursuant to federal and California law. See also the "Generac Limited Warranties for Generac Power Systems, Inc.," which is enclosed herewith on a separate sheet, also provided to you by Generac. The ECS Warranty applies **only** to the emission control system of your new non-road diesel engine. If there is any conflict in terms between the ECS Warranty and the Generac Warranty, the ECS Warranty shall apply except in circumstances where the Generac Warranty may provide a longer warranty period. Both the ECS Warranty and the Generac describe important rights and obligations with respect to your new non-road diesel engine.

Warranty service can be performed only by a Generac Authorized Warranty Service Facility. When requesting warranty service, evidence must be presented showing the date of sale to the original purchaser/owner.

**If you have any questions regarding your warranty rights and responsibilities, you should contact Generac at the following address:**

**ATTENTION WARRANTY DEPARTMENT  
GENERAC POWER SYSTEMS, INC.  
211 MURPHY DRIVE  
EAGLE, WI 53119**

# Warranty

## GENERAC POWER SYSTEMS STANDARD TWO-YEAR BASIC LIMITED WARRANTY FOR STANDBY POWER SYSTEMS

NOTE: ALL UNITS MUST HAVE A START-UP INSPECTION PERFORMED BY AN AUTHORIZED GENERAC DEALER.

For a period of two (2) years or two thousand (2,000) hours of operation from the date of start up, which ever occurs first, Generac Power Systems, Inc. (Generac) will, at its option, repair or replace any part(s) which, upon examination, inspection, and testing by Generac or an Authorized/Certified Generac Dealer, or branch thereof, is found to be defective under normal use and service, in accordance with the warranty schedule set forth below. Repair or replacement pursuant to this limited warranty shall not renew or extend the original warranty period. Any repaired product shall be warranted for the remaining original warranty period only. Any equipment that the purchaser/owner claims to be defective must be examined by the nearest Authorized/Certified Generac Dealer, or branch thereof. This warranty applies only to Generac Generators used in "Standby" applications, as Generac has defined Standby, provided said generator has been initially installed and/or inspected on-site by an Authorized/Certified Generac Dealer, or branch thereof. It is highly recommended that scheduled maintenance, as outlined by the generator owner's manual, be performed by an Authorized/Certified Generac Dealer, or branch thereof. This will verify service has been performed on the unit throughout the warranty period. This warranty is limited to and available only on Liquid-cooled units.

\*\*\*This warranty only applies to units sold for use in the US and Canada.\*\*\*

### WARRANTY SCHEDULE

YEAR ONE — Limited comprehensive coverage on mileage, labor, and parts listed.

• ALL COMPONENTS — ENGINE, ALTERNATOR AND TRANSFER SWITCH

YEAR TWO — Limited comprehensive coverage on parts listed.

• ALL COMPONENTS — ENGINE, ALTERNATOR AND TRANSFER SWITCH PARTS ONLY

### GEARBOX EQUIPPED UNITS - LIMITED GEARBOX COVERAGE

YEARS ONE THROUGH FIVE — Parts and labor coverage on gearbox and components.

YEARS SIX THROUGH TEN — Parts only coverage on gearbox and components.

### GUIDELINES:

1. Travel allowance is limited to 300 miles maximum, and 7.5 hours maximum (per occurrence), round trip, to the nearest authorized Generac Service Facility.
2. Warranty only applies to permanently wired and mounted units.
3. All warranty repairs, must be performed and/or addressed by an Authorized/Certified Generac Dealer, or branch thereof.
4. A Generac Transfer Switch is highly recommended to be used in conjunction with the generator set. If a Non-Generac Transfer Switch is substituted for use and directly causes damage to the generator set, no warranty coverage shall apply.
5. All warranty expense allowances are subject to the conditions defined in Generac's General Service Policy Manual.
6. Units that have been resold are not covered under the Generac Warranty, as this Warranty is not transferable.
7. Unit enclosure is only covered during the first year of the warranty provision.
8. Use of Non-Generac replacement part(s) will void the warranty in its entirety.
9. Engine coolant heaters (block-heaters), heater controls and circulating pumps are only covered during the first year of the warranty provision.
10. Generac may choose to Repair, Replace or Refund a piece of equipment.
11. Warranty Labor Rates are based on normal working hours. Additional costs for overtime, holiday or emergency labor costs for repairs outside of normal business hours will be the responsibility of the customer.
12. Warranty Parts shipment costs are reimbursed at ground shipment rates. Costs related to requests for expedited shipping will be the responsibility of the customer.
13. Batteries are warranted by the battery manufacturer.
14. Verification of required maintenance may be required for warranty coverage.

### THIS WARRANTY SHALL NOT APPLY TO THE FOLLOWING:

Any unit built/manufactured prior to July 1, 2004.

1. Costs of normal maintenance (i.e. tune-ups, associated part(s), adjustments, loose/leaking clamps, installation and start-up).
2. Any failure caused by contaminated fuels, oils, coolants/antifreeze or lack of proper fuels, oils or coolants/antifreeze.
3. Units sold, rated or used for "Prime Power", "Trailer Mounted" or "Rental Unit" applications as Generac has defined Prime Power, Trailer Mounted or Rental Unit. Contact a Generac Distributor for Prime Power, Trailer Mounted or Rental Unit definition and warranty.
4. Failures caused by any external cause or act of God such as, but not limited to, collision, fire, theft, freezing, vandalism, riot or wars, lightning, earthquake, windstorm, hail, volcanic eruption, water or flood, tornado, hurricane, terrorist acts or nuclear holocaust.
5. Products that are modified or altered in a manner not authorized by Generac in writing.
6. Failures due, but not limited to, normal wear and tear, accident, misuse, abuse, negligence, or improper installation, maintenance, or sizing.
7. Any incidental, consequential or indirect damages caused by defects in materials or workmanship, or any delay in repair or replacement of the defective part(s).
8. Damage related to rodent and/or insect infestation.
9. Failure due to misapplication, misrepresentation, or bi-fuel conversion.
10. Telephone, facsimile, cellular phone, satellite, Internet, or any other communication expenses.
11. Rental equipment used while warranty repairs are being performed (i.e. rental generators, cranes, etc.).
12. Modes of transportation deemed abnormal (refer to Generac General Service Policy Manual).
13. Steel enclosures that are rusting due to improper installation, location in a harsh or saltwater environment or scratched where integrity of paint applied is compromised.
14. Any and all expenses incurred investigating performance complaints unless defective Generac materials and/or workmanship were the direct cause of the problem.
15. Starting batteries, fuses, light bulbs, engine fluids, and overnight freight cost for replacement part(s).

THIS WARRANTY IS IN PLACE OF ALL OTHER WARRANTIES, EXPRESSED OR IMPLIED, SPECIFICALLY, GENERAC MAKES NO OTHER WARRANTIES AS TO THE MERCHANTABILITY OR FITNESS FOR A PARTICULAR PURPOSE. Any implied warranties which are allowed by law, shall be limited in duration to the terms of the express warranty provided herein. Some states do not allow limitations on how long an implied warranty lasts, so the above limitation may not apply to purchaser/owner.

GENERAC'S ONLY LIABILITY SHALL BE THE REPAIR OR REPLACEMENT OF PART(S) AS STATED ABOVE. IN NO EVENT SHALL GENERAC BE LIABLE FOR ANY INCIDENTAL, OR CONSEQUENTIAL DAMAGES, EVEN IF SUCH DAMAGES ARE A DIRECT RESULT OF GENERAC'S NEGLIGENCE. Some states do not allow the exclusion or limitation of incidental or consequential damages, so the above limitations may not apply to purchaser/owner. Purchaser/owner agrees to make no claims against Generac based on negligence. This warranty gives purchaser/owner specific legal rights. Purchaser/owner also may have other rights that vary from state to state.

Generac Power Systems, Inc. • P.O. Box 8 • Waukesha, WI 53187  
Ph: (262) 544-4811 • Fax: (262) 544-4851

# GROUP B

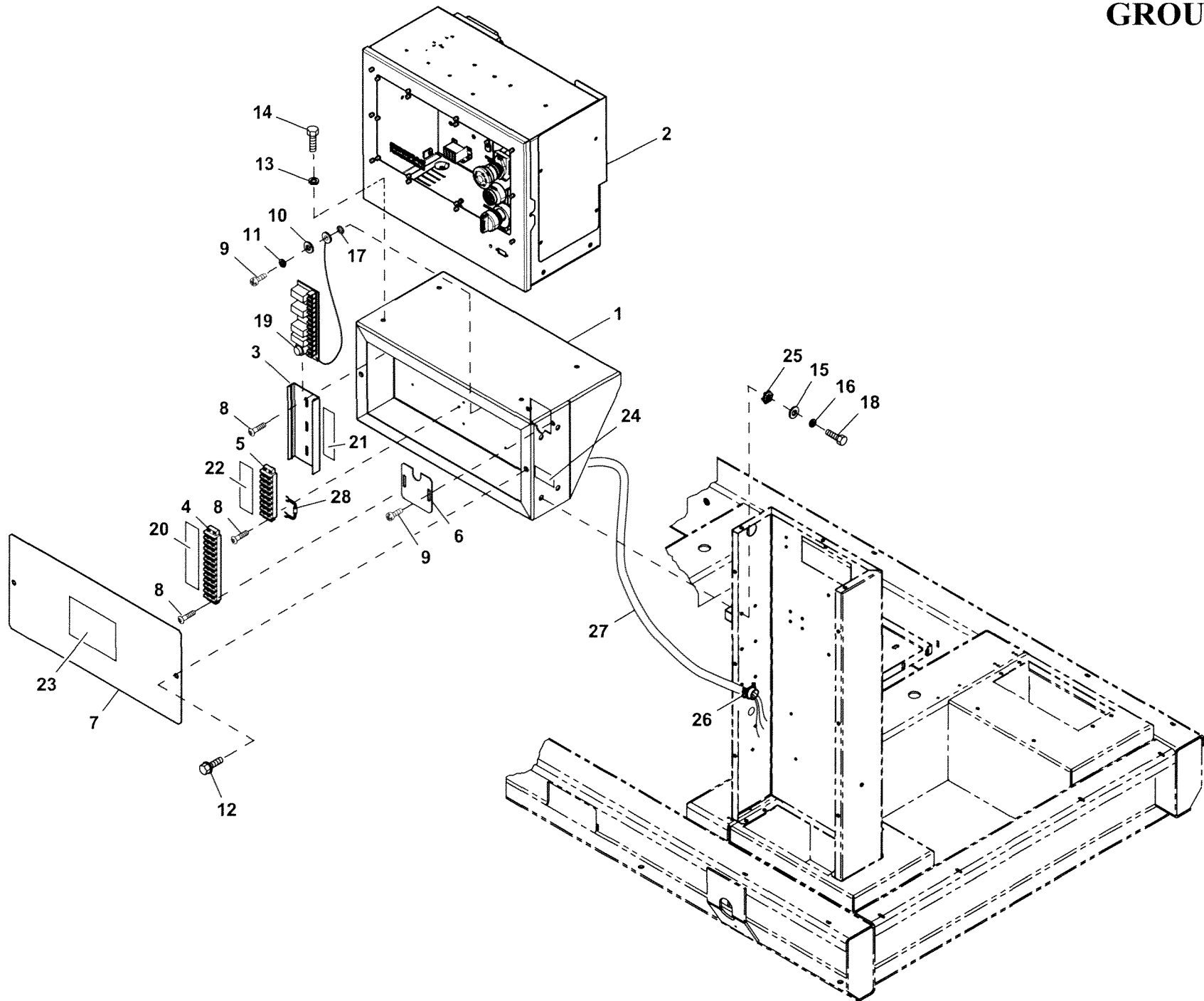



**EXPLODED VIEW: EV H-PNL 10A BC NO E-GOV DSL24**

**DRAWING #: 0J0288**

**GROUP B**

**APPLICABLE TO:**

ITEM	PART#	QTY.	DESCRIPTION
(1)1	0H84230ST0R	1	BRACKET H-PNL MOUNTIN CCI IND
2	0H4733E	1	ASSY H-PANEL 2.5A BATC 12V
	0G4140E	1	ASSY H-PANEL 10A BATC 12V
	0G4141E	1	ASSY H-PANEL NO BATC NO E-GOV
3	0E9764	1	RAIL SNAPTRACK PCB HOLDER BULK
(2)4	055911	REF	BLOCK TERM 20A 12 X 6 X 1100V
(2)5	057701	REF	BLOCK TERM 20A 8 X 6 X 1100V
(1)6	0J01360ST0R	1	PLATE, WIRE HARN BLOCKOFF
(1)7	0H96870ST0R	1	COVER, COSTOMER CONN H-PNL
8	0J5462	6	SCREW THTT M4-0.7 X 16 ZP
9	0J5464	3	SCREW THTT M5-0.8 X 16 ZP
10	051713	1	WASHER FLAT M5
11	049226	1	WASHER LOCK M5
12	0C2454	2	SCREW HWHT M6-1 X 16 N WA Z/JS
13	022097	4	WASHER LOCK M6-1/4
14	047411	4	SCREW HHC M6-1.0 X 16 C8.8
15	022145	4	WASHER FLAT 5/16-M8 ZINC
16	022129	4	WASHER LOCK M8-5/16
17	026850	1	WASHER LOCK EXT 1/4 STL
18	039253	4	SCREW HHC M8-1.25 X 20 C8.8
19	0G6962A	1	ASSY PCB RELAY 24VDC
	0G6962B	1	ASSY PCB RELAY 12VDC
20	0J0392	1	DECAL, TB1 LV CUSTOMER CONN
21	0J0398	1	DECAL, CONTACT RAT 30VAC/30VDC
22	0J0393	1	DECAL, TB2 LV CUSTOMER CONN
23	0J0545	1	DECAL, LV CUSTOMER CONN INSIDE
24	0J0575	1	DECAL, CUSTOMER WIRE #14
25	0C3168	1	WASHER LOCK SPECIAL 5/16
26	022206	1	FITTING CONDUIT STR 3/8
(3)27	0H9845	REF	HARN 390/520 CONBOX H-PANEL
(4)28	0C8065	1	DIODE ASSEMBLY
29	0J5349	REF	HARN 390/520 CONBOX 12V GAS H (NOT SHOWN)

- (1) SHEET METAL PARTS LISTED IN THE BOM TABLE ARE REPRESENTING GENERIC PARTS (NO COLOR).
  - **MANUFACTURING:** FOR CORRECT MATERIAL AND COLOR REFER TO AS400 BOM.
  - **CUSTOMER:** FOR CORRECT MATERIAL AND COLOR OF REPLACEMENT PARTS REFER TO "REPLACEMENT SHEET METAL PARTS ORDERING GUIDE-0H7169" INCLUDED IN THE MANUAL OR AVAILABLE ON THE GENERAC WEBSITE.
- (2) PART OF CONNECTION BOX HARNESS
- (3) HARNESS GETS WIRED TO LOAD CENTER IF EQUIPPED.
- (4) REFERENCE WIRE DIAGRAM FOR PROPER LOCATION.

# GROUP H

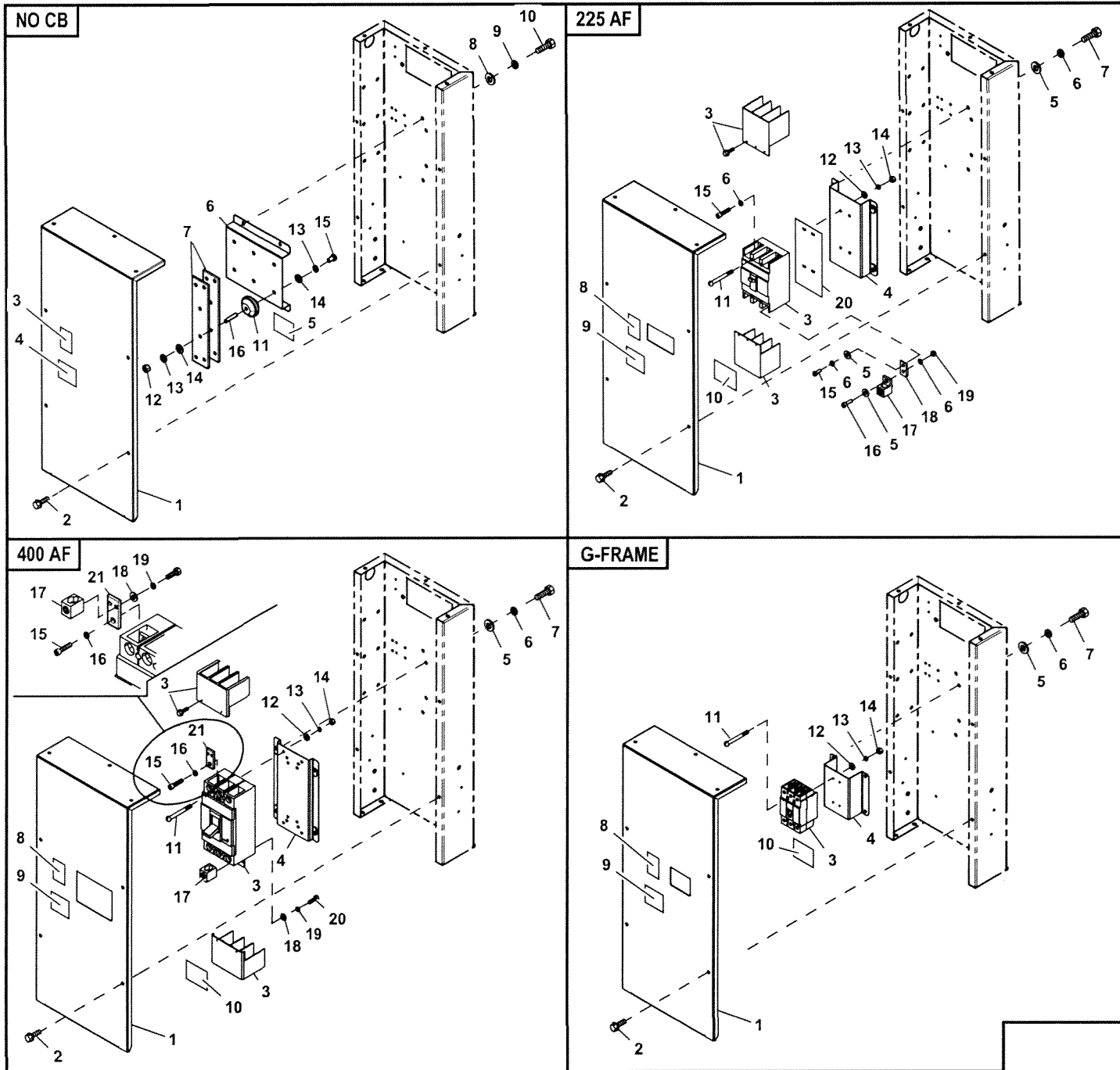

# GROUP H

F-FRAME

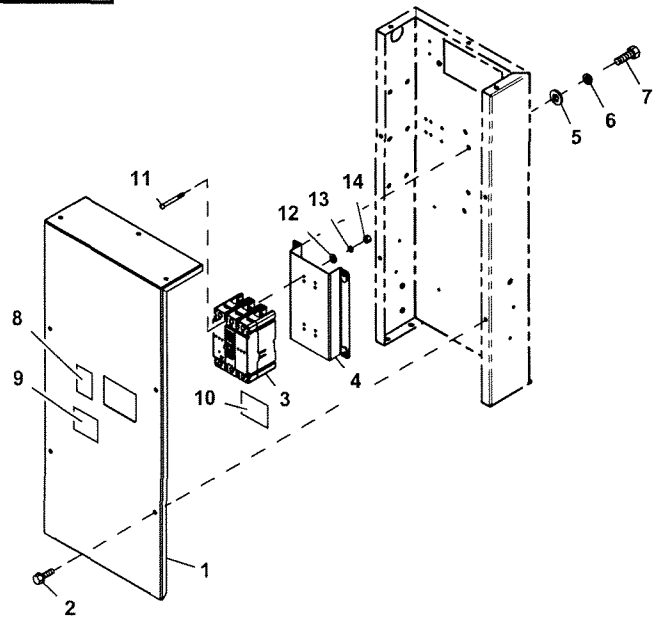

JG-FRAME

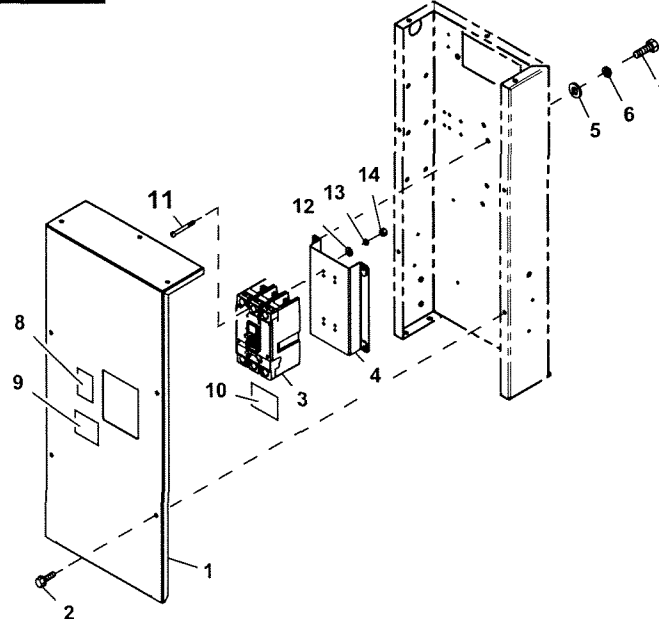

J-FRAME

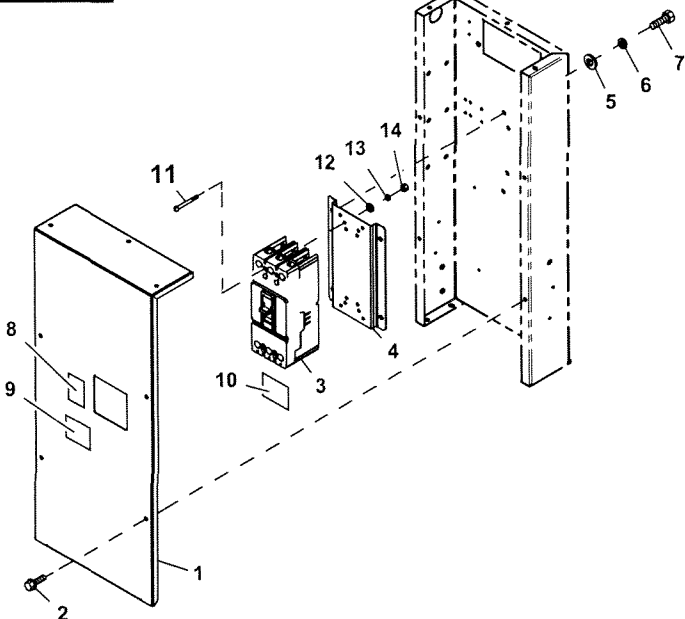

K-FRAME

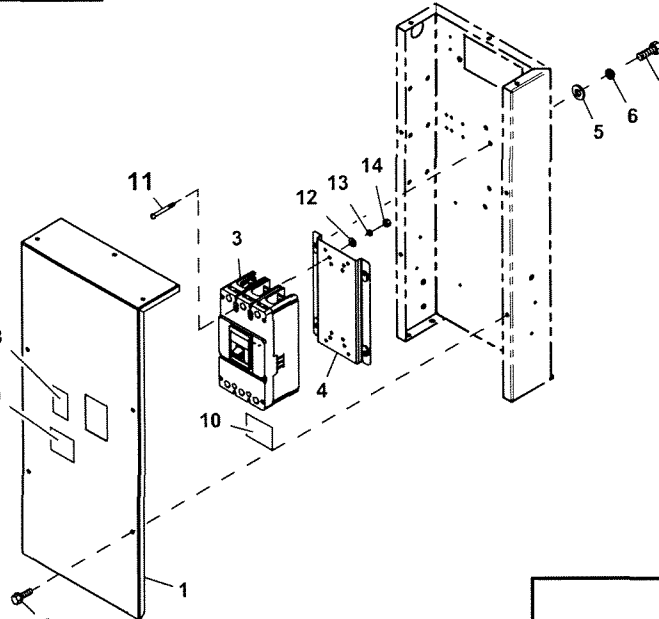

# GROUP H

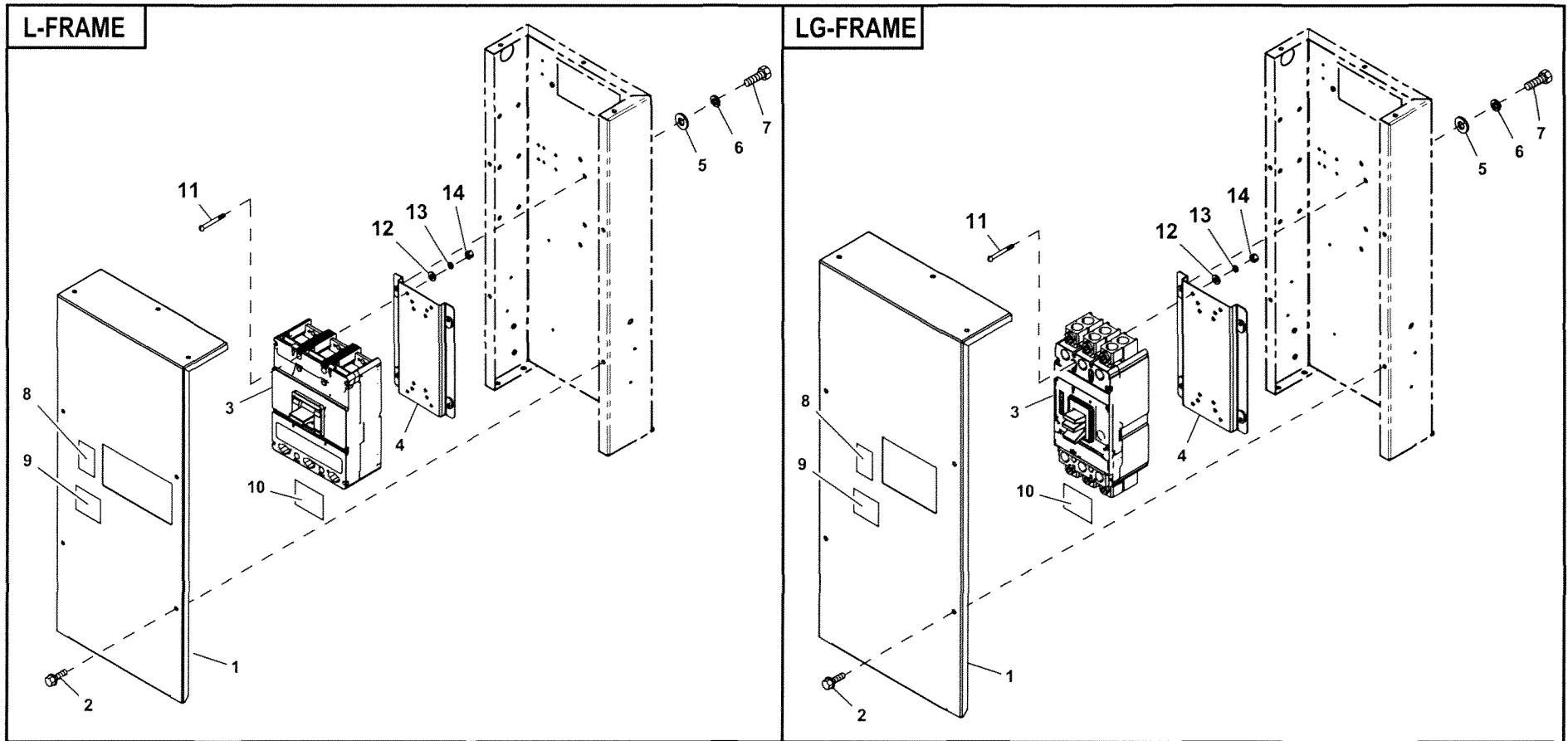

**EXPLODED VIEW: EV, CB MOUNTING KIT MD1 390**

**DRAWING #: 0J1027**

**GROUP H**

**APPLICABLE TO:**

ITEM	PART#	QTY.	DESCRIPTION
NO CIRCUIT BREAKERS			
(1)1	0H93780ST0R	1	MD1,MODULE COVER 390 G-FRAME
2	0C2454	9	SCREW HWHT M6-1 X 16 N WA Z/JS
3	0J0679	1	DECAL, CANADIAN SAFETY CODE
4	0J0546	1	DECAL, HV CUSTOMER CONN INSIDE
5	0D3719C	REF	DECAL, HV CUSTOMER CONN INSIDE
	0D3719D	REF	DECAL CUSTOMER CONN E1 E3
(1)6	0J34710ST0R	1	MD1-MD3 NO CB MNT BRACKET
7	0J3958	REF	CU BUSS BAR 1/4"X2.5" 625A
8	022145	4	WASHER FLAT 5/16-M8 ZINC
9	022129	4	WASHER LOCK M8-5/16
10	042907	4	SCREW HHC M8-1.25 X 16 C8.8
11	0C6937M	6	INSULATOR, STANDOFF 600V3/8-16
12	022241	6	NUT HEX 3/8-16 STEEL
13	022237	12	WASHER LOCK 3/8
14	022131	12	WASHER FLAT 3/8-M10 ZINC
15	032414	8	SCREW HHC 3/8-16 X 5/8 G5
16	090865	6	STUD 3/8-16 X 1.75 G5 STEEL
UL CIRCUIT BREAKER (225AF)			
(1)1	0H9378EST0R	1	MD1,MODULE COVER 390 GEN-225
2	0C2454	7	SCREW HWHT M6-1 X 16 N WA Z/JS
3	REF	1	CIRCUIT BREAKER
(1)4	0J14770ST0R	1	MD1, C/B MOUNTING BRACKET 225
5	022145	13	WASHER FLAT 5/16-M8 ZINC
6	022129	13	WASHER LOCK M8-5/16
7	042907	4	SCREW HHC M8-1.25 X 16 C8.8
8	0J0679	1	DECAL, CANADIAN SAFETY CODE
9	0J0546	1	DECAL, HV CUSTOMER CONN INSIDE
10	0D3719C	REF	DECAL CUSTOMER CONN E1 E2 E3
	0D3719D	REF	DECAL CUSTOMER CONN E1 E3
11	053640	4	SCREW RHM #8-32 X 3-1/4
12	038150	4	WASHER FLAT #8 ZINC
13	022264	4	WASHER LOCK #8-M4
14	022471	4	NUT HEX #8-32 STEEL
15	049897	6	SCREW SHC M8-1.25 X 20 G8
16	058306	3	SCREW SHC M8-1.25 X 25 C12.9
17	0F8451	3	LUG SLDLSS 300 MCM-6 AL/CU
18	0F8843	3	BUS BAR 200A LUG ADAPTOR
19	045771	3	NUT HEX M8-1.25 G8 CLEAR ZINC
20	0F8432	1	INSUL CB 225AF
UL CIRCUIT BREAKER (400AF)			
(1)1	0H9378JST0R	1	MD1,MODULE COVER 390 GEN-400
2	0C2454	7	SCREW HWHT M6-1 X 16 N WA Z/JS
3	REF	1	CIRCUIT BREAKER
(1)4	0J00680ST0R	1	MD2, C/B BACK MOUNTING BRACKET
5	022145	4	WASHER FLAT 5/16-M8 ZINC
6	022129	4	WASHER LOCK M8-5/16
7	042907	4	SCREW HHC M8-1.25 X 16 C8.8
8	0J0679	1	DECAL, CANADIAN SAFETY CODE
9	0J0546	1	DECAL, HV CUSTOMER CONN INSIDE
10	0D3719C	REF	DECAL CUSTOMER CONN E1 E2 E3
	0D3719D	REF	DECAL CUSTOMER CONN E1 E3
11	069232	4	SCREW RHM #10-32 X 3-3/4
12	023897	4	WASHER FLAT #10 ZINC
13	022152	4	WASHER LOCK #10
14	022158	4	NUT HEX #10-32 STEEL
15	052647	3	SCREW SHC M10-1.5 X 25 C12.9
16	046526	3	WASHER LOCK M10
17	0A7822	6	LUG SLDLSS 600/250-1/0X1/4-28
18	022473	12	WASHER FLAT 1/4-M6 ZINC
19	022097	12	WASHER LOCK M6-1/4
20	023334	12	SCREW HHC 1/4-28 X 1/2 G5
21	0J7188	3	BUS BAR ADAPTOR

**EXPLODED VIEW: EV, CB MOUNTING KIT MD1 390**

**DRAWING #: 0J1027**

**GROUP H**

**APPLICABLE TO:**

ITEM	PART#	QTY.	DESCRIPTION
UL CIRCUIT BREAKER (G-FRAME)			
(1)1	0H9378AST0R	1	MD1,MODULE COVER 390 G-FRAME
2	0C2454	7	SCREW HWHT M6-1 X 16 N WA Z/JS
3	REF	1	CIRCUIT BREAKER
(1)4	0J14880ST0R	1	MD1, C/B MOUNTING BRACKET G
5	022145	4	WASHER FLAT 5/16-M8 ZINC
6	022129	4	WASHER LOCK M8-5/16
7	042907	4	SCREW HHC M8-1.25 X 16 C8.8
8	0J0679	1	DECAL, CANADIAN SAFETY CODE
9	0J0546	1	DECAL, HV CUSTOMER CONN INSIDE
10	0D3719C	REF	DECAL CUSTOMER CONN E1 E2 E3
	0D3719D	REF	DECAL CUSTOMER CONN E1 E3
11	0J4465	4	SCREW SHC M4-0.7 X 80 C12.9
12	043180	4	WASHER FLAT M4
13	022264	4	WASHER LOCK #8-M4
14	051715	4	NUT HEX M4-0.7 G8 YEL CHR
UL CIRCUIT BREAKER (F -FRAME)			
(1)1	0H9378BST0R	1	MD1,MODULE COVER 390 F-FRAME
2	0C2454	7	SCREW HWHT M6-1 X 16 N WA Z/JS
3	REF	1	CIRCUIT BREAKER
(1)4	0J14860ST0R	1	MD1, C/B MOUNTING BRACKET F
5	022145	4	WASHER FLAT 5/16-M8 ZINC
6	022129	4	WASHER LOCK M8-5/16
7	042907	4	SCREW HHC M8-1.25 X 16 C8.8
8	0J0679	1	DECAL, CANADIAN SAFETY CODE
9	0J0546	1	DECAL, HV CUSTOMER CONN INSIDE
10	0D3719C	REF	DECAL CUSTOMER CONN E1 E2 E3
	0D3719D	REF	DECAL CUSTOMER CONN E1 E3
11	0J4899	4	SCREW SHC M4-0.7 X 45 C12.9
12	043180	4	WASHER FLAT M4
13	022264	4	WASHER LOCK #8-M4
14	051715	4	NUT HEX M4-0.7 G8 YEL CHR
UL CIRCUIT BREAKER (JG -FRAME)			
(1)1	0H9378DST0R	1	MD1,MODULE COVER 390 JG-FRAME
2	0C2454	7	SCREW HWHT M6-1 X 16 N WA Z/JS
3	REF	1	CIRCUIT BREAKER
(1)4	0J14860ST0R	1	MD1, C/B MOUNTING BRACKET F
5	022145	4	WASHER FLAT 5/16-M8 ZINC
6	022129	4	WASHER LOCK M8-5/16
7	042907	4	SCREW HHC M8-1.25 X 16 C8.8
8	0J0679	1	DECAL, CANADIAN SAFETY CODE
9	0J0546	1	DECAL, HV CUSTOMER CONN INSIDE
10	0D3719C	REF	DECAL CUSTOMER CONN E1 E2 E3
	0D3719D	REF	DECAL CUSTOMER CONN E1 E3
11	0J4466	4	SCREW SHC M4-0.7 X 100 C12.9
12	043180	4	WASHER FLAT M4
13	022264	4	WASHER LOCK #8-M4
14	051715	4	NUT HEX M4-0.7 G8 YEL CHR
UL CIRCUIT BREAKER (J -FRAME)			
(1)1	0H9378CST0R	1	MD1,MODULE COVER 390 J-FRAME
2	0C2454	7	SCREW HWHT M6-1 X 16 N WA Z/JS
3	REF	1	CIRCUIT BREAKER
(1)4	0J00680ST0R	1	MD2, C/B BACK MOUNTING BRACKET
5	022145	4	WASHER FLAT 5/16-M8 ZINC
6	022129	4	WASHER LOCK M8-5/16
7	042907	4	SCREW HHC M8-1.25 X 16 C8.8
8	0J0679	1	DECAL, CANADIAN SAFETY CODE
9	0J0546	1	DECAL, HV CUSTOMER CONN INSIDE
10	0D3719C	REF	DECAL CUSTOMER CONN E1 E2 E3
	0D3719D	REF	DECAL CUSTOMER CONN E1 E3
11	049967	4	SCREW SHC M6-1.0 X 70 C12.9
12	022473	4	WASHER FLAT 1/4-M6 ZINC
13	022097	4	WASHER LOCK M6-1/4
14	049813	4	NUT HEX M6-1.0 G8 CLEAR ZINC

**EXPLODED VIEW: EV, CB MOUNTING KIT MD1 390**

**DRAWING #: 0J1027**

**GROUP H**

**APPLICABLE TO:**

ITEM	PART#	QTY.	DESCRIPTION
UL CIRCUIT BREAKER (K -FRAME)			
(1)1	0H9378FST0R	1	MD1,MODULE COVER 390 K-FRAME
2	0C2454	7	SCREW HWHT M6-1 X 16 N WA Z/JS
3	REF	1	CIRCUIT BREAKER
(1)4	0J00680ST0R	1	MD2, C/B BACK MOUNTING BRACKET
5	022145	4	WASHER FLAT 5/16-M8 ZINC
6	022129	4	WASHER LOCK M8-5/16
7	042907	4	SCREW HHC M8-1.25 X 16 C8.8
8	0J0679	1	DECAL, CANADIAN SAFETY CODE
9	0J0546	1	DECAL, HV CUSTOMER CONN INSIDE
10	0D3719C	REF	DECAL CUSTOMER CONN E1 E2 E3
	0D3719D	REF	DECAL CUSTOMER CONN E1 E3
11	046580	4	SCREW SHC M6-1.0 X 45 C12.9
12	022473	4	WASHER FLAT 1/4-M6 ZINC
13	022097	4	WASHER LOCK M6-1/4
14	049813	4	NUT HEX M6-1.0 G8 CLEAR ZINC
UL CIRCUIT BREAKER (L -FRAME)			
(1)1	0H9378GST0R	1	MD1,MODULE COVER 390 L-FRAME
2	0C2454	7	SCREW HWHT M6-1 X 16 N WA Z/JS
3	REF	1	CIRCUIT BREAKER
(1)4	0J00680ST0R	1	MD2, C/B BACK MOUNTING BRACKET
5	022145	4	WASHER FLAT 5/16-M8 ZINC
6	022129	4	WASHER LOCK M8-5/16
7	042907	4	SCREW HHC M8-1.25 X 16 C8.8
8	0J0679	1	DECAL, CANADIAN SAFETY CODE
9	0J0546	1	DECAL, HV CUSTOMER CONN INSIDE
10	0D3719C	REF	DECAL CUSTOMER CONN E1 E2 E3
	0D3719D	REF	DECAL CUSTOMER CONN E1 E3
11	046580	4	SCREW SHC M6-1.0 X 45 C12.9
12	022473	4	WASHER FLAT 1/4-M6 ZINC
13	022097	4	WASHER LOCK M6-1/4
14	049813	4	NUT HEX M6-1.0 G8 CLEAR ZINC
UL CIRCUIT BREAKER (LG-FRAME)			
(1)1	0H9378HST0R	1	MD1,MODULE COVER 390 LG-FRAME
2	0C2454	7	SCREW HWHT M6-1 X 16 N WA Z/JS
3	REF	1	CIRCUIT BREAKER
(1)4	0J00680ST0R	1	MD2, C/B BACK MOUNTING BRACKET
5	022145	4	WASHER FLAT 5/16-M8 ZINC
6	022129	4	WASHER LOCK M8-5/16
7	042907	4	SCREW HHC M8-1.25 X 16 C8.8
8	0J0679	1	DECAL, CANADIAN SAFETY CODE
9	0J0546	1	DECAL, HV CUSTOMER CONN INSIDE
10	0D3719C	REF	DECAL CUSTOMER CONN E1 E2 E3
	0D3719D	REF	DECAL CUSTOMER CONN E1 E3
11	0J4467	4	SCREW SHC M5-0.8 X 100 C12.9
12	051713	4	WASHER FLAT M5
13	049226	4	WASHER LOCK M5
14	051716	4	NUT HEX M5-0.8 G8 CLEAR ZINC

NOTES (UNLESS OTHERWISE SPECIFIED):

(1) SHEET METAL PARTS LISTED IN THE BOM TABLE ARE REPRESENTING GENERIC PARTS (NO COLOR)

- MANUFACTURING: FOR CORRECT MATERIAL AND COLOR REFER TO AS400 BOM.
- CUSTOMER: WHEN ORDERING REPLACEMENT PARTS ENTER BASE NUMBER (FIRST 6 DIGITS ONLY) IN THE SYSTEM FOR CORRECT MATERIAL AND COLOR (FOR REFERENCE SEE GUIDELINE 0H7169).

# GROUP A

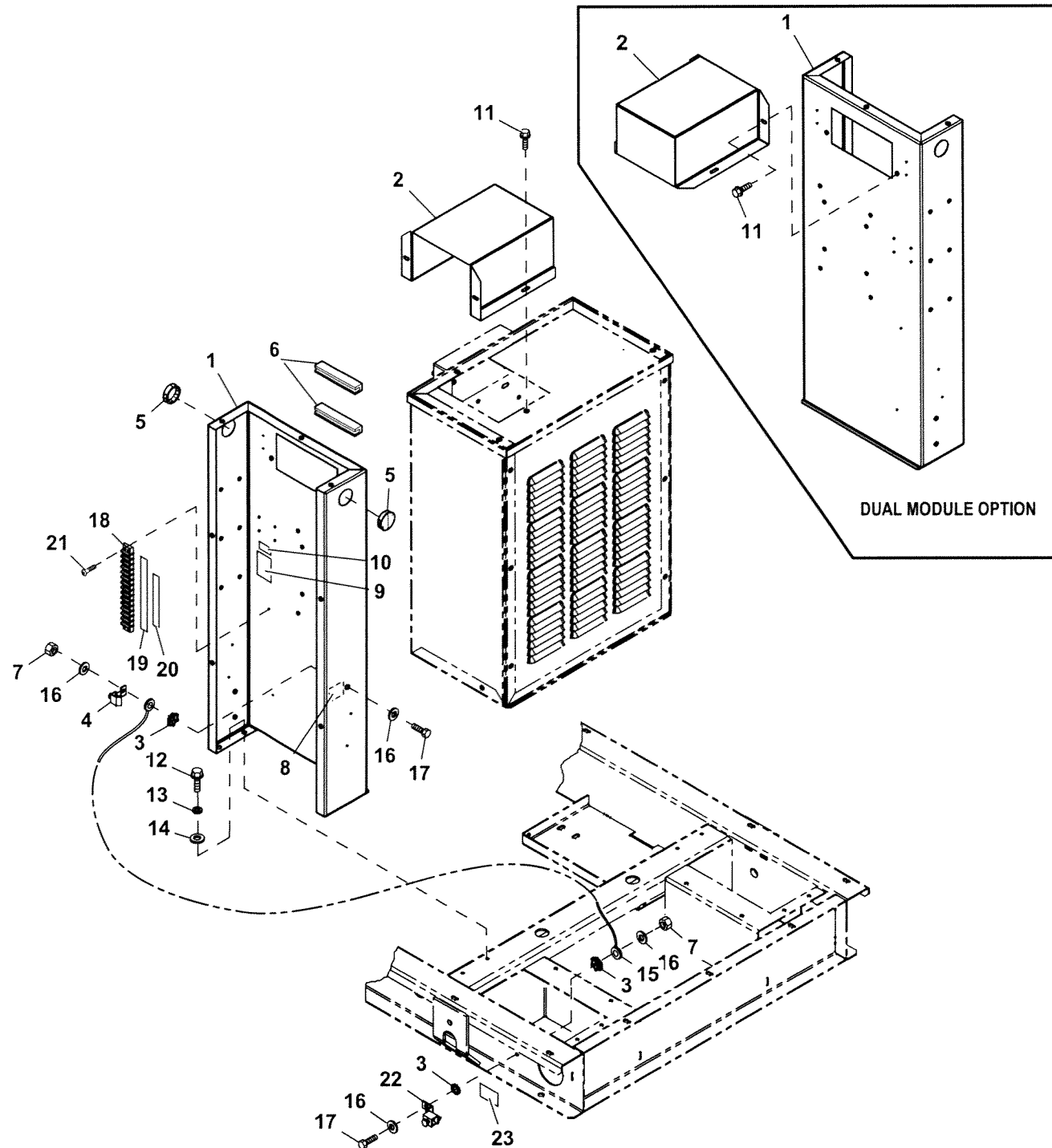



**EXPLODED VIEW: EV CONBOX 390 MODULE**

**DRAWING #: 0J1339**

**GROUP A**

**APPLICABLE TO:**

ITEM	PART#	QTY.	DESCRIPTION
(1)1	0H95790ST0R	1	MD1 / MD2 CB MODULE 390 ALT
(1)2	0J17560ST0R	1	WIRE TUNNEL, MD1-2 390 ALT
3	0A4456	3	WASHER LOCK SPECIAL 3/8
4	061383	1	LUG SLDLSS 3/0-#4 X 13/32 CU
5	0E1534A	2	PLUG PLASTIC 1.50"
6	056326	2	TRIM VINYL BLACK 1/8GP (7.1"LG)
7	045772	1	NUT HEX M10-1.5 G8 YEL CHR
8	067210A	1	DECAL GROUND LUG
9	0H8006	1	DECAL CAUTION ELEC SHOCK SM
10	0A9457	1	DECAL NEUTRAL
11	0C2454	4	SCREW HWHT M6-1 X 16 N WA Z/JS
12	024526	4	SCREW HHTT 5/16-18 X 3/4 CZ
13	022129	4	WASHER LOCK M8-5/16
14	022145	4	WASHER FLAT 5/16-M8 ZINC
15	0441140781	1	WIRE ASM, GND 2/0 WIRE 3/8 LUG
16	022131	4	WASHER FLAT 3/8-M10 ZINC
17	049541	2	SCREW HHC M10-1.5 X 35 C8.8
(3)(2)18	0J0455	REF	BLOCK, TERM 14 POS X 8 X 1600V
(3)(2)19	0J0394	REF	DECAL, TB4 HV CUSTOMER CONN
(3)(2)20	0J0574	REF	DECAL, CUSTOMER WIRE #10
(3)(2)21	0J5462	REF	SCREW THTT M4-0.7 X 16 ZP
22	061383	1	LUG SLDLSS 3/0-#4 X 13/32 CU
23	067210A	1	DECAL GROUND LUG

(1) SHEET METAL PARTS LISTED IN THE BOM TABLE ARE REPRESENTING GENERIC PARTS (NO COLOR).

- **MANUFACTURING:** FOR CORRECT MATERIAL AND COLOR REFER TO AS400 BOM.
- **CUSTOMER:** FOR CORRECT MATERIAL AND COLOR OF REPLACEMENT PARTS REFER TO "REPLACEMENT SHEET METAL PARTS ORDERING GUIDE-0H7169" INCLUDED IN THE MANUAL OR AVAILABLE ON THE GENERAC WEBSITE.

(2) WILL BE INSTALLED ON PRIMARY CB MODULES ONLY. NOT REQUIRED WITH LOAD CENTER.

(3) NOT REQUIRED IF EQUIPPED WITH LOAD CENTER.

# GROUP A

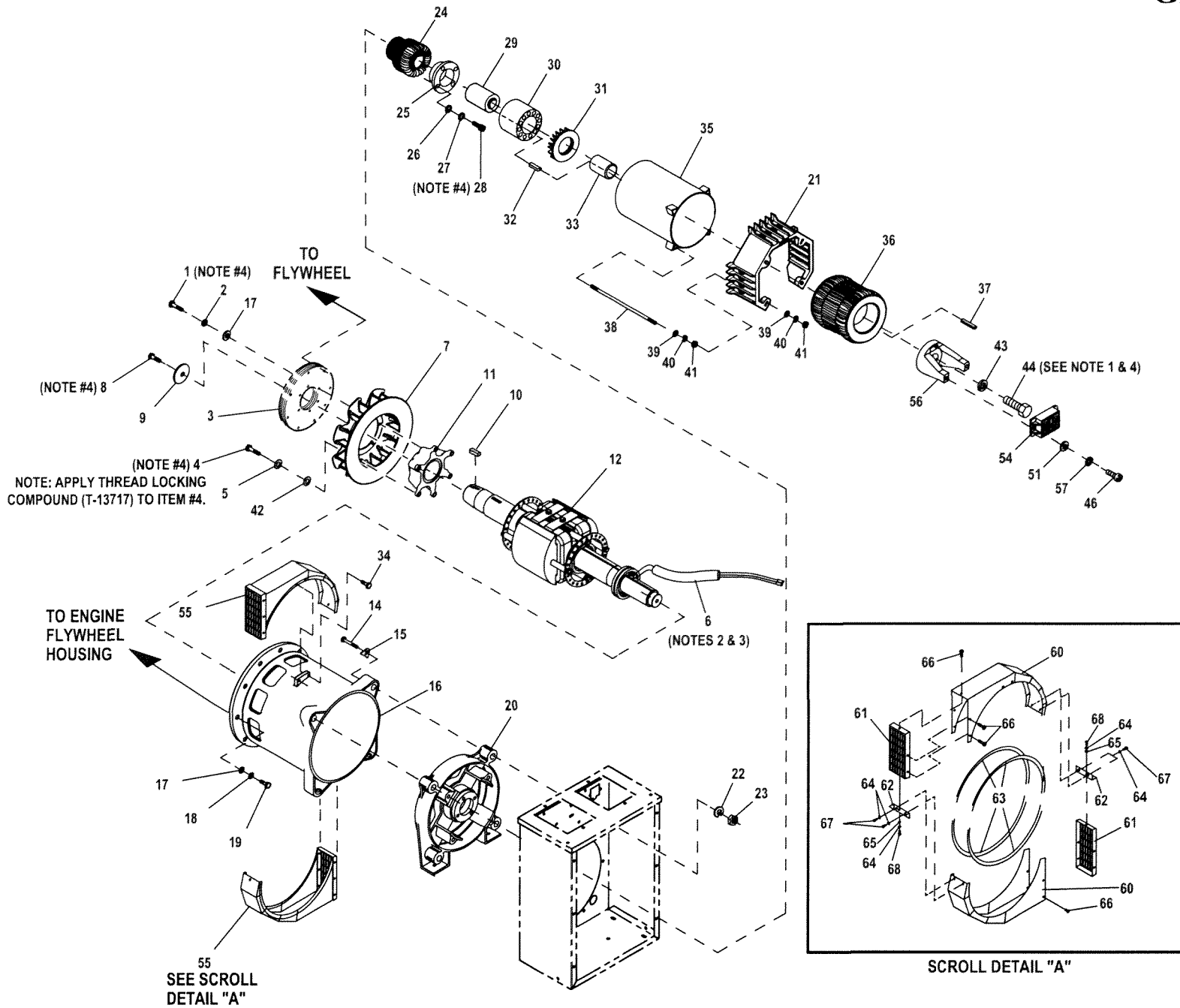

**EXPLODED VIEW: EV ALTCOMPRT <80KW DD PME G17**

**DRAWING #: 0J1481**

**GROUP A**

**APPLICABLE TO:**

ITEM	PART#	QTY.	DESCRIPTION
1	063837	6	SCREW HHC M12-1.75 X 30 C10.9
2	051769	6	WASHER LOCK M12
3	P/N VARIES	REF	FLEX PLATE
4	055173	6	SCREW HHC M8-1.25 X 20 G10.9
5	022129	6	WASHER LOCK M8-5/16
6	037554C	1	SLEEVING UL #2 .268ID 3"PRECUT
7	0G0724	1	FAN MACHINED 390 SAE ALTERATOR
8	0A2601	1	SCREW HHC M16-2 X 45 G8.8
9	0A2602	1	WASHER FLAT .688 ID X 3.25 OD
10	0A1138	1	KEY SQ 3/8 X 2-1/2 STEEL
11	021941	1	COUPLER 390 SAE
12	VARIES	REF	ROTOR PER ORDER (SEE BOM)
13	0A1786	.5CC	ADH LOCTITE #8931 AA W/S
14	0A5580	4	SCREW HHC M14-2.0 X 140 G8.8
15	0A1633	4	WASHER 390 SAE ALT.
16	VARIES	REF	STATOR PER ORDER (SEE BOM)
17	022131	18	WASHER FLAT M10-3/8 ZINC
18	046526	12	WASHER LOCK M10
19	057642	12	SCREW HHC M10-1.5 X 40 G8.8
20	097485	1	BEARING CARRIER 390 PMG REAR
21	0H8394	1	390, BOARD SOLID LEAD TERM PME
22	043123	4	WASHER LOCK M14
23	051779	4	NUT HEX M14-2
24	094511	1	ASSY STATOR PME
25	080934	1	RING PME STATOR RETAINING
26	022473	4	WASHER FLAT M6-1/4 ZINC
27	022097	4	WASHER LOCK M6-1/4
28	082460	4	SCREW SHC M6-1.0 X 65 G10.9
29	0H7626	1	COLLAR SLIP FIT 122.65MM
30	084828B	1	HOUSING 520 PME MAGNET
31	088367	1	FAN MAGNETIC HOUSING
32	042558	1	KEY SQ 3/8 X 1 STEEL
33	0H7625A	1	COLLAR SLIP FIT 71.12
	0H7625C	1	COLLAR SLIP FIT 90.17
34	0A2110	2	SCREW SWAGE 1/4-20 X 1/2 ZYC
35	0E8771	1	EXCITER FIELD 1.25" W/CAN 25KW-35KW
	0E8782	1	EXCITER FIELD 2.00" 40KW-125KW
36	087271	1	ASSEMBLY EXCITER 25KW-35KW
	087272	1	ASSEMBLY EXCITER 40KW-125KW
37	0G2829	1	KEY SQ 3/8 X 1-3/4 STEEL
	0A1138	1	KEY SQ 3/8 X 2-1/2 STEEL
38	04576100CN	4	STUD M10-1.5 X 280 G5 ZINC
39	022131	8	WASHER FLAT M10-3/8 ZINC
40	046526	8	WASHER LOCK M10
41	045772	8	NUT HEX M10-1.5
42	022145	6	WASHER FLAT 5/16-M8 ZINC
43	0H7393	1	M20 RIBBED LOCK WASHER
44	0F1965	1	SCREW HHC M20-1.5 X 55 C8.8
46	089520	2	SCREW PFILHM M4-0.7 X 16
51	043180	2	WASHER FLAT M4
54	090152	1	ASSEMBLY BRIDGE RECTIFIER
55	0A4089	1	ASSEMBLY SCROLL 390 SAE
56	0E9107	1	MOUNT RECTIFIER
57	023365	2	WASHER SHAKEPROOF INT #8

EXPLODED VIEW: EV ALTCOMPRT <80KW DD PME G17

DRAWING #: 0J1481

GROUP A

APPLICABLE TO:

ITEM	PART#	QTY.	DESCRIPTION
		KIT 0A4089 PARTS	
60	0A2491	2	SHROUD ALT SHEET METAL
61	0A2497	2	SCREEN SHROUD SAE
62	0A2496	2	BRACKET TENSIONER SAE SCROLL
63	056326	8.4 FT	TRIM VINYL BLACK 1/8 GP
64	022097	6	WASHER LOCK M6-1/4
65	022473	6	WASHER FLAT 1/4-M6 ZINC
66	0A2110	12	SCREW SWAGE 1/4-20 X 1/2 Z/YC
67	047411	4	SCREW HHC M6-1.0 X 16 G8.8
68	045757	2	SCREW HHC M6-1.0 X 25 G8.8

**EXPLODED VIEW: EV ALTCOMPRT <80KW DD PME G17**

**DRAWING #: 0J1481**

**GROUP A**

**APPLICABLE TO:**

**THIS PAGE LEFT INTENTIONALLY BLANK**

# GROUP A

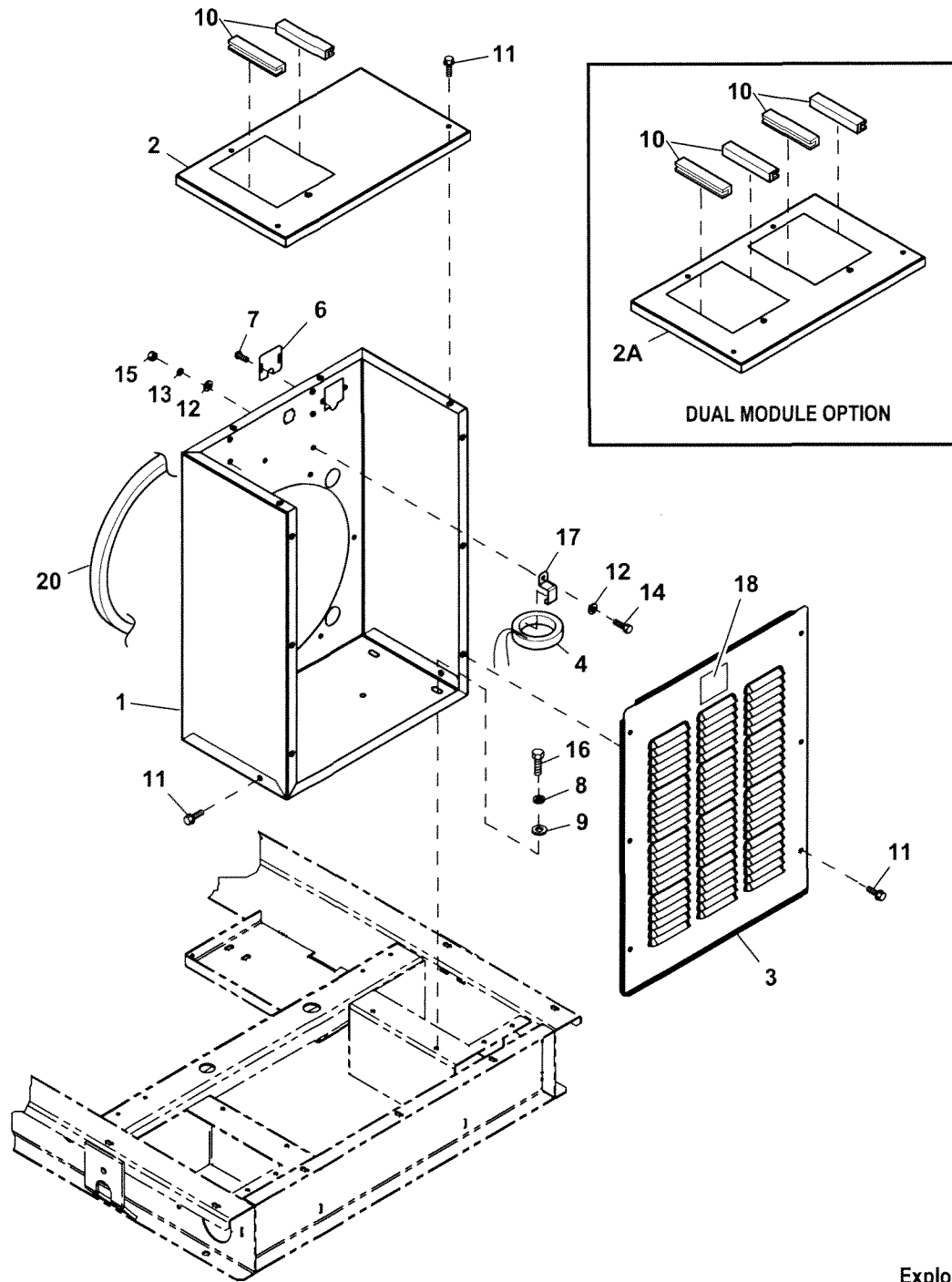

**EXPLODED VIEW: EV 390 ALTERNATOR TOWER ASM**

**DRAWING #: 0J1584**

**GROUP A**

**APPLICABLE TO:**

ITEM	PART#	QTY.	DESCRIPTION
(1)1	0H9429AST0R	1	MAIN, ALT TOWER 390 LONG
(1)2	0H94310ST0R	1	TOP, ALT TOWER 390 SINGLE CB
(1)2A	0H9431AST0R	1	TOP, ALT TOWER 390 DUAL CB
(1)3	0H94320ST0R	1	COVER, ALT TOWER 390
(3)4	0J0481	2/3	XFMR CURRENT 50A W/BRKT UL RCG
	0J0481A	2/3	XFMR CURRENT 100A W/BRKT UL G
	0J0481B	2/3	XFMR CURRENT 150A W/BRKT UL
	0J0481C	2/3	XFMR CURRENT 200A W/BRKT UL
	0J0481D	2/3	XFMR CURRENT 300A W/BRKT UL
	0J0481E	2/3	XFMR CURRENT 400A W/BRKT UL
	0J0481F	2/3	XFMR CURRENT 500A W/BRKT UL
	0J0481G	2/3	XFMR CURRENT 600A W/BRKT UL
5	N/A		
(1)6	0J01360ST0R	1	PLATE, WIRE HARN BLOCKOFF
7	0J5464	2	SCREW THTT M5-0.8 X 16 ZP
8	022097	4	WASHER LOCK M6-1/4
9	022473	4	WASHER FLAT 1/4-M6 ZINC
(2)10	056326	2/4	TRIM VINYL BLACK 1/8GP (6"LG)
11	0C2454	12	SCREW HWHT M6-1 X 16 N WA Z/JS
(3)12	022145	4/8	WASHER FLAT 5/16-M8 ZINC
(3)13	022129	2/3	WASHER LOCK M8-5/16
14	042907	2/3	SCREW HHC M8-1.25 X 16 C8.8
15	045771	2/3	NUT HEX M8-1.25 G8 CLEAR ZINC
16	024983	4	SCREW HHTT 1/4-20 X 3/4 CZ
(3)17	0J1857	2/3	CT BRKT 1.1" WINDOW FRAME
	0J1857A	2/3	CT BRKT 2.25" WINDOW FRAME
18	0C1229	1	DECAL WARNING ELECTRICAL SHOCK
19	0H9845	1	HARN 390/520 CONBOX H-PANEL (NOT SHOWN)
20	052250	1	TAPE FOAM 1X1 (49" LG)

NOTES (UNLESS OTHERWISE SPECIFIED):

- (1) SHEET METAL PARTS LISTED IN THE BOM TABLE ARE REPRESENTING GENERIC PARTS (NO COLOR)
  - MANUFACTURING: FOR CORRECT MATERIAL AND COLOR REFER TO AS400 BOM.
  - CUSTOMER: WHEN ORDERING REPLACEMENT PARTS ENTER BASE NUMBER (FIRST 6 DIGITS ONLY) IN THE SYSTEM FOR CORRECT MATERIAL AND COLOR (FOR REFERENCE SEE GUIDELINE 0H7169).
- (3) QTY. REQUIRED FOR 1 PHASE / QTY. REQUIRED FOR 3 PHASE.

# GROUP A

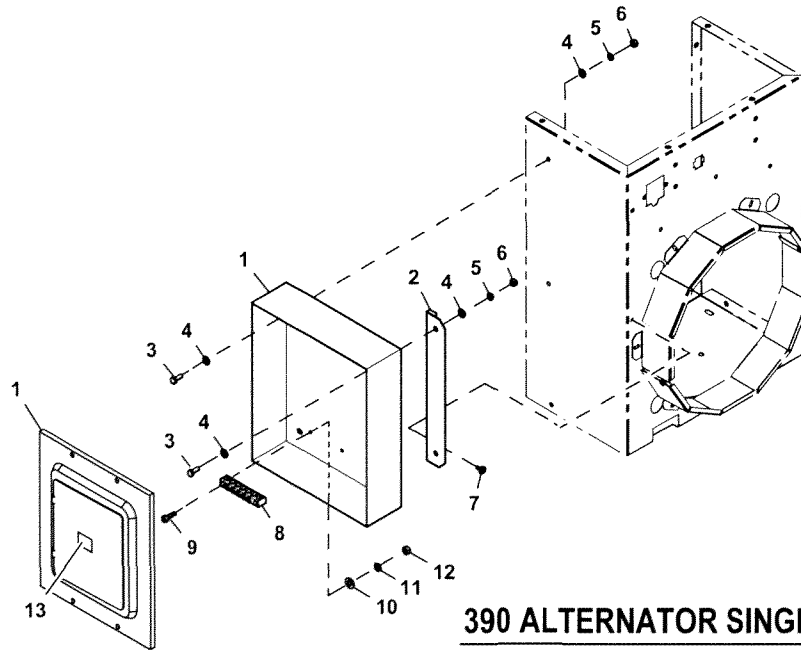

**390 ALTERNATOR SINGLE C/B**

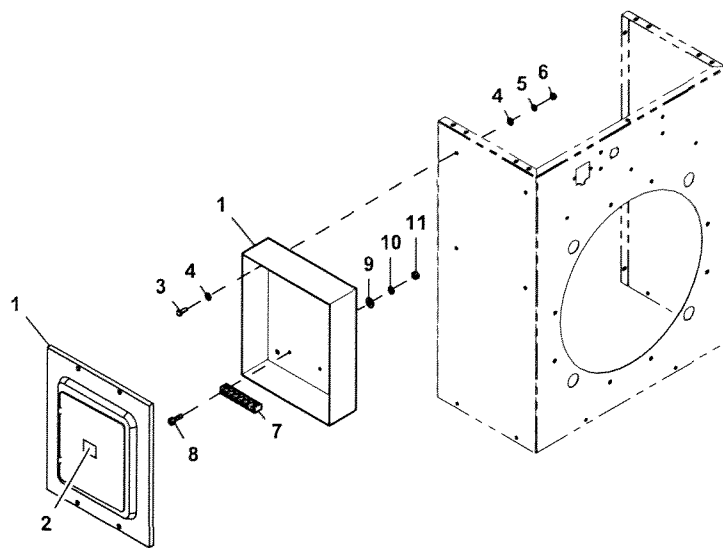

**520 ALTERNATOR SINGLE C/B**

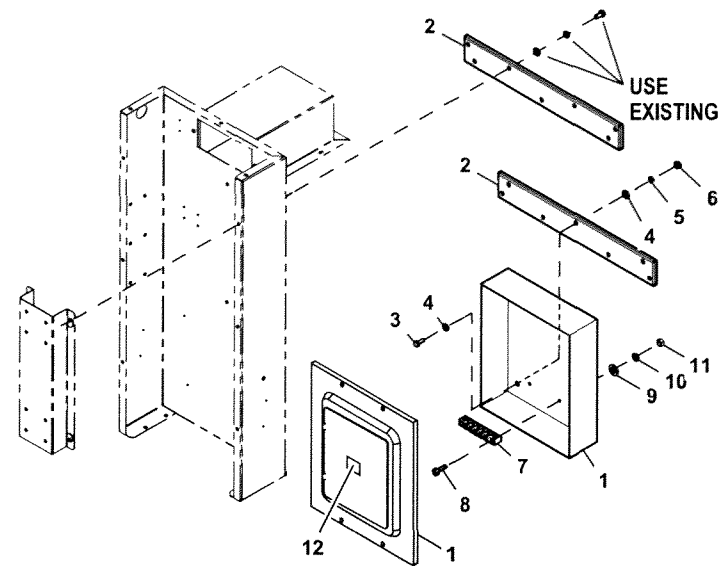

**390/520 ALTERNATOR DUAL C/B**



**EXPLODED VIEW: EV, LOAD CENTER KIT 390/520**

**DRAWING #: 0J5190**

**GROUP A**

**APPLICABLE TO:**

ITEM	PART#	QTY.	DESCRIPTION
390 ALTERNATOR SINGLE C/B			
1	0D8602	1	LOAD CENTER,125A,SIEMENS 8 BAY
	0D8602A	1	LOAD CTR,125A,SIEMENS NEMA 3R
(1)2	0J51820ST0R	1	390 ALT LOAD CENTER MOUNT
3	039253	4	SCREW HHC M8-1.25 X 20 C8.8
4	022145	8	WASHER FLAT 5/16-M8 ZINC
5	022129	4	WASHER LOCK M8-5/16
6	045771	4	NUT HEX M8-1.25 G8 CLEAR ZINC
7	0C2454	2	SCREW HWHT M6-1 X 16 N WA Z/JS
8	0E6523	1	GROUND BAR (5)4-14 AWG CONN
9	036920	2	SCREW PPHM #8-32 X 3/4
10	038150	2	WASHER FLAT #8 ZINC
11	022264	2	WASHER LOCK #8-M4
12	022471	2	NUT HEX #8-32 STEEL
13	0F1735	1	DECAL AUXILIARY LOAD PANEL
520 ALTERNATOR SINGLE C/B			
1	0D8602	1	LOAD CENTER,125A,SIEMENS 8 BAY
	0D8602A	1	LOAD CTR,125A,SIEMENS NEMA 3R
	0F1735	1	DECAL AUXILIARY LOAD PANEL
3	039253	4	SCREW HHC M8-1.25 X 20 C8.8
4	022145	8	WASHER FLAT 5/16-M8 ZINC
5	022129	4	WASHER LOCK M8-5/16
6	045771	4	NUT HEX M8-1.25 G8 CLEAR ZINC
7	0E6523	1	GROUND BAR (5)4-14 AWG CONN
8	036920	2	SCREW PPHM #8-32 X 3/4
9	038150	2	WASHER FLAT #8 ZINC
10	022264	2	WASHER LOCK #8-M4
11	022471	2	NUT HEX #8-32 STEEL
390/520 ALTERNATOR DUAL C/B			
1	0D8602	1	LOAD CENTER,125A,SIEMENS 8 BAY
	0D8602A	1	LOAD CTR,125A,SIEMENS NEMA 3R
(1)2	0J27960ST0R	2	BRACKET, LOAD CENTER DUAL MOD
3	039253	4	SCREW HHC M8-1.25 X 20 C8.8
4	022145	8	WASHER FLAT 5/16-M8 ZINC
5	022129	4	WASHER LOCK M8-5/16
6	045771	4	NUT HEX M8-1.25 G8 CLEAR ZINC
7	0E6523	1	GROUND BAR (5)4-14 AWG CONN
8	036920	2	SCREW PPHM #8-32 X 3/4
9	038150	2	WASHER FLAT #8 ZINC
10	022264	2	WASHER LOCK #8-M4
11	022471	2	NUT HEX #8-32 STEEL
12	0F1735	1	DECAL AUXILIARY LOAD PANEL

**NOTES (UNLESS OTHERWISE SPECIFEID):**

(1) SHEET METAL PARTS LISTED IN THE BOM TABLE ARE REPRESENTING GENERIC PARTS (NO COLOR)

- MANUFACTURING: FOR CORRECT MATERIAL AND COLOR REFER TO AS400 BOM.
- CUSTOMER: WHEN ORDERING REPLACEMENT PARTS ENTER BASE NUMBER (FIRST 6 DIGITS ONLY) IN THE SYSTEM FOR CORRECT MATERIAL AND COLOR (FOR REFERENCE SEE GUIDELINE 0H7169).

EXPLODED VIEW: TABLE H-100 FIELD RES & DPE CB

DRAWING #: 0F9280

GROUP B

APPLICABLE TO:

DPE Breaker and Field Boost Resistor Table for Gensets with H-Panel Control & 12V Battery								
VOLTAGE	FREQUENCY	EXCITATION	SIZE	KW RATING	DPE BREAKER		FIELD BOOST RESISTOR	
					PART NO.	SIZE	PART NO.	SIZE
120/240 1φ	60 Hz	direct	390 mm or smaller	1kW - 8.9kW	048512	5A	0F5752E	5 ohm
		PME/brushless		9kW - 45kW	048467	7A		
				1kW - 15kW	053623	2.5A		
				16kW - 18kW	049350	4A		
				19kW - 26kW	054450	5.5A		
				27kW - 41kW	048505	6A		
				45kW - 130kW	048476	4.5A		
520 mm	any	048476	4.5A	0F5752D	75 ohm			
120/208 3φ	60 Hz	direct	390 mm or smaller	1kW - 8.9kW	048512	5A	0F5752E	5 ohm
		PME/brushless		9kW - 45kW	048467	7A		
				1kW - 15kW	053623	2.5A		
				16kW - 18kW	049350	4A		
				19kW - 26kW	054450	5.5A		
				27kW - 41kW	048505	6A		
				45kW - 130kW	048476	4.5A		
520 mm	any	048476	4.5A	0F5752D	75 ohm			
120/240 3φ	60 Hz	direct	390 mm or smaller	1kW - 8.9kW	048512	5A	0F5752E	5 ohm
		PME/brushless		9kW - 45kW	048467	7A		
				1kW - 15kW	053623	2.5A		
				16kW - 18kW	049350	4A		
				19kW - 26kW	054450	5.5A		
				27kW - 41kW	048505	6A		
				45kW - 130kW	048476	4.5A		
520 mm	any	048476	4.5A	0F5752D	75 ohm			
277/480 3φ	60 Hz	direct	390 mm or smaller	1kW - 8.9kW	048512	5A	0F5752E	5 ohm
		PME/brushless		9kW - 45kW	048467	7A		
				1kW - 15kW	053623	2.5A		
				16kW - 26kW	054450	5.5A		
				27kW - 41kW	048505	6A		
				45kW - 130kW	048476	4.5A		
				520 mm	any	048476		
346/600 3φ	60 Hz	direct	390 mm or smaller	1kW - 8.9kW	048512	5A	0F5752E	5 ohm
		PME/brushless		9kW - 45kW	048467	7A		
				1kW - 15kW	053623	2.5A		
				16kW - 18kW	049350	4A		
				19kW - 26kW	054450	5.5A		
				27kW - 130kW	048476	4.5A		
				520 mm	any	048476		
110/220 1φ	50 Hz	direct	390 mm or smaller	1kW - 8.9kW	048512	5A	0F5752E	5 ohm
		PME/brushless		9kW - 45kW	048467	7A		
				1kW - 15kW	053623	2.5A		
				16kW - 18kW	049350	4A		
				19kW - 26kW	048476	4.5A		
				27kW - 130kW	048505	6A		
				520 mm	any	048476		
100/200 3φ	50 Hz	direct	390 mm or smaller	1kW - 8.9kW	048512	5A	0F5752E	5 ohm
		PME/brushless		9kW - 45kW	048467	7A		
				1kW - 15kW	053623	2.5A		
				16kW - 18kW	049350	4A		
				19kW - 26kW	048476	4.5A		
				27kW - 130kW	048505	6A		
				520 mm	any	048476		
115/200 3φ	50 Hz	direct	390 mm or smaller	1kW - 8.9kW	048512	5A	0F5752E	5 ohm
		PME/brushless		9kW - 45kW	048467	7A		
				1kW - 15kW	053623	2.5A		
				16kW - 18kW	049350	4A		
				19kW - 26kW	048476	4.5A		
				27kW - 130kW	048505	6A		
				520 mm	any	048476		
231/400 3φ	50 Hz	direct	390 mm or smaller	1kW - 8.9kW	048512	5A	0F5752E	5 ohm
		PME/brushless		9kW - 45kW	048467	7A		
				1kW - 15kW	053623	2.5A		
				16kW - 18kW	049350	4A		
				19kW - 26kW	054450	5.5A		
				27kW - 41kW	048505	6A		
				45kW - 130kW	048476	4.5A		
520 mm	any	048476	4.5A	0F5752D	75 ohm			

EXPLODED VIEW: TABLE H-100 FIELD RES & DPE CB

DRAWING #: 0F9280

APPLICABLE TO:

GROUP B

**BLANK  
PAGE**

# GROUP B

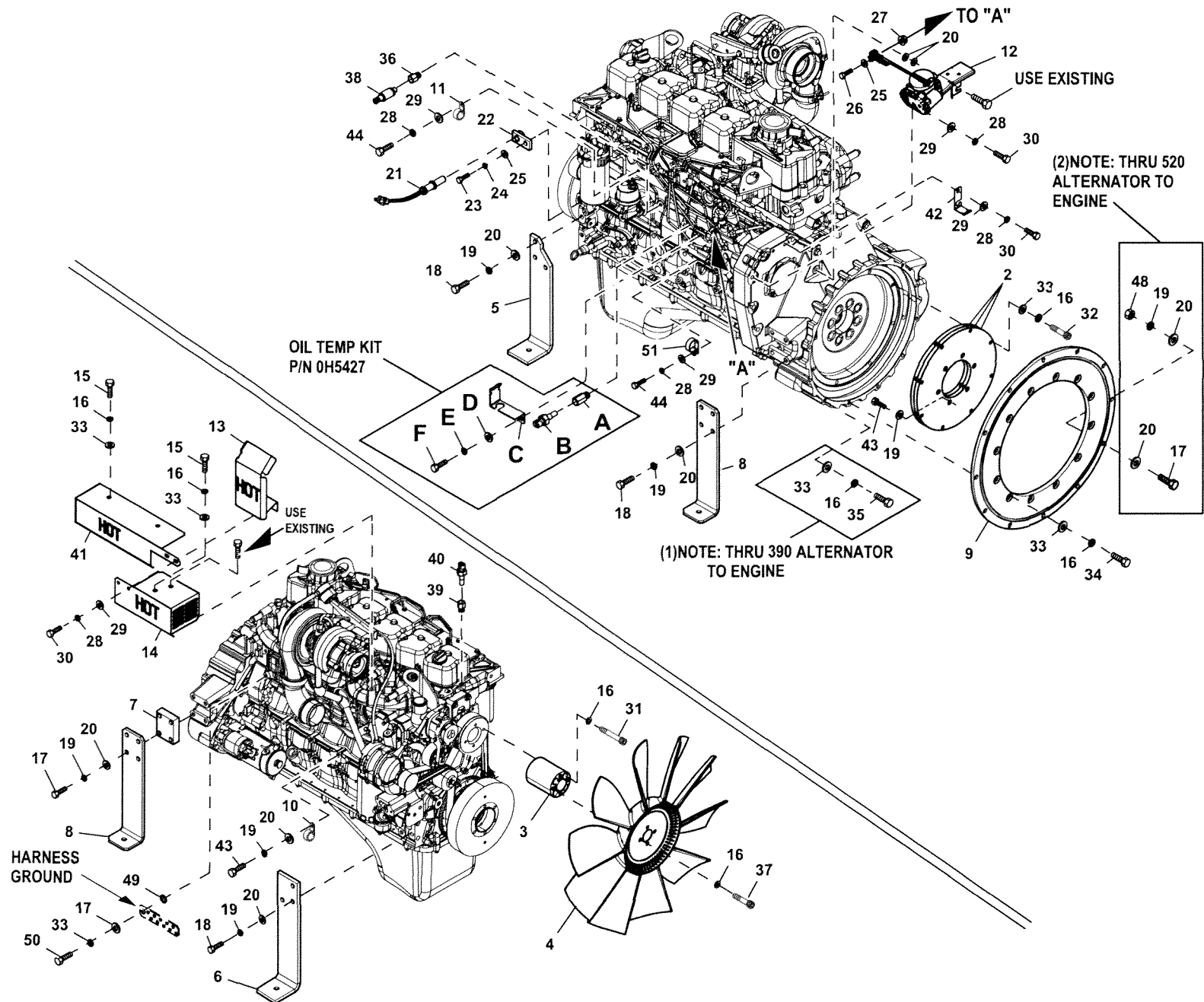

**EXPLODED VIEW: EV ENGCOMPRT 6.7L LO G17**

**DRAWING #: 0H2124**

**GROUP B**

**APPLICABLE TO:**

ITEM	PART#	QTY.	DESCRIPTION
1	0J2730	REF	ENGINE D6.7L G17 100/130KW
(2)2	021322A	5	FLEX PLATE, 520 ALT
	(1) 020604	3	PLATE FLEX 11-1/2 SAE 390
3	0H2119A	1	FAN SPACER 6.7L G17
4	0F2610	1	FAN COOL 26" LH ROTATION
5	0H21450ST03	1	FOOT ENGINE LF D6.7L G17
6	0H21460ST03	1	FOOT ENGINE RF D6.7L G17
7	0H3201	1	ENGINE FOOT SPACER
8	0H22980ST03	2	REAR ENGINE FEET 4.5L G17
(2)9	021325	1	ADAPTER SAE3X520 ALT (MACHD)
(4)10	055934P	1	CLAMP STL/VNL 1.62 X .486
(3)11	055934M	1	CLAMP STL/VNL .75 X .343 Z
12	0H5182A	1	ASSY. MECH BOSCH ACTUATOR
(5)13	0H51420SS0R	1	HEAT SHEILD TURBO 6.7L LO G17
(50)14	0H51410SS0R	1	HEAT SHEILD 6.7L 100-130KW G17
15	051756	4	SCREW HHC M10-1.5 X 20 C8.8
16	046526	27	WASHER LOCK M10
17	081816	16	SCREW HHC M12-1.75 X 55 C10.9
18	063837	10	SCREW HHC M12-1.75 X 30 C10.9
19	051769	34	WASHER LOCK M12
20	049808	43	WASHER FLAT M12
21	0D2244M	1	ASSY MAGPICKUP(3/8-24 MALE)
22	0H5002	1	ADAPTER MAG PICKUP 6.7L LO G17
23	045757	1	SCREW HHC M6-1.0 X 25 C8.8
24	022097	1	WASHER LOCK M6-1/4
25	022473	2	WASHER FLAT 1/4-M6 ZINC
26	043116	1	SCREW HHC M6-1.0 X 12 G8.8
27	052857	1	NUT TOP LOCK FL M6-1.0
28	022129	5	WASHER LOCK M8-5/16
29	022145	5	WASHER FLAT 5/16-M8 ZINC
30	042907	4	SCREW HHC M8-1.25 X 16 C8.8
31	090502	4	SCREW SHC M10-1.5 X 60 C12.9
32	0J4574	8	SCREW SHC M10-1.5 X 25 C8.8
33	022131	21	WASHER FLAT 3/8-M10 ZINC
(2)34	052647	12	SCREW SHC M10-1.5 X 25 C12.9
(1)35	057642	12	SCREW HHC M10-1.5 X 40 C8.8
36	0A4707A	1	ADPATER 1/8NPT X M10-1.0
37	052648	4	SCREW SHC M10-1.5 X 20 C12.9
38	0F4612	1	SENDER OIL PRESSURE 1/8"NPT
39	030418	1	BSHG RDCR HEX 1/2 TO 3/8
40	0E0502	1	TEMPERATURE SENDER, DELPHI
(5)41	0H61800SS0R	1	HEAT SHEILD 6.7LG17 100/130 LH
42	0F2776	1	BRACKET, SIGNAL CONDITIONER
43	051768	7	SCREW HHC M12-1.75 X 25 C8.8
44	039253	2	SCREW HHC M8-1.25 X 20 C8.8
45	055934B	1	CLAMP STL/VNL 1 X .281 Z (NOT SHOWN)
46	086292	1	SCREW HWHSD #10-16 X 3/4 SEMS (NOT SHOWN)
47	0H4195	1	HARN ENG D4.5L/D6.7L G17 H-PNL (NOT SHOWN)
(2)48	045773	12	NUT HEX M12-1.75 G8 YEL CHR
49	025507	1	WASHER LOCK EXT 7/16 STL

**EXPLODED VIEW: EV ENGCOMPRT 6.7L LO G17**

**DRAWING #: 0H2124**

**GROUP B**

**APPLICABLE TO:**

ITEM	PART#	QTY.	DESCRIPTION
50	049814	1	SCREW HHC M10-1.5 X 25 C8.8
51	055934M	1	CLAMP STL/VNL .75 X .343 Z
	OIL TEMP KIT P/N 0H5427		
A	0A4707L	1	ADAPTER 3/8NPT X M14-1.5
B	0E0502	1	TEMPERATURE SENDER, DELPHI
C	0F2776A	1	BRACKET, SIGNAL CONDITIONER
D	022145	1	WASHER FLAT 5/16-M8 ZINC
E	022129	1	WASHER LOCK M8-5/16
F	042907	1	SCREW HHC M8-1.25 X 16 C8.8
G	0G0349	1	HARN OIL TEMP SENDER OPTION

(1) W / 390 ALTERNATOR ONLY

(2) W / 520 ALTERNATOR ONLY

(3) FOR ENGINE HARNESS

(4) FOR BLOCK HEATER

(5) SHEET METAL PARTS LISTED IN THE BOM TABLE ARE REPRESENTING GENERIC PARTS (NO COLOR).

- **MANUFACTURING:** FOR CORRECT MATERIAL AND COLOR REFER TO AS400 BOM.
- **CUSTOMER:** FOR CORRECT MATERIAL AND COLOR OF REPLACEMENT PARTS REFER TO "REPLACEMENT SHEET METAL PARTS ORDERING GUIDE-0H7169" INCLUDED IN THE MANUAL OR AVAILABLE ON THE GENERAC WEBSITE.

**EXPLODED VIEW: EV ENGCOMPRT 6.7L LO G17**

**DRAWING #: 0H2124**

**APPLICABLE TO:**

**GROUP B**

**THIS PAGE LEFT INTENTIONALLY BLANK**

# GROUP B

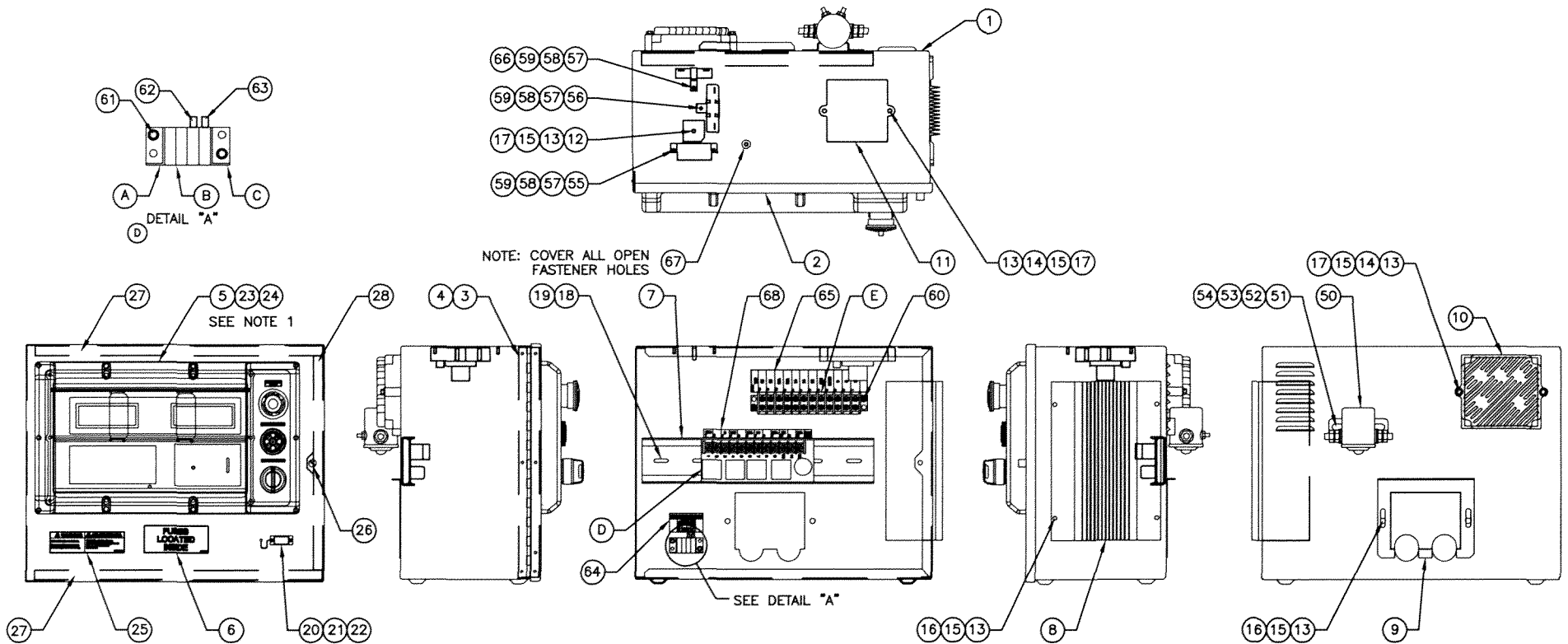

NOTE 1: ITEM 29 ATTACHES TO CONTACT ON REAR OF ITEM 5



EXPLODED VIEW: H-PANEL 10A BATTERY CHARGER E-GOV DIESEL 12V

DRAWING #: 0H5043D

GROUP B

APPLICABLE TO:

ITEM	PART #	QTY	DESCRIPTION
COMPONENTS INCLUDED IN 0G4140E			
1	0F1823CST03	1	ENCL H/G CONTROL PANEL
2	0F1824AST03	1	COVER CONTROL PANEL
3	0F2606	1	HINGE CONTINUOUS H-PANEL
4	036261	7	RIVET POP .125 X .275 SS
5	0F5763	1	ASSY PROGRAMMED H-100
6	0F1732	1	DECAL FUSES LOCATED INSIDE
7	0E9764	1 FT.	RAIL SNAPTRACK PCB HOLDER BULK
8	0F1740C	1	ASSY PCB 10A UL BATT CHRGR 12V
9	0F1958	1	PLATE HARNESS CLAMP
10	0F2256	1	ASSY PCB PWR AVR WIAMP HEADER
11	0E3161	1	ASSY PCB BOSCH GOV DRIVER
12	029673	1	DIO BRIDGE 25A 600V
13	049226	11	WASHER LOCK M5
14	079224	4	SCREW PPHM M5-0.8 X 30 SS
15	051713	11	WASHER FLAT M5
16	0F5886	6	SCREW HHPM M5-0.8 X 12
17	051716	5	NUT HEX M5-0.8 G8 YEL CHR
18	043180	3	WASHER FLAT M4
19	0C3990	3	SCREW PHTT M4-0.7 X 10 ZYC
20	0F4333	1	CONN DUST CAP W/CHAIN DB9
21	0F5883	1	WASHER FLAT M3.5
22	0F5884	1	SCREW PHTT M3.5-0.6 X 10
23	055014	10	SCREW PPHM M4-0.7 X 8 BLK OX
24	022264	10	WASHER LOCK #8-M4
25	0G3546	1	DECAL WRN BATT CHRGR 12/24V BI
26	0G3648	1	M5-0.8 CAPTIVE PANEL KNLD HD
27	0F6305	1	SEAL COVER 3.18 X 12.7 X 382
28	0F6305A	1	SEAL COVER 3.18 X 12.7 X 283
29	0G4329	1	HARNESS H-PNL INTEGRATED SW (NOT SHOWN)
COMPONENTS INCLUDED IN WIRE HARNESS			
A	0F1263	1	ADPTR RH SIDE WICKMANN 178.6191
B	0F1262	4	HOLDER FUSE WICKMANN 178.6150
C	0F1264	1	ADPTR LH SIDE WICKMANN 178.6192
D	0E9049B	1	ASSY PCB G-PANEL RELAY 12VDC
E	055911	1	BLOCK TERM 20A 12 X 6 X 1100V

ITEM	PART #	QTY	DESCRIPTION
COMPONENTS NOT INCLUDED IN 0G4140E OR WIRE HARNESS			
50	056739	1	RELAY CONTACTOR 12VDC
51	022287	2	SCREW HHC 1/4-20 X 3/4 G5
52	022473	4	WASHER FLAT M6 - 1/4
53	022097	2	WASHER LOCK M6 - 1/4
54	022127	2	NUT HEX 1/4-20 STEEL
55	-	REF.	DPE BREAKER SEE DRAWING 0F9280
56	-	REF.	BOOST RESISTOR SEE DRAWING 0F9280
57	043182	4	WASHER LOCK M3
58	051714	4	NUT HEX M3-0.5 G8 YEL CHR
59	052777	4	WASHER FLAT M3
60	0C2323	2	SCREW PHTT #6-32 X 5/8 ZYC
61	0C2699	2	SCREW PHTT #6-32 X 3/8 ZYC
62	0E7403B	1	FUSE ATO TYPE 10 AMP (RED)
63	0E7403C	1	FUSE ATO TYPE 15 AMP (BLUE)
64	0J7646	1	DECAL CONTROL BOX FUSES
65	0F5461	1	DECAL CPL 5.4/6.8L TB3
66	0F5752A	1	RES WW 10R 5% 15W QK CONN
67	0F6145	A/R	SEAL WEATHER .45" DIA
68	0F7473	1	DECAL H-100 RELAY BD 12V RB1

# GROUP H

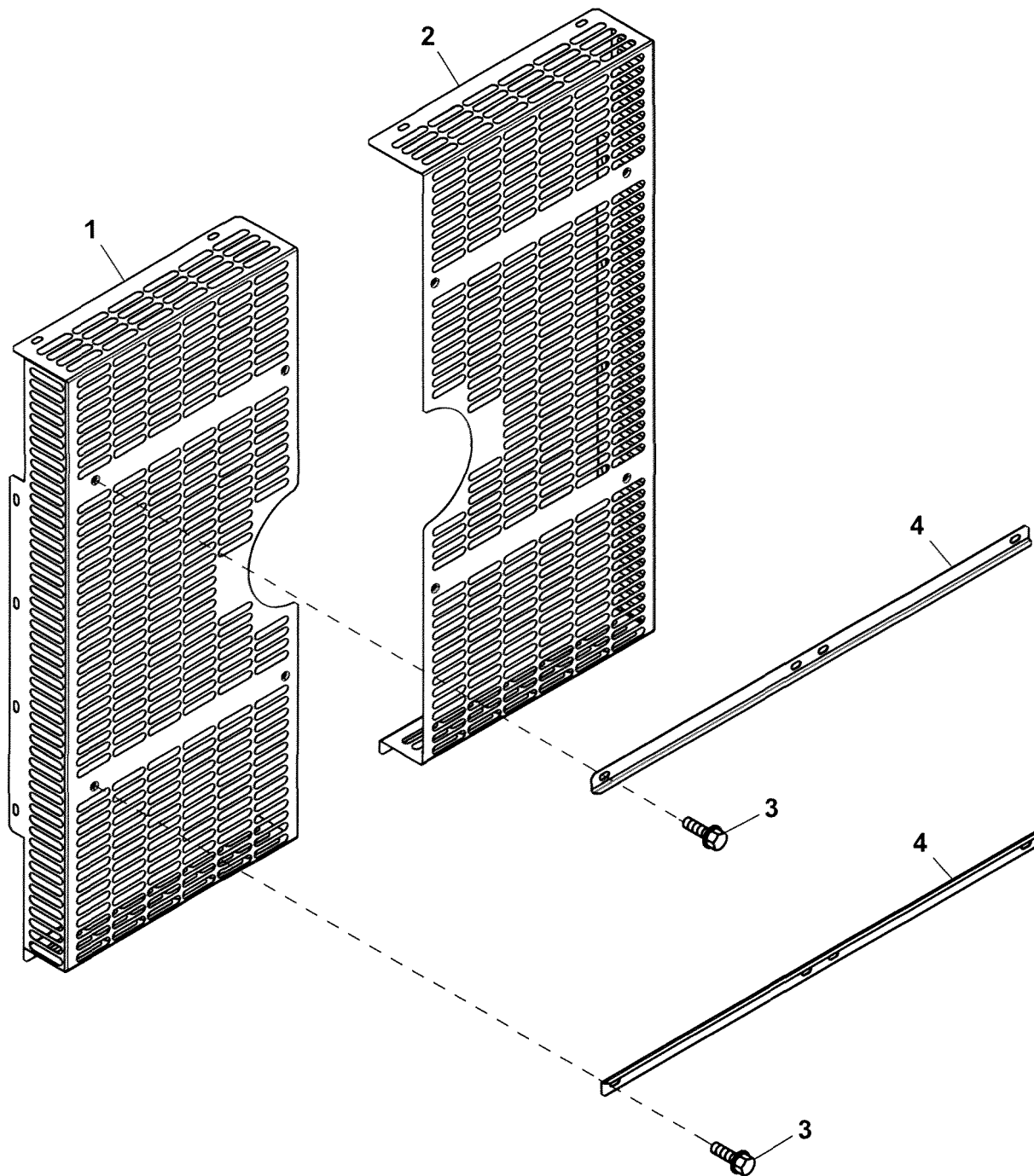

# GROUP B

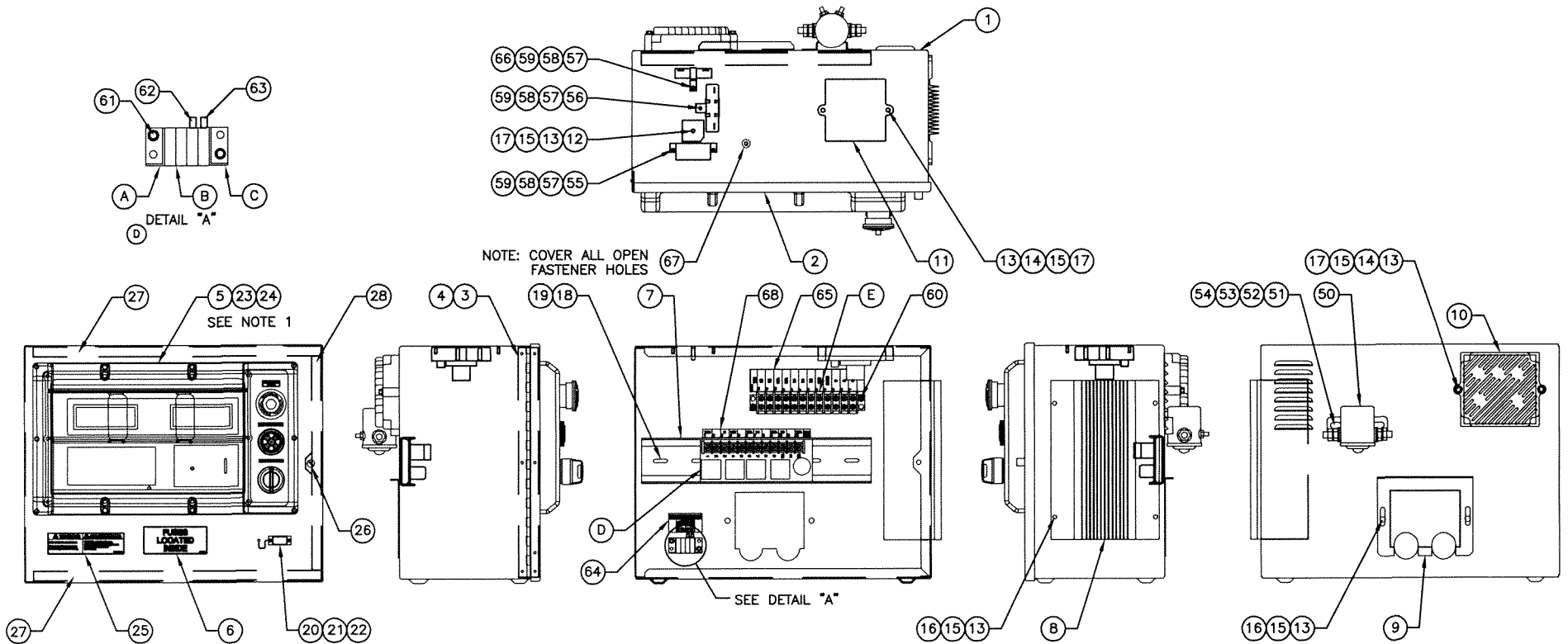

NOTE 1: ITEM 29 ATTACHES TO CONTACT ON REAR OF ITEM 5

EXPLODED VIEW: H-PANEL 10A BATTERY CHARGER E-GOV DIESEL 12V

DRAWING #: 0H5043D

GROUP B

APPLICABLE TO:

ITEM	PART #	QTY	DESCRIPTION
COMPONENTS INCLUDED IN 0G4140E			
1	0F1823CST03	1	ENCL H/G CONTROL PANEL
2	0F1824AST03	1	COVER CONTROL PANEL
3	0F2606	1	HINGE CONTINUOUS H-PANEL
4	036261	7	RIVET POP .125 X .275 SS
5	0F5763	1	ASSY PROGRAMMED H-100
6	0F1732	1	DECAL FUSES LOCATED INSIDE
7	0E9764	1 FT.	RAIL SNAPTRACK PCB HOLDER BULK
8	0F1740C	1	ASSY PCB 10A UL BATT CHRGR 12V
9	0F1958	1	PLATE HARNESS CLAMP
10	0F2256	1	ASSY PCB PWR AVR W/AMP HEADER
11	0E3161	1	ASSY PCB BOSCH GOV DRIVER
12	029673	1	DIO BRIDGE 25A 600V
13	049226	11	WASHER LOCK M5
14	079224	4	SCREW PPHM M5-0.8 X 30 SS
15	051713	11	WASHER FLAT M5
16	0F5886	6	SCREW HHPM M5-0.8 X 12
17	051716	5	NUT HEX M5-0.8 G8 YEL CHR
18	043180	3	WASHER FLAT M4
19	0C3990	3	SCREW PHTT M4-0.7 X 10 ZYC
20	0F4333	1	CONN DUST CAP W/CHAIN DB9
21	0F5883	1	WASHER FLAT M3.5
22	0F5884	1	SCREW PHTT M3.5-0.6 X 10
23	055014	10	SCREW PPHM M4-0.7 X 8 BLK OX
24	022264	10	WASHER LOCK #8-M4
25	0G3546	1	DECAL WRN BATT CHRGR 12/24V BI
26	0G3648	1	M5-0.8 CAPTIVE PANEL KNLD HD
27	0F6305	1	SEAL COVER 3.18 X 12.7 X 382
28	0F6305A	1	SEAL COVER 3.18 X 12.7 X 283
29	0G4329	1	HARNESS H-PNL INTEGRATED SW (NOT SHOWN)
COMPONENTS INCLUDED IN WIRE HARNESS			
A	0F1263	1	ADPTR RH SIDE WICKMANN 178.6191
B	0F1262	4	HOLDER FUSE WICKMANN 178.6150
C	0F1264	1	ADPTR LH SIDE WICKMANN 178.6192
D	0E9049B	1	ASSY PCB G-PANEL RELAY 12VDC
E	055911	1	BLOCK TERM 20A 12 X 6 X 1100V

ITEM	PART #	QTY	DESCRIPTION
COMPONENTS NOT INCLUDED IN 0G4140E OR WIRE HARNESS			
50	056739	1	RELAY CONTACTOR 12VDC
51	022287	2	SCREW HHC 1/4-20 X 3/4 G5
52	022473	4	WASHER FLAT M6 - 1/4
53	022097	2	WASHER LOCK M6 - 1/4
54	022127	2	NUT HEX 1/4-20 STEEL
55	-	REF.	DPE BREAKER SEE DRAWING 0F9280
56	-	REF.	BOOST RESISTOR SEE DRAWING 0F9280
57	043182	4	WASHER LOCK M3
58	051714	4	NUT HEX M3-0.5 G8 YEL CHR
59	052777	4	WASHER FLAT M3
60	0C2323	2	SCREW PHTT #6-32 X 5/8 ZYC
61	0C2699	2	SCREW PHTT #6-32 X 3/8 ZYC
62	0E7403B	1	FUSE ATO TYPE 10 AMP (RED)
63	0E7403C	1	FUSE ATO TYPE 15 AMP (BLUE)
64	0J7646	1	DECAL CONTROL BOX FUSES
65	0F5461	1	DECAL CPL 5.4/6.8L TB3
66	0F5752A	1	RES WW 10R 5% 15W QK CONN
67	0F6145	A/R	SEAL WEATHER .45" DIA
68	0F7473	1	DECAL H-100 RELAY BD 12V RB1

**GROUP H**

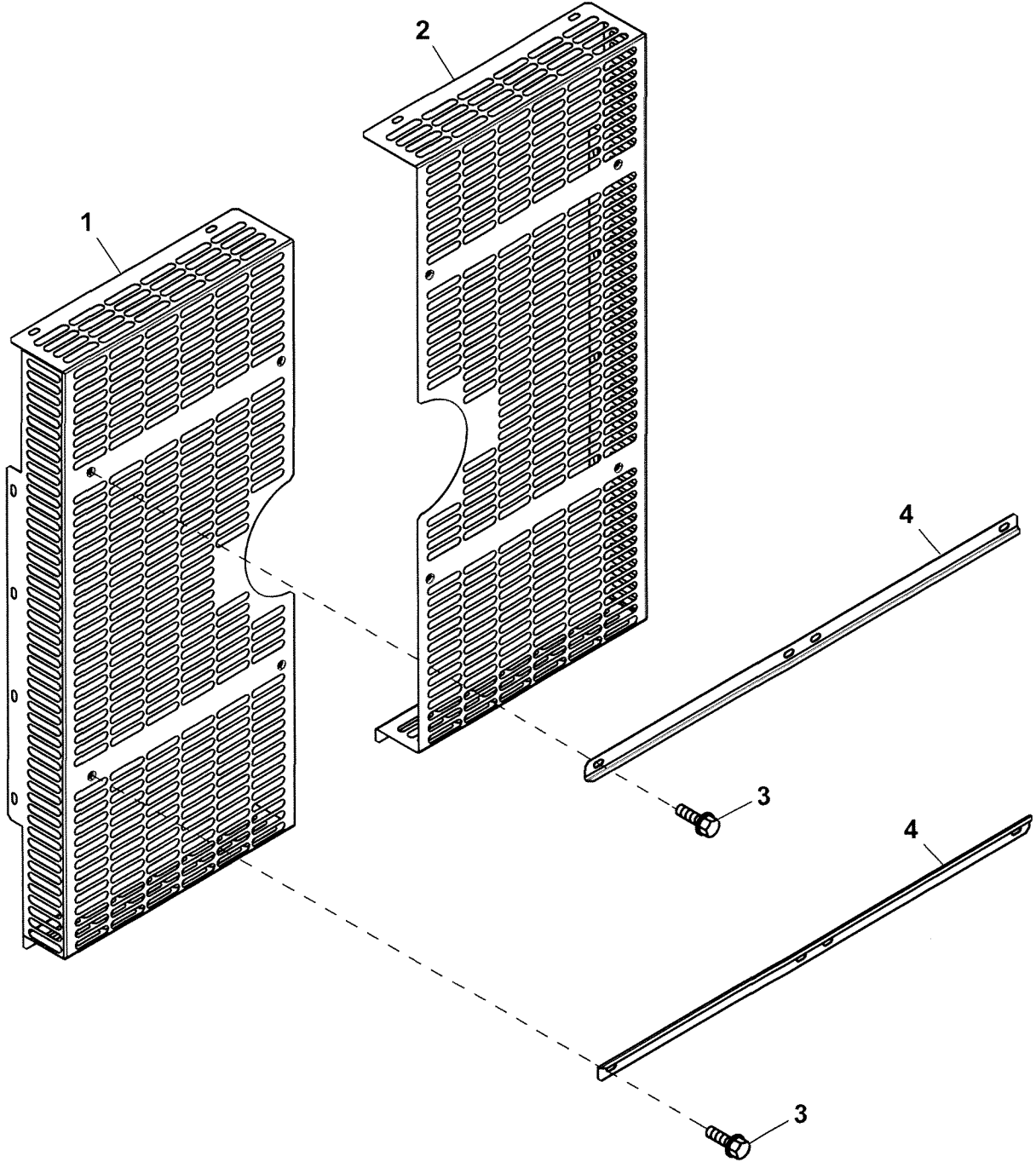

**EXPLODED VIEW: KIT FAN GUARD 4.5L G4**

**DRAWING #: 0G4310**

**GROUP H**

**APPLICABLE TO:**

ITEM	PART#	QTY.	DESCRIPTION
1	0G29160ST03	1	FAN GUARD R/H SIDE
2	0G29170ST03	1	FAN GUARD L/H SIDE
3	090388	24	SCREW HHTT M6-1.0 X 12 ZINC
4	0G24170ST03	2	SUPPORT BRACKET, FAN GUARD

**GROUP C**

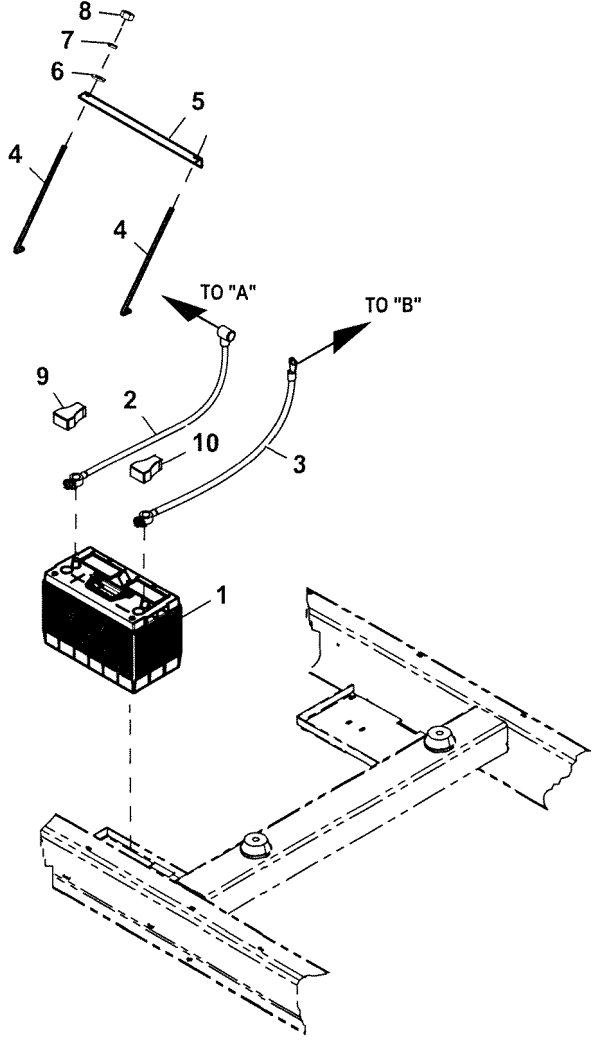

**12V. SINGLE BATTERY**

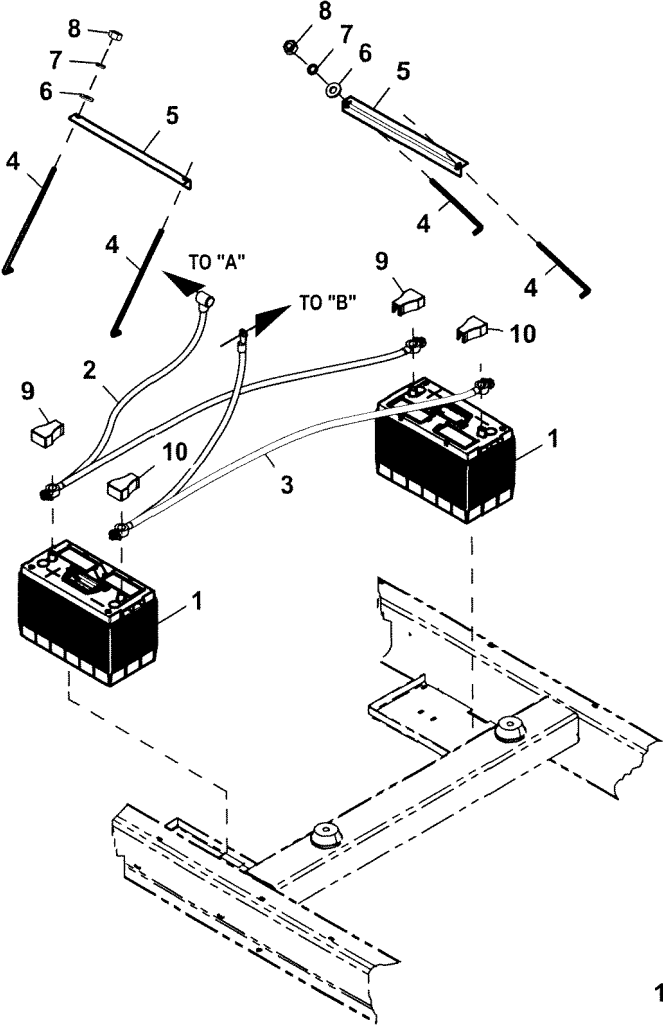

**12V. DUAL BATTERY**

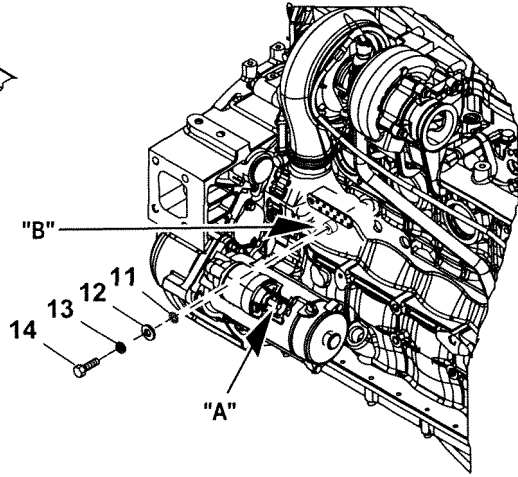

**EXPLODED VIEW: BATT HOLD DWN 31 12V G17****DRAWING #: 0H5386****GROUP C****APPLICABLE TO:**

ITEM	PART#	QTY.	DESCRIPTION
<b>GROUP 31 SINGLE BATTERY KIT 12V. P/N 0H5473</b>			
1	061119	1 (REF)	BATTERY BCI GRP 31 925 CCA
	061119A	1 (REF)	31E BATTERY SERVICE DRY 925CCA
2	0H4637	1	BATTERY CABLE SET 6.7L G17
3	0H4637	1	BATTERY CABLE SET 6.7L G17
4	099049	2	J BOLT,BATTERY TRAY
5	059568H	1	BATT HOLD-DOWN BAR 390 MM
6	058653	2	WASHER FLAT M8
7	022129	2	WASHER LOCK M8-5/16
8	045771	2	NUT HEX M8-1.25 G8 CLEAR ZINC
9	0H4637	1	BATTERY CABLE SET 6.7L G17
10	0H4637	1	BATTERY CABLE SET 6.7L G17
11	0A4456	1	WASHER LOCK SPECIAL 3/8
12	022131	1	WASHER FLAT 3/8-M10 ZINC
13	046526	1	WASHER LOCK M10
14	049814	1	SCREW HHC M10-1.5 X 25 C8.8
<b>GROUP 31 DUAL BATTERY KIT 12V. P/N 0H5474</b>			
1	061119	2 (REF)	BATTERY BCI GRP 31
	061119A	2 (REF)	31E BATTERY SERVICE DRY
2	0H5206	1	DUAL BATT CABLE SET D6.7L G17
3	0H5206	1	DUAL BATT CABLE SET D6.7L G17
4	099049	4	J BOLT,BATTERY TRAY
5	059568H	2	BATT HOLD DOWN BAR 390MM
6	058653	4	WASHER FLAT M8
7	022129	4	WASHER LOCK M8-5/16
8	045771	4	NUT HEX M8-1.25 G8 CLEAR ZINC
9	0H5206	1	DUAL BATT CABLE SET D6.7L G17
10	0H5206	1	DUAL BATT CABLE SET D6.7L G17
11	0A4456	1	WASHER LOCK SPECIAL 3/8
12	022131	1	WASHER FLAT 3/8-M10 ZINC
13	046526	1	WASHER LOCK M10
14	049814	1	SCREW HHC M10-1.5 X 25 C8.8



# GROUP C

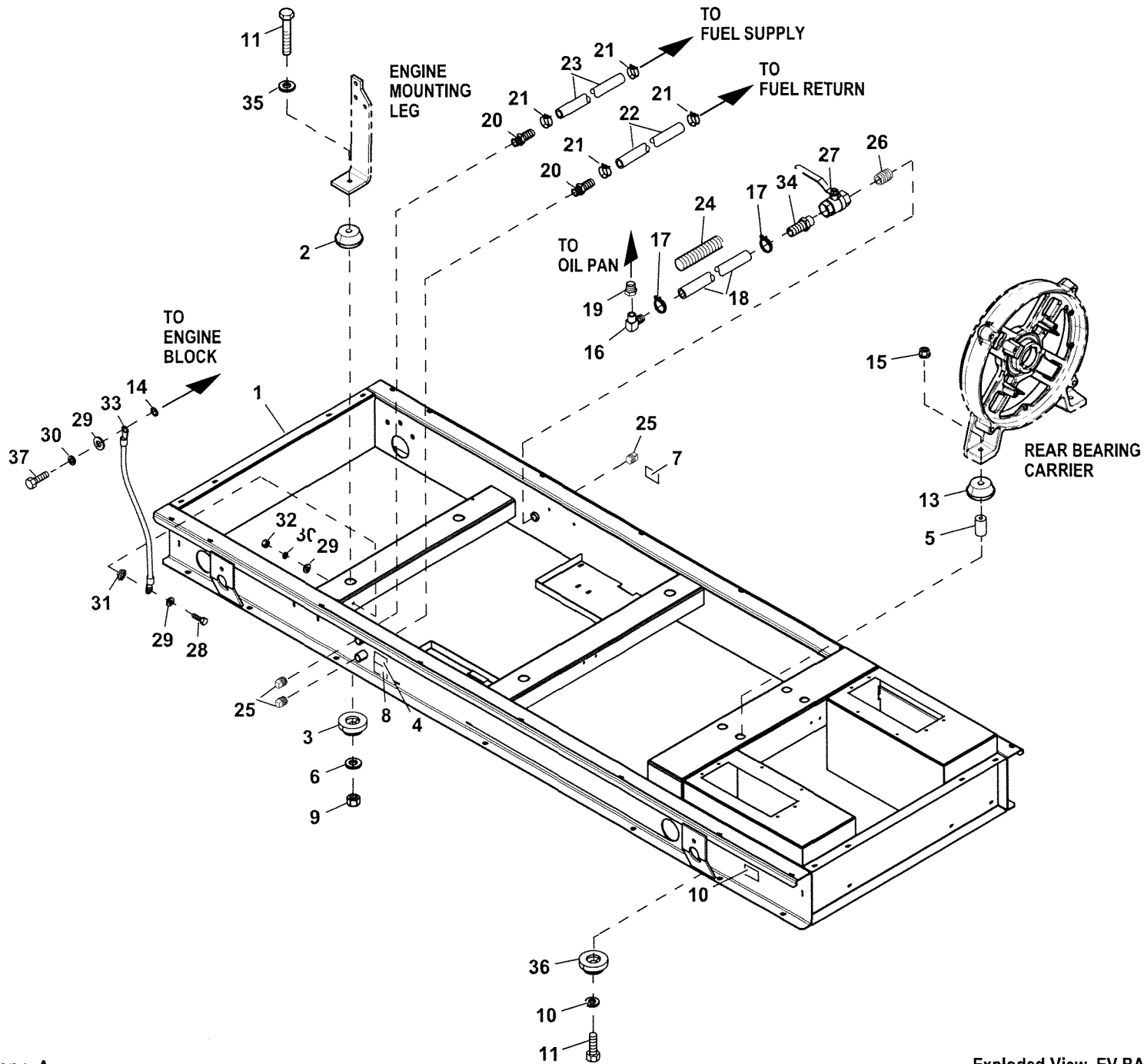

Revision : -A-  
Date : 3/17/11

**EXPLODED VIEW: EV BASEFRAME 6.7L G17 390ALT**

**DRAWING #: 0H9939**

**GROUP C**

**APPLICABLE TO:**

ITEM	PART#	QTY.	DESCRIPTION
(1)1	0H99410ST0R	1	MTG BASE 6.7L G17 C-GRP 390ALT
2	059675	4	MOUNT UPPER VIBRATION
3	059676	4	MOUNT LOWER VIBRATION
4	056727	1	DECAL-FUEL INLET DES
5	052257	2	SPACER .49X.62X1.87 PWDR/ZINC
6	049869	4	WASHER FLAT M16
7	050277	1	DECAL OIL DRAIN
8	056726	1	DECAL-FUEL RETURN
9	060079	4	NUT HEX LOCK M14-2.0 NY INS
10	052259	2	WASHER FLAT M12
11	059983	4	SCREW HHC M14-2.0 X 110 C8.8
12	055597	2	SCREW HHC M12-1.75 X 85 C8.8
13	052251A	2	DAMPENER VIB 50 WHITE
14	027482	1	WASHER SHAKEPROOF EXT 5/16 STL
15	052860	2	NUT TOP LOCK FL M12-1.75
16	056460	1	BARBED EL 90 1/2 NPT X 5/8
17	0G0015	2	CLAMP HOSE 7/8" OD DOUBLE WIRE
18	065386	1	HOSE COOL 5/8 ID 100R6 (12.5"LG)
19	0A4707H	1	ADAPTER 1/2NPT X M22-1.5
20	0D7020	2	BARBED STR 1/2NPT X 3/8"
21	0C7649	4	CLAMP HOSE .38-.87
22	0D7532	1	HOSE DIESEL 3/8" FC598-06 (66"LG)
23	0D7532	1	HOSE DIESEL 3/8" FC598-06 (66"LG)
24	077043E	1	CONDUIT FLEX 1.0"ID (17"LG)
25	024310	3	PLUG STD PIPE 1/2 STEEL SQ HD
26	039413	1	NIPPLE PIPE 1/2 NPT X 2
27	078944	1	VALVE BALL
28	0A8258	1	SCREW HHC M8-1.25 X 25 C10.9
29	022145	3	WASHER FLAT 5/16-M8 ZINC
30	022129	2	WASHER LOCK M8-5/16
31	0C3168	1	WASHER LOCK SPECIAL 5/16
32	045771	1	NUT HEX M8-1.25 G8 CLEAR ZINC
33	0536210292	1	ASSY WIRE #1 18.00"
34	044118	1	BARBED STR 1/2NPT X 5/8
35	022132	4	WASHER FLAT 9/16 ZINC
36	052252	2	DAMPER VIBRATION
37	039253	1	SCREW HHC M8-1.25 X 20 C8.8

(1) SHEET METAL PARTS LISTED IN THE BOM TABLE ARE REPRESENTING GENERIC PARTS (NO COLOR).

- **MANUFACTURING:** FOR CORRECT MATERIAL AND COLOR REFER TO AS400 BOM.
- **CUSTOMER:** FOR CORRECT MATERIAL AND COLOR OF REPLACEMENT PARTS REFER TO "REPLACEMENT SHEET METAL PARTS ORDERING GUIDE-0H7169" INCLUDED IN THE MANUAL OR AVAILABLE ON THE GENERAC WEBSITE.

# GROUP C

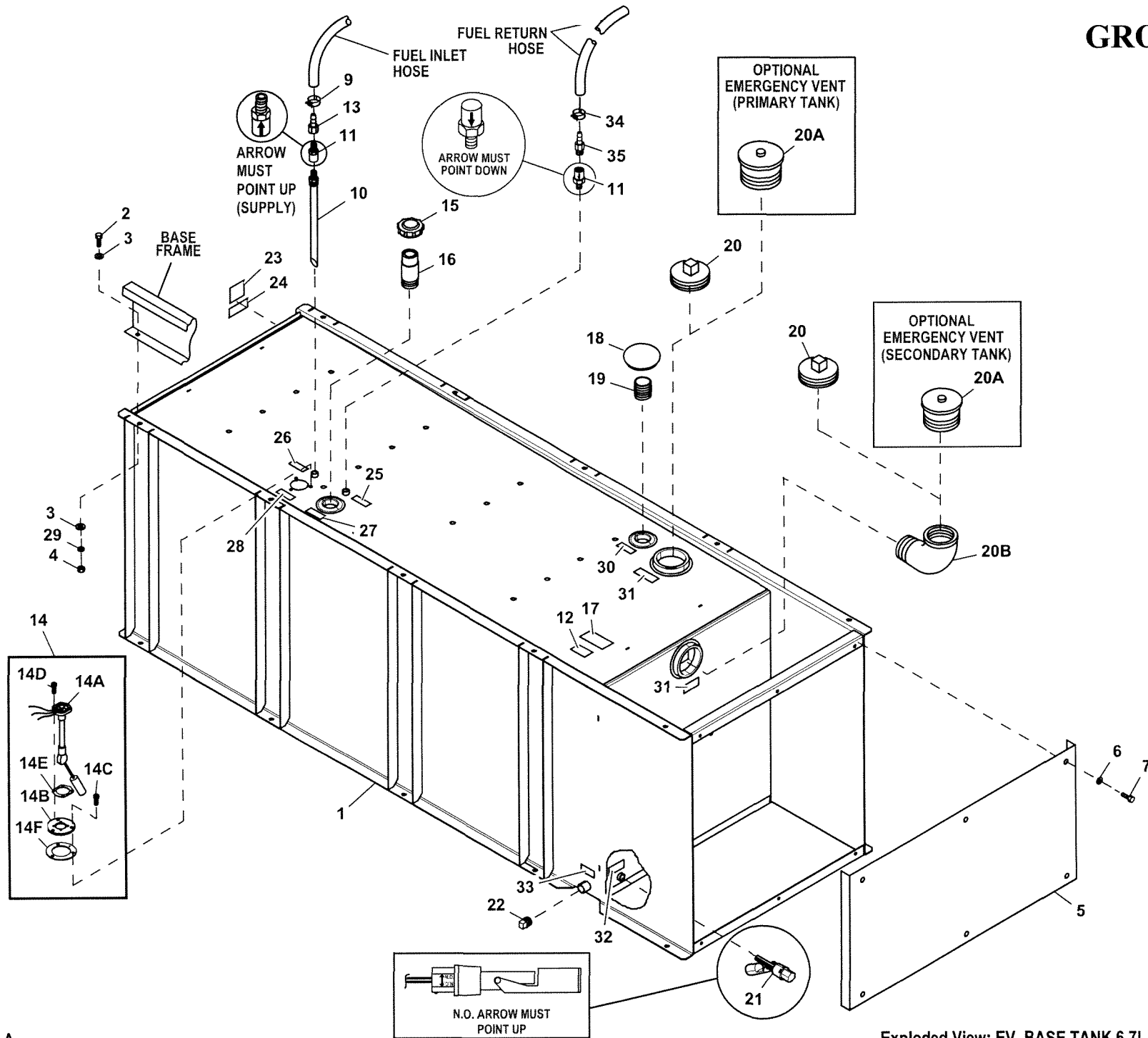

**EXPLODED VIEW: EV, BASE TANK 6.7L C-GRP 1-3FT**

**DRAWING #: 0J1126**

**GROUP C**

**APPLICABLE TO:**

ITEM	PART#	QTY.	DESCRIPTION
(4)1	0J18460ST0R	1	BASETANK CD0095U1N TYPE 1
	0J18480ST0R	1	BASETANK CD0225U2N TYPE 1
	0J18500ST0R	1	BASETANK CD0355U3N TYPE 1
2	0C6789	10	SCREW HHC M12-1.75 X 30 SS FT
3	087171	20	WASHER FLAT 1/2 SS
4	051548	10	NUT HEX M12-1.75 G8 SS
5	0D3747	1	COVER, STUB-UP (1FT)
	0D3747A	1	COVER, STUB-UP (2FT)
	0D3747B	1	COVER, STUB-UP (3FT)
6	050190	6	WASHER FLAT .344 ID X 1.0 OD
7	051754	6	SCREW HHC M8-1.25 X 12 G8.8
9	48031E	1	CLAMP HOSE BAND .66
10	021623	1	FUEL DIP PIPE 233MM
	021623B	1	FUEL DIP PIPE 538MM
	021623D	1	FUEL DIP PIPE 843MM
11	070327	2	VALVE CHECK 3/8 NPT
(3)12	021825	1	DECAL RELIEF VENTING
13	0D3038A	1	BARBED STR FE 3/8 NPT X 3/8
14	0H5761	1	FUEL LEVEL GAUGE KIT-1 FT ELECTRICAL (TO INCLUDE ITEMS 14A, 14B, 14C, 14D, 14E & 14F)
14A	0G8010A	1	ELEC FUEL GAUGE 1FT DW
14B	0D2668	1	PLATE ADAPTOR
14C	052829	3	SCREW SHC M8-1.25 X 14 G12.9
14D	097962	4	SCREW SHC M6-1.0 X 25 G12.9
14E	0E4351	1	GASKET, ROCHESTER FUEL LEVGAUGE
14F	0E4352	1	GASKET, ADAPTER PLATE
14	0H5761A	1	FUEL LEVEL GAUGE KIT-2 FT ELECTRICAL (TO INCLUDE ITEMS 14A, 14B, 14C, 14D, 14E & 14F)
14A	0G8010B	1	FUEL LEVEL GAUGE
14B	0D2668	1	PLATE ADAPTER
14C	052829	3	SCREW SHC M8-1.25 X 14 G12.9
14D	097962	4	SCREW SHC M6-1.0 X 25 G12.9
14E	0E4351	1	GASKET, ROCHESTER FUEL LEVGAUGE
14F	0E4352	1	GASKET, ADAPTER PLATE
14	0H5761B	1	FUEL LEVEL GAUGE KIT-3 FT ELECTRICAL (TO INCLUDE ITEMS 14A, 14B, 14C & 14D, 14E & 14F)
14A	0G8010C	1	FUEL LEVEL GAUGE
14B	0D2668	1	PLATE ADAPTOR
14C	052829	3	SCREW SHC M8-1.25 X 14 C12.9
14D	097962	4	SCREW SHC M6-1.0 X 25 C12.9
14E	0E4351	1	GASKET, ROCHESTER FUEL LEVGAUGE
14F	0E4352	1	GASKET, ADAPTER PLATE
15	0A1492	1	CAP FUEL FILL
(1)16	0D2670	1	NECK FUEL FILL (STANDARD-4")
	(2) 0D2737	1	FUEL FILL AND PRIMARY VENT EXT. KIT 8"
	(2) 0D2739	1	FUEL FILL AND PRIMARY VENT EXT. KIT 13"
	(2) 0D2740	1	FUEL FILL AND PRIMARY VENT EXT. KIT 19"
(3)17	021824	1	WARNING LABEL
18	021178	1	VENT OEM 2" NPT
(1)19	0A7238	1	NIPPLE PIPE 2 NPT X 3.5 BL IRON
	(2) 0D2737	1	FUEL FILL AND PRIMARY VENT EXT. KIT 8"
	(2) 0D2739	1	FUEL FILL AND PRIMARY VENT EXT. KIT 13"
	(2) 0D2740	1	FUEL FILL AND PRIMARY VENT EXT. KIT 19"
(1)20	028619B	2	PLUG PIPE 4" SQ. HD.
(2)20	0D2450	1	VENT EMERGENCY KIT 4" NPT (TO INCLUDE ITEM 20A)
20A	0A1380	2	VENT EMERGENCY 4" NPT
20B	028667	1	ELBOW 90D STREET 4
21	096500V	1	ASSY FUEL LEAK DET ALARM W/CON
22	025655	1	PLUG STD PIPE 3/4" STEEL SQ HD
23	021821	1	PLATE GENERAC
24	021823	1	PLATE UL

**EXPLODED VIEW: EV, BASE TANK 6.7L C-GRP 1-3FT**

**DRAWING #: 0J1126**

**GROUP C**

**APPLICABLE TO:**

ITEM	PART#	QTY.	DESCRIPTION
(3)25	0A1478	1	DECAL FUEL RETURN
(3)26	0A1477	1	DECAL FUEL SUPPLY
(3)27	0A1476	1	LABEL FUEL FILL
(3)28	0A1546	1	LABEL FUEL LEVEL
29	083215	10	WASHER LOCK 1/2 SS
(3)30	0A1479	1	LABEL VENT
(3)31	021826	2	DECAL EMERGENCY VENT
(3)32	0A1481	1	LABEL LEAK DETECTOR
(3)33	0A1482	1	LABEL DRAIN
34	048031N	1	CLAMP HOSE BAND .53
35	055596	1	BARBED STR 3/8NPT X 3/8

NOTES (UNLESS OTHERWISE SPECIFIED):

(1) ITEMS ARE STANDARD COMPONENTS

(2) ITEMS ARE OPTIONAL COMPONENTS

(3) UL STICKER KIT P/N 0A1493.

(4) SHEET METAL PARTS LISTED IN THE BOM TABLE ARE REPRESENTING GENERIC PARTS (NO COLOR)

- MANUFACTURING: FOR CORRECT MATERIAL AND COLOR REFER TO AS400 BOM.
- CUSTOMER: WHEN ORDERING REPLACEMENT PARTS ENTER BASE NUMBER (FIRST 6 DIGITS ONLY) IN THE SYSTEM FOR CORRECT MATERIAL AND COLOR (FOR REFERENCE SEE GUIDELINE 0H7169).

**EXPLODED VIEW: EV, BASE TANK 6.7L C-GRP 1-3FT**

**DRAWING #: 0J1126**

**APPLICABLE TO:**

**GROUP C**

**THIS PAGE LEFT INTENTIONALLY BLANK**

# GROUP D

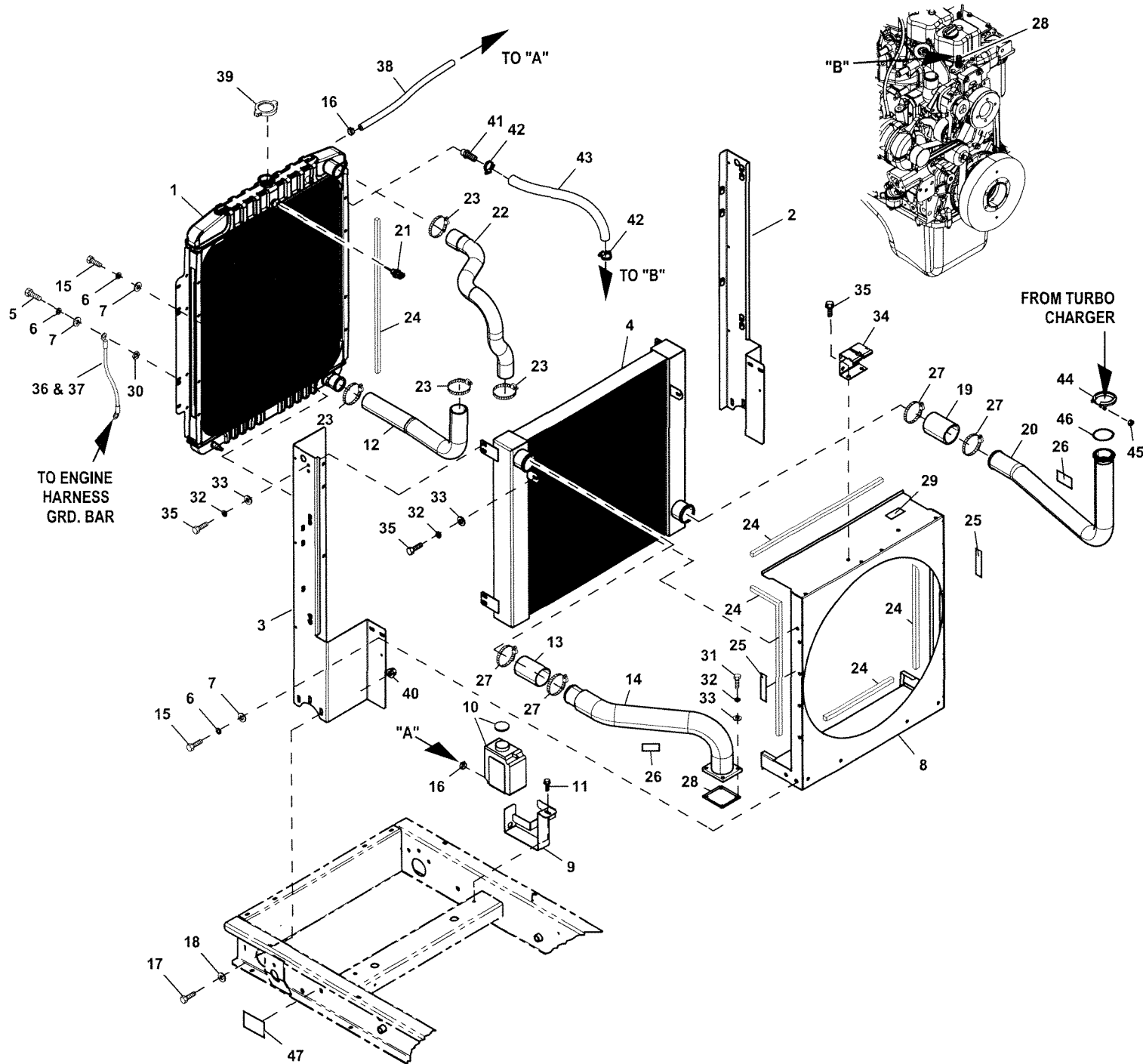

**EXPLODED VIEW: COOLING PACK 6.7L LO G17**

**DRAWING #:0H2157**

**GROUP D**

**APPLICABLE TO:**

ITEM	PART#	QTY.	DESCRIPTION
1	OG1286G	1	RAD RH-IN/OUT DEAERATN BAFFL
2	OG1404AST03	1	SUPPORT, R/H SIDE RADIATOR
3	OG14040ST03	1	SUPPORT, L/H SIDE RADIATOR
4	0H1901	1	ASSY CAC 4.5L (IN=LWR/RT)
5	049814	1	SCREW HHC M10-1.5 X 25 C8.8
6	046526	10	WASHER LOCK M10
7	022131	10	WASHER FLAT 3/8-M10 ZINC
8	OG25960ST03	1	VENTURI, 26"FAN 6.8L C-GRP
9	0D7975	1	WATER BOTTLE BRACKET
10	076749	1	TANK COOLANT RECOVERY
11	0C2454	1	SCREW HWHT M6-1 X 16 N WA Z/JS
12	0H2246	1	HOSE LOWER RAD 6.7L G17 LO
13	084294B	1	HOSE 2.5"ID X 4.0"LG
14	0H2316	1	PIPE, CAC OUT 6.7L LO G17
15	051756	9	SCREW HHC M10-1.5 X 20 C8.8
16	048031C	2	CLAMP HOSE BAND .50
17	051768	6	SCREW HHC M12-1.75 X 25 C8.8
18	049808	6	WASHER FLAT M12
19	0A5398B	1	HOSE 2.5"ID X 4.0"LG
20	0H2321	1	PIPE ASSY, CAC IN 6.7L LO G17
21	0H1827	1	PROBE COOLANT LEVEL 3/8-18NPTF
22	0H1985	1	HOSE UPPER RADIATOR
23	086133C	4	CLAMP HI TORQUE 1.75 - 2.625
24	052250	1	TAPE FOAM 1X1 (184"LG)
25	OG3269	2	DECAL WARNING FAN BI
26	OG3263	2	DECAL WARNING HOT SURFACES BI
27	086133D	4	CLAMP HI TORQUE 2.25 - 3.125
28	0H2288	1	GASKET G17 INTAKE MANIFOLD
29	OG3266	1	DECAL WARNING COOLANT EGLY BI
30	0A4456	1	WASHER LOCK SPECIAL 3/8
31	039287	4	SCREW HHC M8-1.25 X 45 C8.8
32	022129	15	WASHER LOCK M8-5/16
33	022145	15	WASHER FLAT 5/16-M8 ZINC
34	0F2776C	1	BRACKET, SIGNAL COND. 2 PLACE
35	039253	12	SCREW HHC M8-1.25 X 20 C8.8
36	OG7895A	1	HARN RADIATOR GND 80"
37	077043H	1	CONDUIT FLEX .25"ID (80"LG)
38	029032	1	HOSE 9/32 ID (75"LG)
39	0E4162	1	CAP RADIATOR 20 PSI
40	052860	6	NUT TOP LOCK FL M12-1.75
41	035461	1	BARBED STR 1/4NPT X 3/8
42	0C7649	2	CLAMP HOSE .38-.87
43	047290	1	HOSE 3/8 ID SINGLE BRAID (27"LG)
(1)44	0H31940191	REF	CLIP
(1)45	0H31940138	REF	NUT, HEX
(1)46	0H31940137	REF	O-RING
47	050276	1	DECAL RADIATOR DRAIN

(1) SUPPLIED WITH ENGINE



# GROUP D

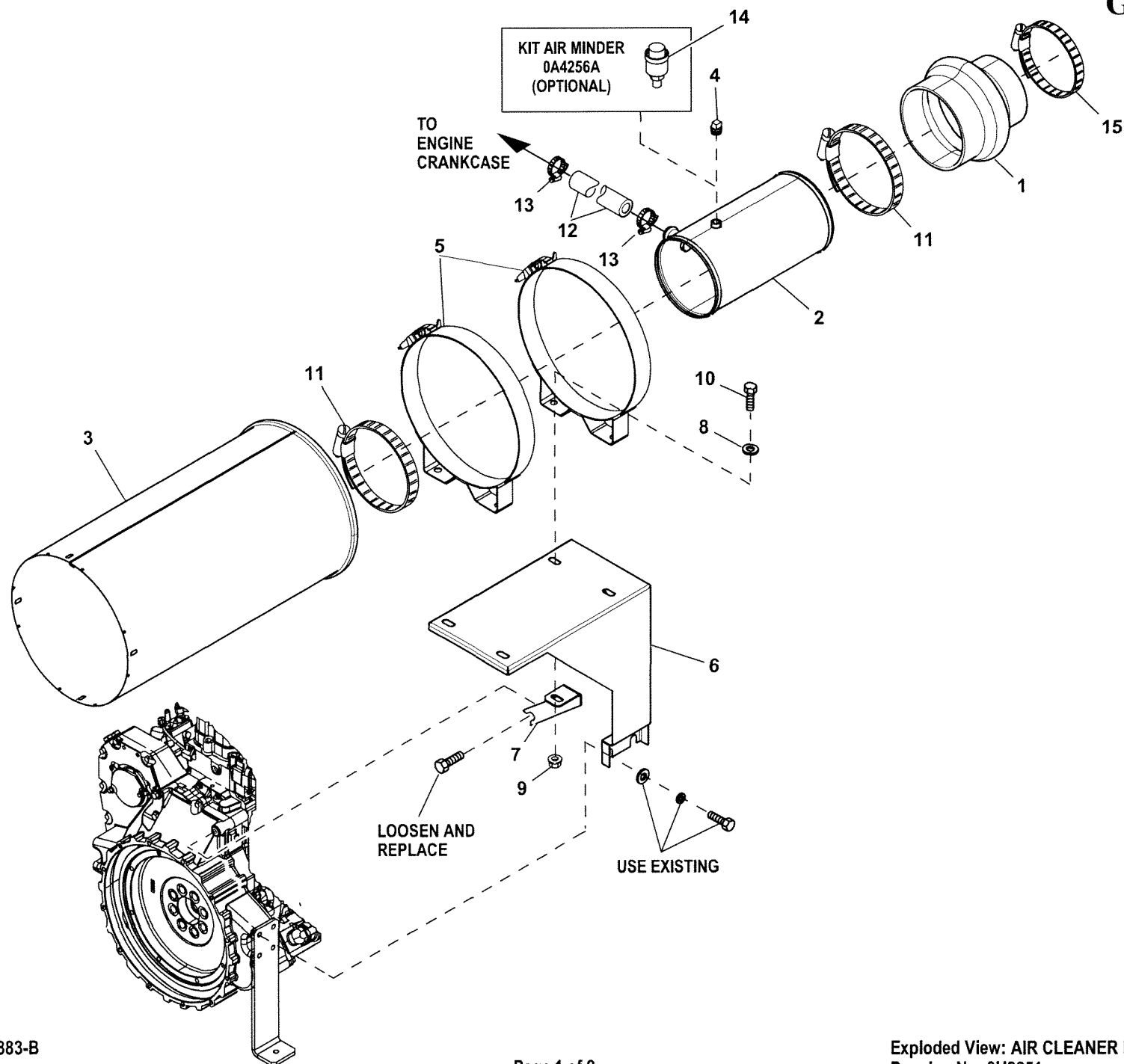

**EXPLODED VIEW: AIR CLEANER D6.7 LO G17****DRAWING #:0H3251****GROUP D****APPLICABLE TO:**

<b>ITEM</b>	<b>PART#</b>	<b>QTY.</b>	<b>DESCRIPTION</b>
1	084725	1	REDUCER HUMP
2	0H2573B	1	WELDMENT, AIR INTAKE TUBE
3	084288	1	AIR CLEANER ECO SE
4	026073	1	PLUG STD PIPE 1/8 STEEL SQ HD
5	084289	2	MOUNTING CLAMP
6	0H32570ST03	1	BRACKET, AIR CLEANER
7	0H32620ST03	1	BRACKET, AIR CLEANER SUPPORT
8	022131	5	WASHER FLAT 3/8-M10 ZINC
9	052859	5	NUT TOP LOCK FL M10-1.50
10	051756	5	SCREW HHC M10-1.5 X 20 C8.8
11	058612	2	CLAMP HOSE #88 5.12-6.00
12	0C5209	1	HOSE 1ID LOW PRES OIL/WATER (9"LG)
13	057824	2	CLAMP HOSE #16 .87-1.50
14	0A4256A	REF	KIT AIR FILTER RESTRICTION IND
15	057648	1	CLAMP HOSE #64 3.56-4.50

# GROUP F

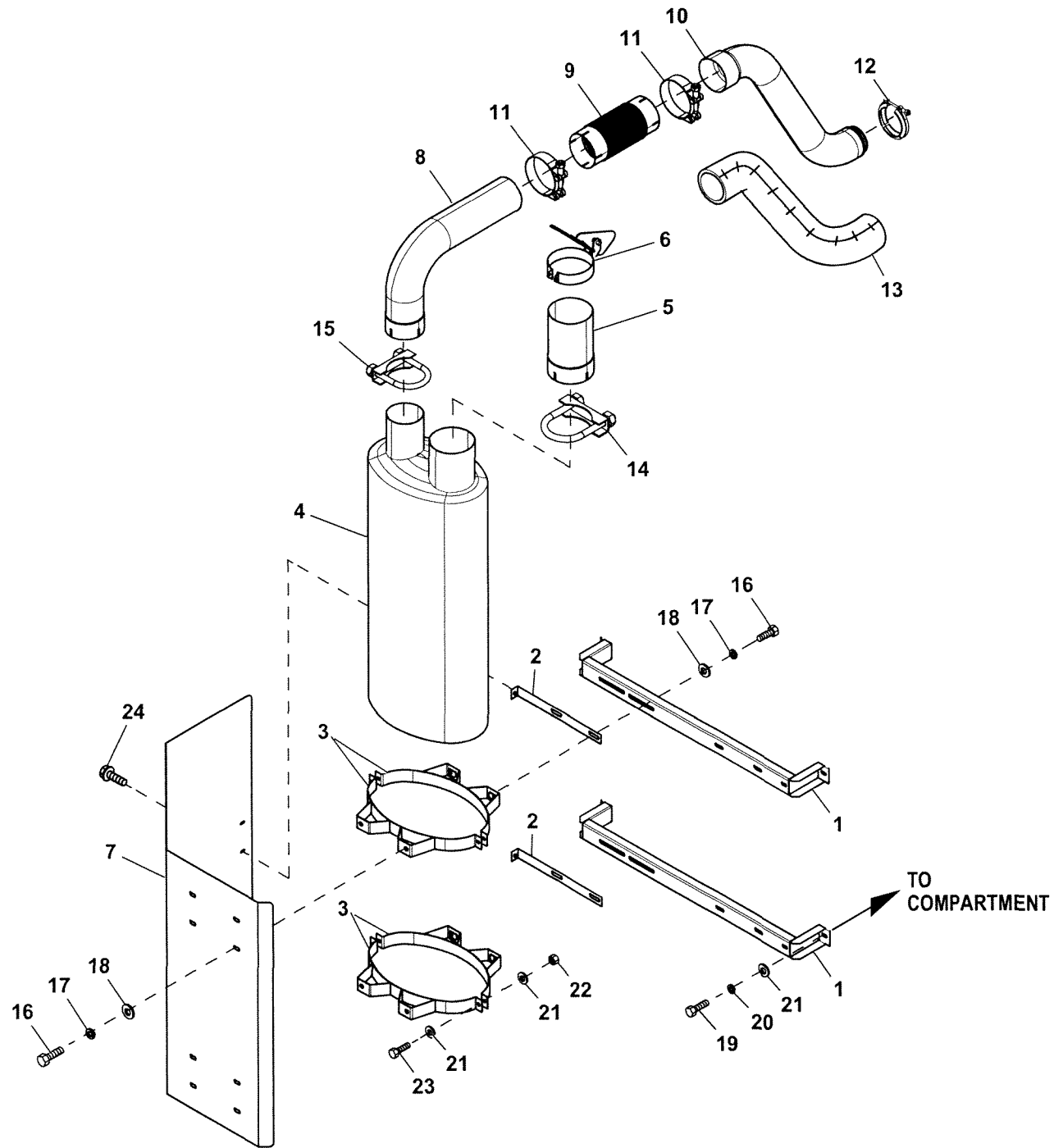

**EXPLODED VIEW: EXHAUST 6.7L G17 100-135KW**

**DRAWING #:0H2765**

**GROUP F**

**APPLICABLE TO:**

ITEM	PART#	QTY.	DESCRIPTION
1	0C2933	2	BRACKET, MUFFLER MOUNTING
(2)2	0C57370ST0R	2	BRACKET, HEAT SHIELD
3	0C5665	4	CLAMP OVAL MUFFLER
4	0C9653	1	MUFFLER 4"INLET/5"OUTLET
5	0C9643	1	TUBE, STRAIGHT
6	065805	1	RAINCAP 5.00 /15.19
(2)7	0C8403AAS0R	1	SHIELD R/H C-GRP MUFFLER HEAT
8	0C9647D	1	TUBE, 90 DEG ELBOW 4" DIA
9	0A5215D	1	FLEX PIPE 4"
10	0H3281	1	TURBO EXHAUST PIPE
11	0C3433C	2	BAND CLAMP 4 DIA
(1)12	0H6348	REF	CLIP 6.7L G17
13	0F9911A	1	BLANKET EXHAUST 1090 LG
14	083468	1	BOLT U 3/8-16 X 4
15	0C5668	1	BOLT U 5/16-18 X 5
16	051756	8	SCREW HHC M10-1.5 X 20 G8.8
17	046526	8	WASHER LOCK M10
18	022131	8	WASHER FLAT M10-3/8 ZINC
19	055173	4	SCREW HHC M8-1.25 X 20 G10.9
20	022129	4	WASHER LOCK M8-5/16
21	022145	12	WASHER FLAT M8-5/16 ZINC
22	049820	4	NUT LOCK HEX M8-1.25 NYL INS
23	039287	4	SCREW HHC M8-1.25 X 45 G8.8 FT
24	0C2454	2	SCREW TH-FRM M6-1 X 16 N WA Z/JS

(1) SUPPLIED WITH ENGINE

(2) SHEET METAL PARTS LISTED IN THE BOM TABLE ARE REPRESENTING GENERIC PARTS (NO COLOR)

- MANUFACTURING: FOR CORRECT MATERIAL AND COLOR REFER TO AS400 BOM.
- CUSTOMER: WHEN ORDERING REPLACEMENT PARTS ENTER BASE NUMBER (FIRST 6 DIGITS ONLY) IN THE SYSTEM FOR CORRECT MATERIAL AND COLOR (FOR REFERENCE SEE GUIDELINE 0H7169).

# GROUP F

○ STATES FOAM IS ON NEAR SIDE  
○ STATES FOAM IS ON FAR SIDE

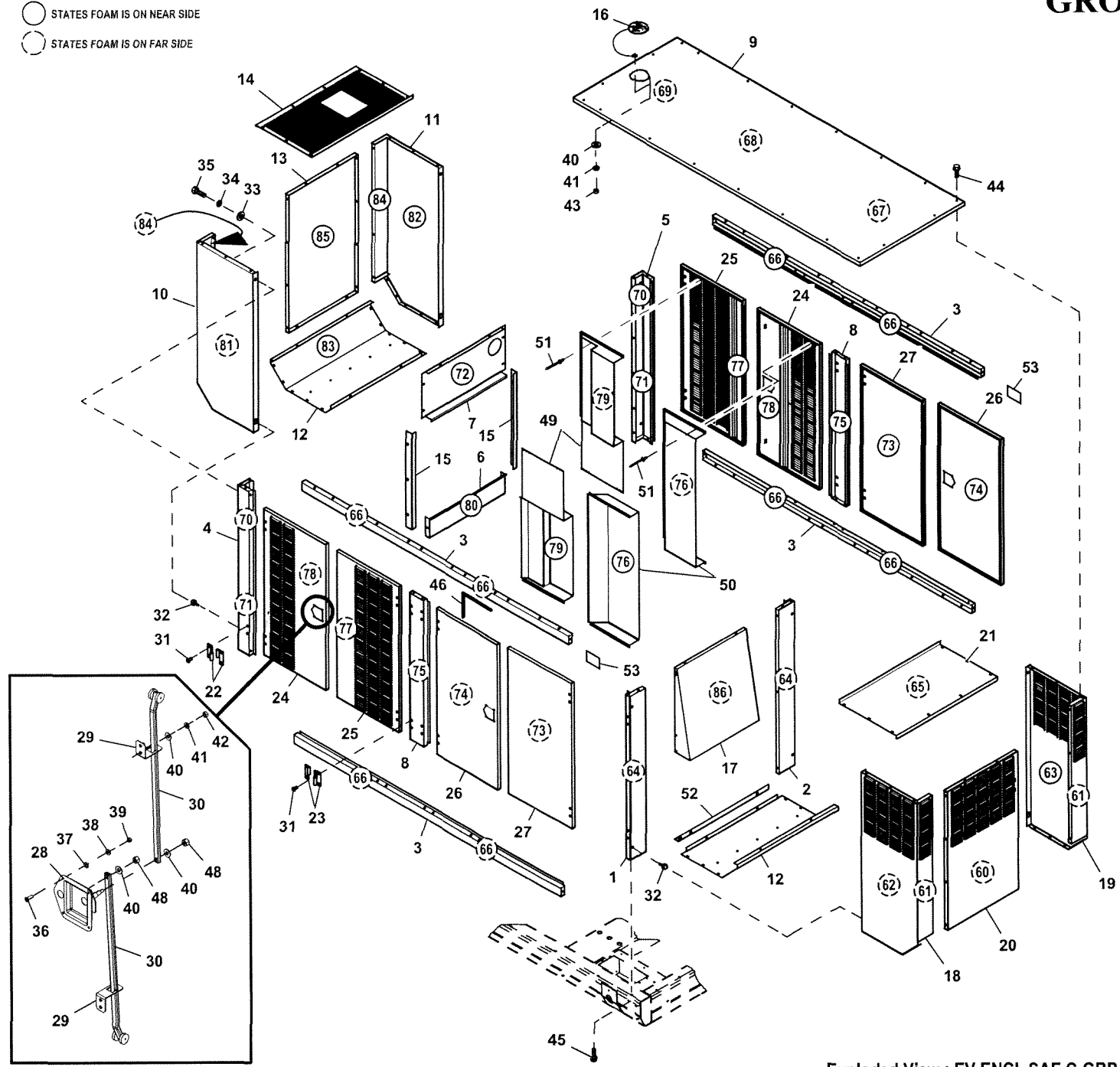

**EXPLODED VIEW: EV ENCL SAE C-GRP**

**DRAWING #:0J0433**

**GROUP F**

**APPLICABLE TO:**

ITEM	PART#	QTY.	DESCRIPTION
(1)1	0H98290ST0R	1	CORNER POST LH REAR
(1)2	0H98300ST0R	1	CORNER POST RH REAR
(1)3	0H98340ST0R	4	SIDE BRACE TOP&BTM C-GRP
(1)4	0H98310ST0R	1	CORNER POST LH FRONT C-GRP
(1)5	0H98320ST0R	1	CORNER POST RH FRONT C-GRP
(1)6	0G63850ST0R	1	LOWER RADIATOR BLOCK OFF
(1)7	0H27690ST0R	1	FRONT BRACE TOP 6.7L G17
(1)8	0H97910ST0R	2	CENTER DOOR SUPPORT
(1)9	0J19690AL0R	1	ASSY, ROOF C-GRP
10	0C7990	1	DUCT, FRONT LH
11	0C7989	1	DUCT, FRONT RH
12	0C8391	2	DUCT, BOTTOM
13	0C7987	1	DUCT, FRONT PANEL
(1)14	0H28160AL0R	1	DUCT FRONT TOP R/H ALUM
(1)15	0G14150ST0R	2	RADIATOR BLOCK OFF 6.8L 135KW
16	0C2634A	1	ASSY ACCESS COVER
(1)17	0H98350ST0R	1	REAR SOUND BAFFLE, C-GRP
18	0C7984	1	DUCT, REAR LH
19	0C7983	1	DUCT, REAR RH
20	0C7985	1	DUCT, REAR PANEL
21	0C8392	1	DUCT,REAR TOP
22	0C3595	8	ASSY M8 HINGE
23	0C3595A	8	ASSY M8 HINGE LH
(1)24	0J00780ST0R	2	DOOR LH LOUVERED
(1)25	0J00790ST0R	2	DOOR RH LOUVERED
(1)26	0J00800ST0R	2	DOOR LH SOLID
(1)27	0J00810ST0R	2	DOOR RH SOLID
28	0J0992	4	T-HANDLE, 2-POINT DBL DOOR
(1)29	0J16010ST0R	8	BRACKET, ROD GUIDE
30	0J0993	8	ROLLER ROD, T-HANDLE
31	0A5991	64	SCREW BHSC M8-1.25 X 16 SS
32	0C3393	4	SCREW SHOULDER M8-1.25 X 20
33	022145	4	WASHER FLAT 5/16-M8 ZINC
34	022129	4	WASHER LOCK M8-5/16
35	042907	4	SCREW HHC M8-1.25 X 16 C8.8
36	0C6749	16	SCREW PPHM M4-0.7 X 12 SS
37	022769	4	WASHER LOCK INT #10
38	080490	16	WASHER FLAT #8 SS
39	0C6748	16	NUT HEX LOCK M4-0.7 SS NYL INS
40	022473	17(REF)	WASHER FLAT 1/4-M6 ZINC
41	022097	17	WASHER LOCK M6-1/4
42	049813	16	NUT HEX M6-1.0 G8 CLEAR ZINC
43	026311	1	NUT LOCK HEX JAM 1/4-20 NYL IN
44	0C2454	112	SCREW HWHT M6-1 X 16 N WA Z/JS
45	0E3257	14	SCREW HWHTF M6-1.0 X 16
46	0A9881	1	TRIM VINYL SEAL
47	066760	1	STRIP SEALANT 1/8 X 1 (NOT SHOWN)
48	027529	8(REF)	NUT HEX LOCK 1/4-20 NY INS
(1)49	0J29770ST0R	2	DOOR BAFFLE
(1)50	0J02700ST0R	2	DOOR BAFFLE
51	087233	16	RIVET POP .1875 X .450 SS
(1)52	0C53560ST0R	1	PLATE VARMINIT BLOCKOFF
53	0E7222	2	RAIN SHIELD,DOOR JAMB
54	0C3948	8	SPACER DOOR (NOT SHOWN)
60	0J0553EG	1	INSUL REAR DUCT SIDE
61	0J0553EF	2	INSUL REAR DUCT SIDE
62	0J0553EE	1	INSUL REAR DUCT LH SIDE
63	0J0553ED	1	INSUL REAR DUCT RH SIDE
64	0J0553BJ	2	INSUL REAR CORNER POST
65	0J0553EH	1	INSUL REAR DUCT TOP
66	0J0553BI	8	INSUL SIDE SUPPORT RAIL
67	0J0553BL	1	INSUL ROOF REAR
68	0J0553BM	1	INSUL ROOF MID
69	0J0621N	1	INSUL HIGH HEAT FRONT ROOF

EXPLODED VIEW: EV ENCL SAE C-GRP

DRAWING #:0J0433

GROUP F

APPLICABLE TO:

ITEM	PART#	QTY.	DESCRIPTION
70	0J0621G	2	INSUL HIGH HEAT FRNT CNR POST
71	0J0553BG	2	INSUL FRONT CORNER POST
72	0J0621H	1	INSUL HIGH HEAT FRNT CTR SPT
73	0J0553K	2	INSUL RH SOLID DOOR
74	0J0553L	2	INSUL LH SOLID DOOR
75	0J0553E	2	INSUL CTR DOOR SUPPORT
76	0J0553Y	2	INSUL DOOR BAFFLE
77	0J0553M	2	INSUL RH LOUVERED DOOR
78	0J0553N	2	INSUL LH LOUVERED DOOR
79	0J0553EJ	2	INSUL DOOR BAFFLE
80	0J0553BH	1	INSUL BOTTOM FRONT SUPPORT
81	0J0553EA	1	INSUL FRONT DUCT LH SIDE
82	0J0553DZ	1	INSUL FRONT DUCT RH SIDE
83	0J0553CD	1	INSUL FRONT DUCT BTM
84	0J0553EB	2	INSUL FRONT DUCT SIDE
85	0J0553EC	1	INSUL FRONT DUCT SIDE
86	0J0553EI	1	INSUL REAR DUCT BAFFLE

(1) SHEET METAL PARTS LISTED IN THE BOM TABLE ARE REPRESENTING GENERIC PARTS (NO COLOR).

- **MANUFACTURING:** FOR CORRECT MATERIAL AND COLOR REFER TO AS400 BOM.
- **CUSTOMER:** FOR CORRECT MATERIAL AND COLOR OF REPLACEMENT PARTS REFER TO "REPLACEMENT SHEET METAL PARTS ORDERING GUIDE-0H7169" INCLUDED IN THE MANUAL OR AVAILABLE ON THE GENERAC WEBSITE.

**EXPLODED VIEW: EV ENCL SAE C-GRP**

**DRAWING #:0J0433**

**APPLICABLE TO:**

**GROUP F**

This page left blank intentionally



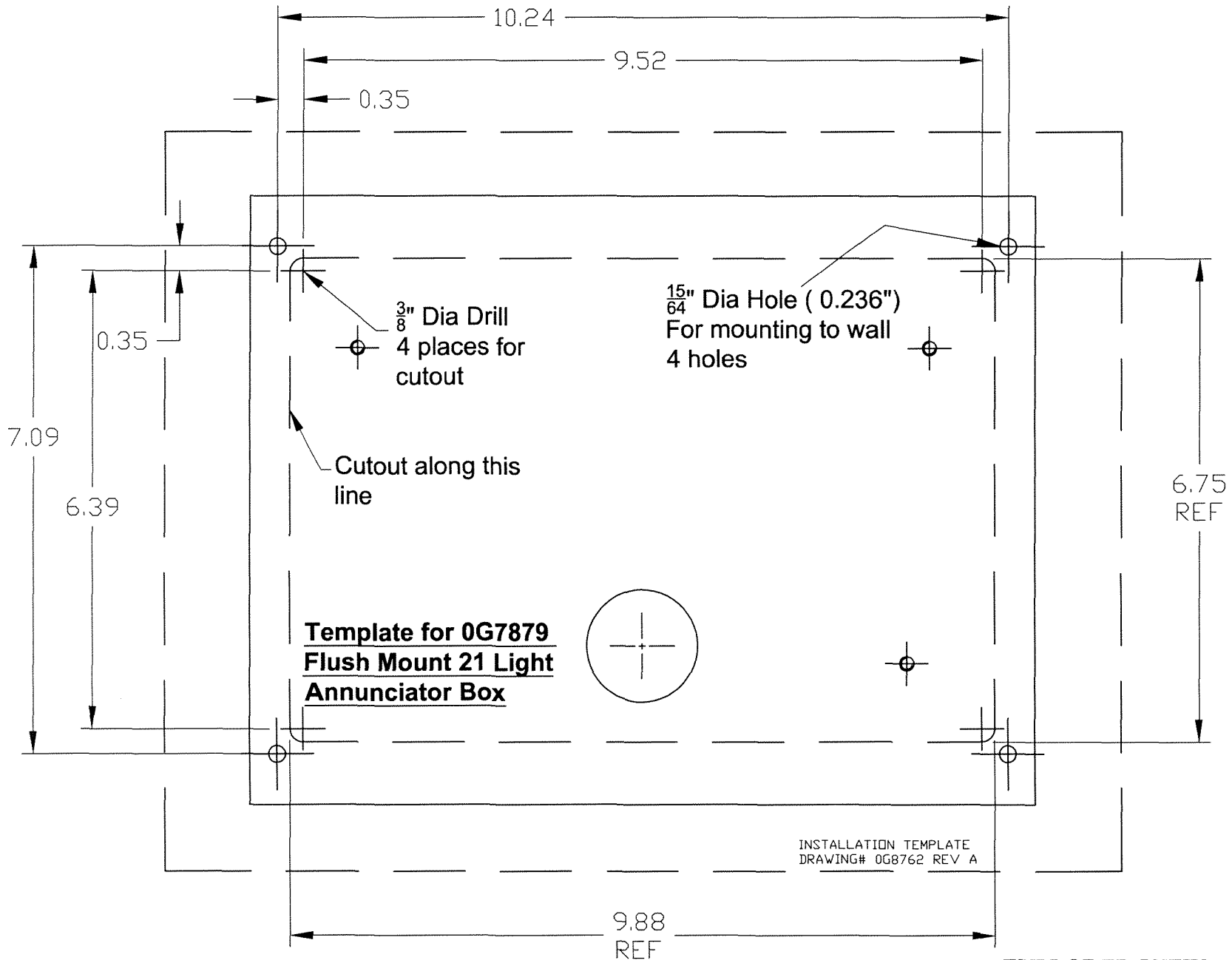

EXPLODED VIEW: INSTALLATION TEMPLATE

DRAWING #: 0G8762

APPLICABLE TO:

GROUP G

**THIS PAGE IS LEFT INTENTIONALLY BLANK**

OPTION 1 - SINGLE PHASE, H-PANEL OR G-PANEL CONTROL PANEL

LEGEND	
AR	- ALTERNATOR ROTOR
AS	- ALTERNATOR STATOR
AVR	- AUTOMATIC VOLTAGE REGULATOR
CT	- CURRENT TRANSFORMER
EF	- EXCITER FIELD
MLCB	- MAIN CIRCUIT BREAKER
NB	- NEUTRAL BLOCK
PME	- PERMANENT MAGNET EXCITER

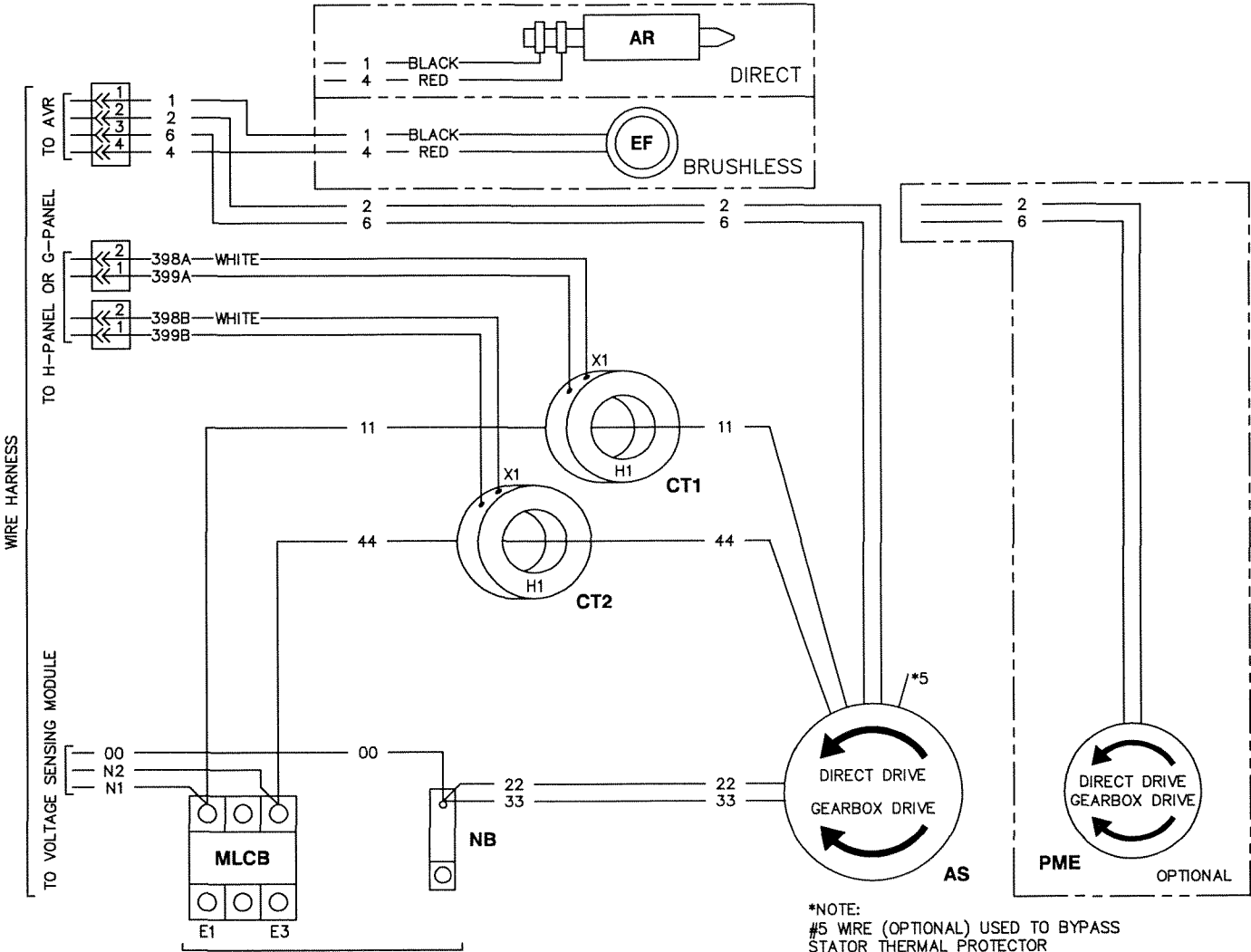

GENERATOR OUTPUT  
CUSTOMER CONNECTION  
E1-E3 \*240VAC

E1-N OR E3-N \*120VAC

\*NOTE: THE 8TH DIGIT OF THE MODEL NUMBER SPECIFIES OUTPUT VOLTAGE ON UNITS BEFORE 2010

THE 7TH DIGIT OF THE MODEL NUMBER SPECIFIES OUTPUT VOLTAGE ON UNITS 2010 TO PRESENT

"A" = 120/240VAC 60HZ

"M" = 110/220VAC 50HZ

\*NOTE:  
#5 WIRE (OPTIONAL) USED TO BYPASS  
STATOR THERMAL PROTECTOR

## OPTION 2 - THREE PHASE, H-PANEL OR G-PANEL CONTROL PANEL, DIRECT DRIVE, 6 LEAD

LEGEND	
AR	- ALTERNATOR ROTOR
AS	- ALTERNATOR STATOR
AVR	- AUTOMATIC VOLTAGE REGULATOR
CT	- CURRENT TRANSFORMER
EF	- EXCITER FIELD
MLCB	- MAIN CIRCUIT BREAKER
NB	- NEUTRAL BLOCK
PME	- PERMANENT MAGNET EXCITER

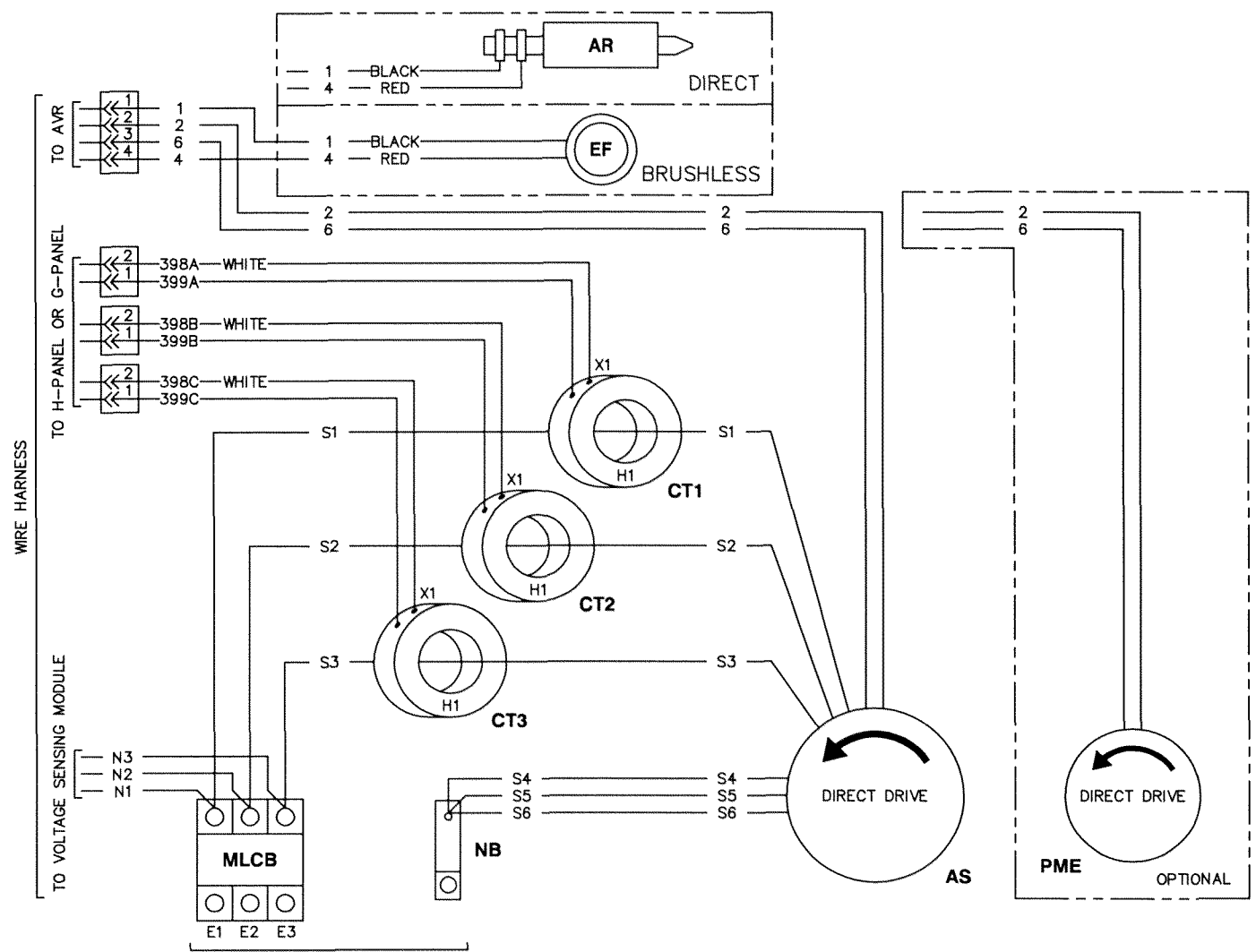

GENERATOR OUTPUT  
CUSTOMER CONNECTION

E1 TO E2  
E2 TO E3 } \*208VAC OR \*480VAC  
E1 TO E3 }

E1, E2 OR E3 TO NB = \*120VAC OR \*277VAC  
\*NOTE: THE 8TH DIGIT OF THE MODEL NUMBER SPECIFIES OUTPUT VOLTAGE ON UNITS BEFORE 2010  
THE 7TH DIGIT OF THE MODEL NUMBER SPECIFIES OUTPUT VOLTAGE ON UNITS 2010 TO PRESENT  
"G" = 120/208VAC 60HZ  
"K" = 277/480VAC 60HZ

OPTION 3 - THREE PHASE, H-PANEL OR G-PANEL CONTROL PANEL, GEARBOX (REVERSE ROTATION)

LEGEND	
AR	- ALTERNATOR ROTOR
AS	- ALTERNATOR STATOR
AVR	- AUTOMATIC VOLTAGE REGULATOR
CT	- CURRENT TRANSFORMER
EF	- EXCITER FIELD
MLCB	- MAIN CIRCUIT BREAKER
NB	- NEUTRAL BLOCK
PME	- PERMANENT MAGNET EXCITER

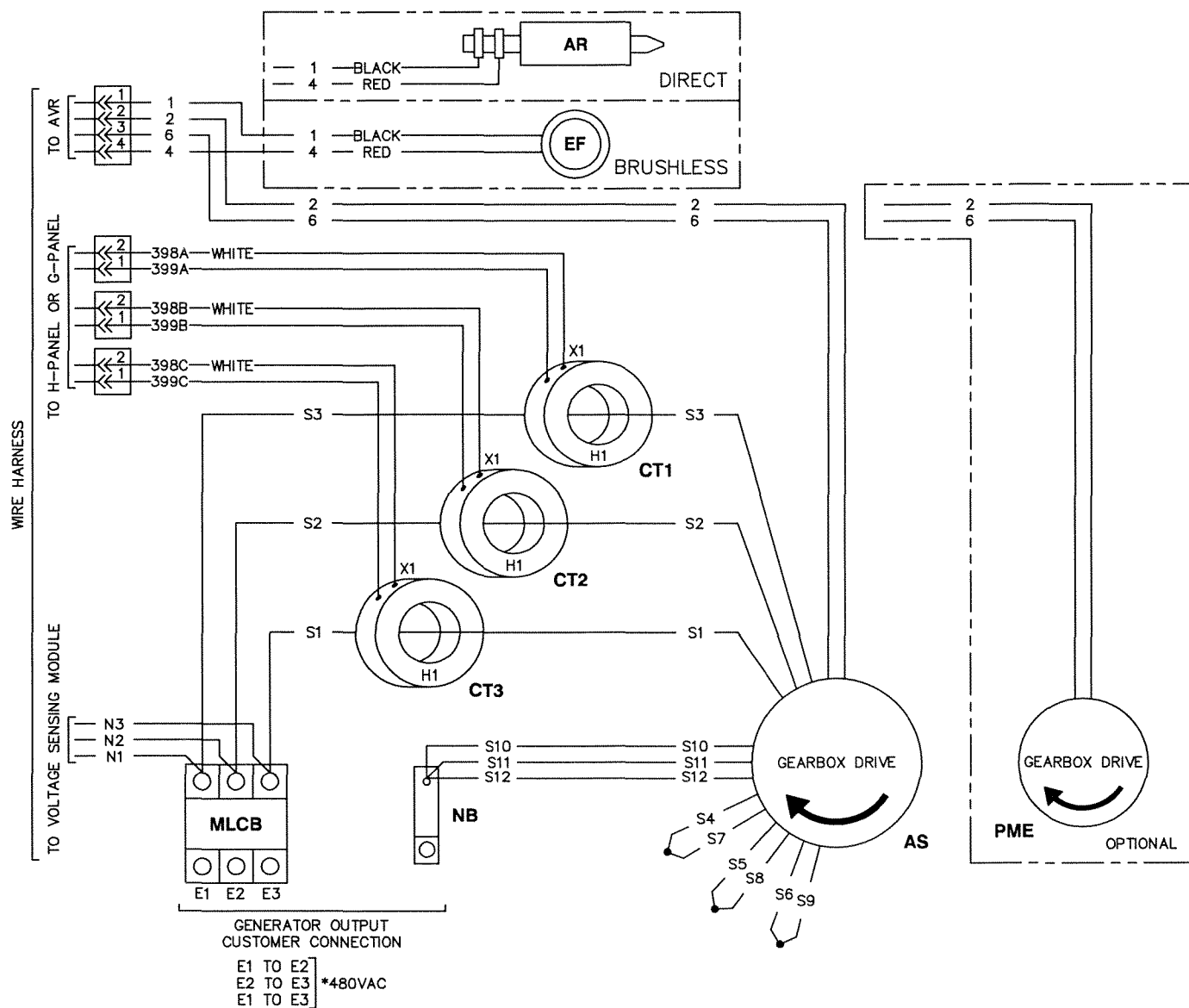

GENERATOR OUTPUT  
CUSTOMER CONNECTION  
E1 TO E2  
E2 TO E3 \*480VAC  
E1 TO E3

E1, E2 OR E3 TO NB = \*277VAC  
\*NOTE: THE 8TH DIGIT OF THE MODEL NUMBER SPECIFIES OUTPUT VOLTAGE ON UNITS BEFORE 2010  
THE 7TH DIGIT OF THE MODEL NUMBER SPECIFIES OUTPUT VOLTAGE ON UNITS 2010 TO PRESENT  
"K" = 277/480VAC 60HZ

OPTION 4 - THREE PHASE DELTA, H-PANEL OR G-PANEL CONTROL PANEL, DIRECT DRIVE, 7 LEAD

LEGEND	
AR	- ALTERNATOR ROTOR
AS	- ALTERNATOR STATOR
AVR	- AUTOMATIC VOLTAGE REGULATOR
CT	- CURRENT TRANSFORMER
EF	- EXCITER FIELD
MLCB	- MAIN CIRCUIT BREAKER
NB	- NEUTRAL BLOCK
PME	- PERMANENT MAGNET EXCITER

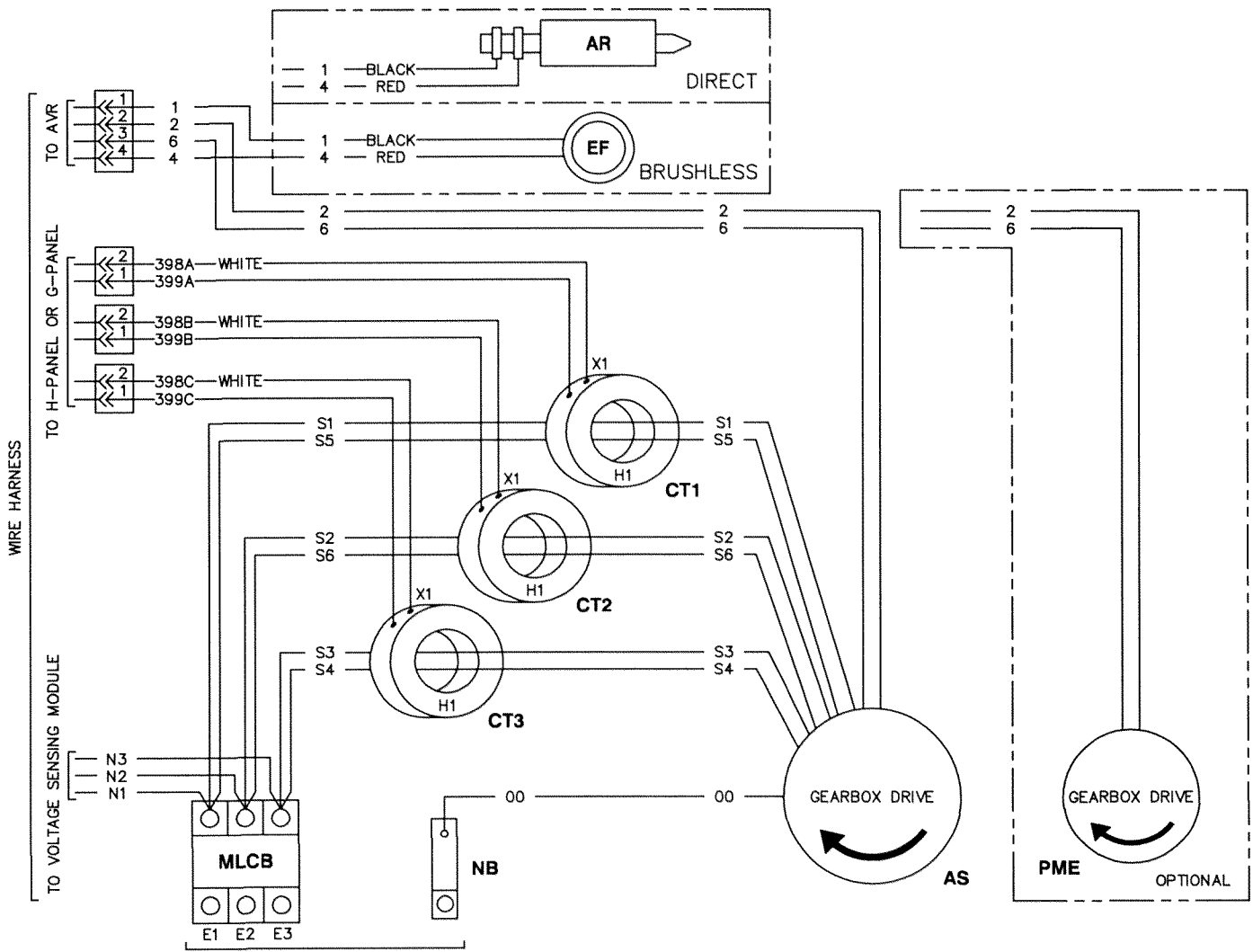

GENERATOR OUTPUT  
CUSTOMER CONNECTION  
E1 TO E2  
E2 TO E3 \*240VAC  
E1 TO E3

E1-N OR E3-N = \*120VAC

\*NOTE: THE 8TH DIGIT OF THE MODEL NUMBER SPECIFIES OUTPUT VOLTAGE ON UNITS BEFORE 2010  
THE 7TH DIGIT OF THE MODEL NUMBER SPECIFIES OUTPUT VOLTAGE ON UNITS 2010 TO PRESENT

\*J = 120/240VAC 60HZ

OPTION 5 - THREE PHASE SERIES WYE, H-PANEL OR G-PANEL CONTROL PANEL, DIRECT DRIVE, 12 LEAD

LEGEND	
AR	- ALTERNATOR ROTOR
AS	- ALTERNATOR STATOR
AVR	- AUTOMATIC VOLTAGE REGULATOR
CT	- CURRENT TRANSFORMER
EF	- EXCITER FIELD
MLCB	- MAIN CIRCUIT BREAKER
NB	- NEUTRAL BLOCK

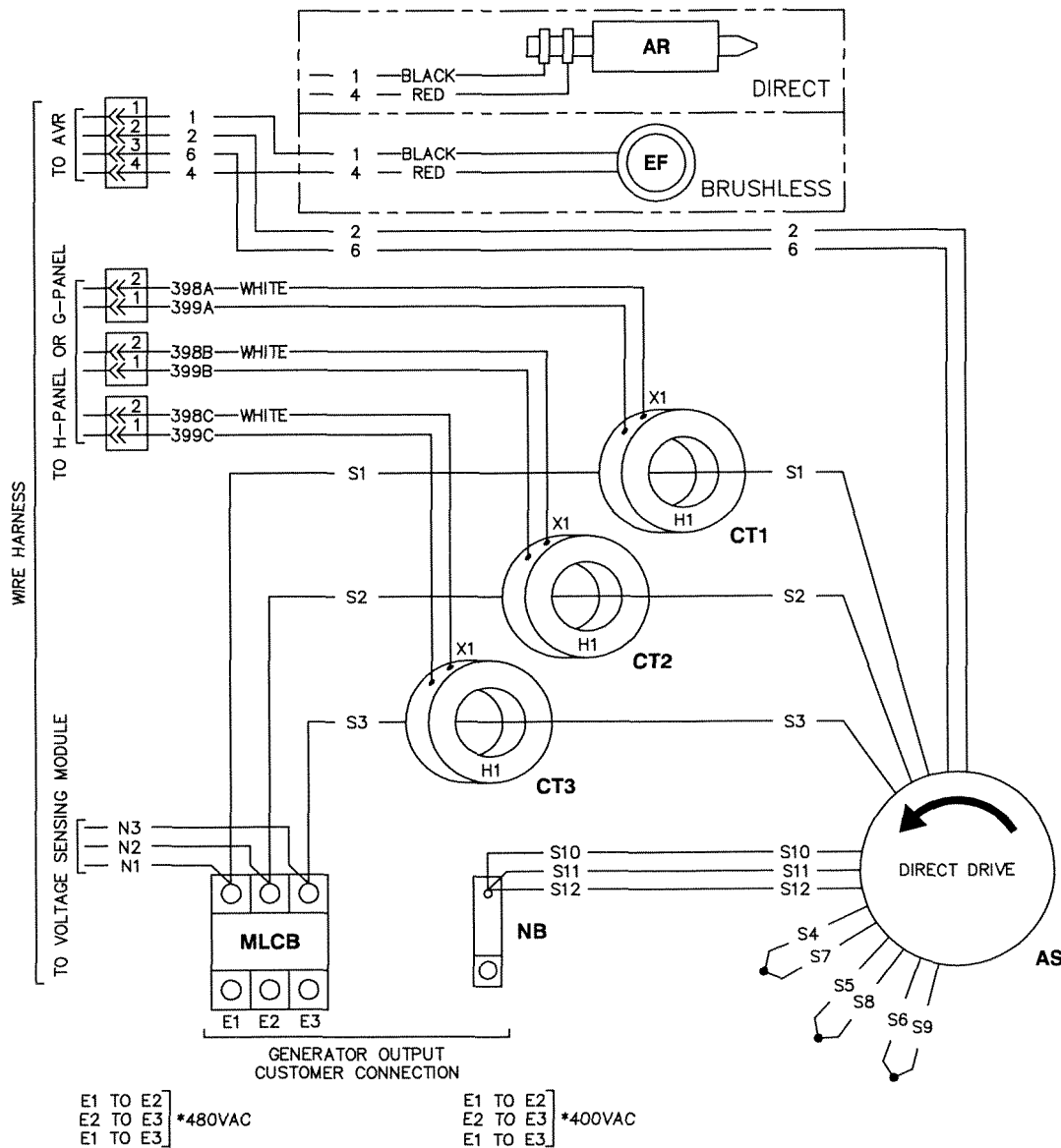

E1-N OR E2-N OR E3-N = \*277VAC      E1-N OR E2-N OR E3-N = \*231VAC  
 \*NOTE: THE 8TH DIGIT OF THE MODEL NUMBER SPECIFIES OUTPUT VOLTAGE ON UNITS BEFORE 2010  
 THE 7TH DIGIT OF THE MODEL NUMBER SPECIFIES OUTPUT VOLTAGE ON UNITS 2010 TO PRESENT  
 "K" = 277/480VAC 60HZ  
 "R" = 231/400VAC 50HZ

OPTION 6 - THREE PARALLEL ZIG ZAG, H-PANEL OR G-PANEL CONTROL PANEL, DIRECT DRIVE, 12 LEAD

LEGEND	
AR	- ALTERNATOR ROTOR
AS	- ALTERNATOR STATOR
AVR	- AUTOMATIC VOLTAGE REGULATOR
CT_	- CURRENT TRANSFORMER
EF	- EXCITER FIELD
MLCB	- MAIN CIRCUIT BREAKER
NB	- NEUTRAL BLOCK

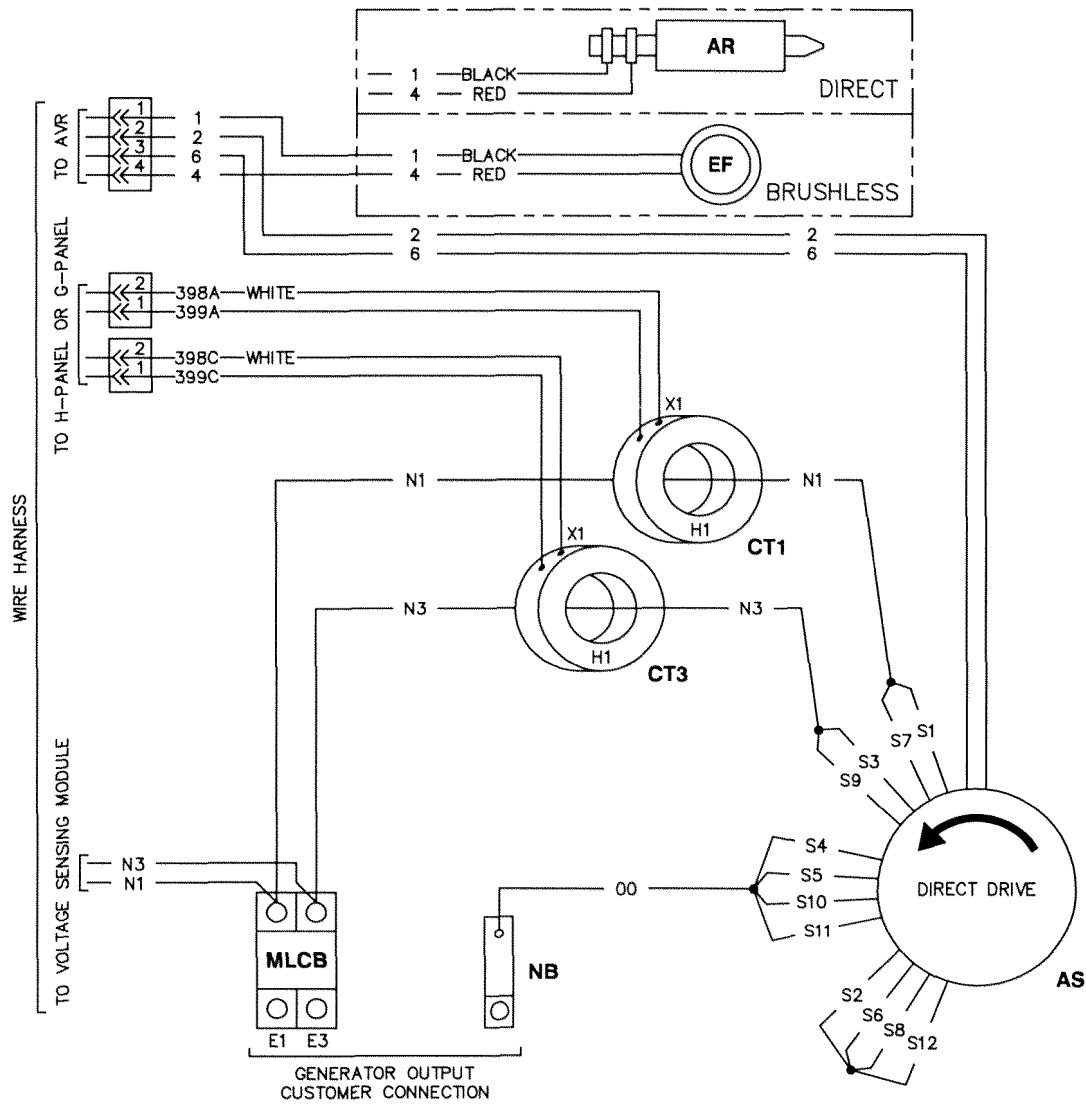

GENERATOR OUTPUT  
CUSTOMER CONNECTION  
E1 TO 00] \*115VAC OR \*120VAC  
E3 TO 00] \*115VAC OR \*120VAC  
E1 TO E3] \*200VAC OR \*240VAC

\*NOTE: THE 8TH DIGIT OF THE MODEL NUMBER SPECIFIES OUTPUT VOLTAGE ON UNITS BEFORE 2010  
THE 7TH DIGIT OF THE MODEL NUMBER SPECIFIES OUTPUT VOLTAGE ON UNITS 2010 TO PRESENT  
"A" = 120/240VAC 60HZ  
"N" = 115/200VAC 50HZ



OPTION 7 - THREE PHASE SERIES DELTA, H-PANEL OR G-PANEL CONTROL PANEL, DIRECT DRIVE, 12 LEAD

LEGEND	
AR	- ALTERNATOR ROTOR
AS	- ALTERNATOR STATOR
AVR	- AUTOMATIC VOLTAGE REGULATOR
CT	- CURRENT TRANSFORMER
EF	- EXCITER FIELD
MLCB	- MAIN CIRCUIT BREAKER
NB	- NEUTRAL BLOCK

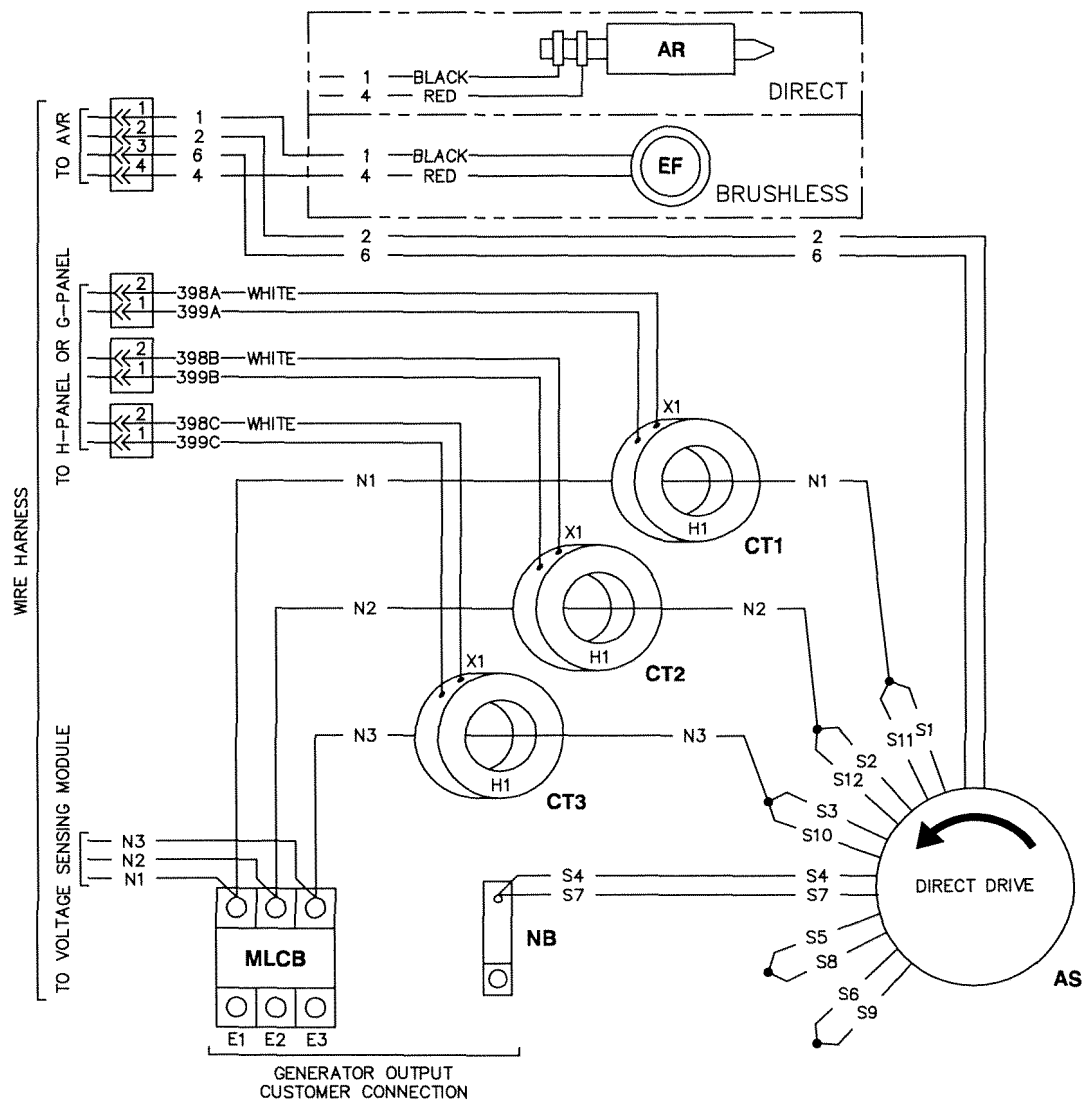

E1 TO E2] E1 TO E2] \*240VAC E1 TO E2] \*200VAC  
 E2 TO E3] E2 TO E3] \*240VAC E2 TO E3] \*200VAC  
 E1 TO E3] E1 TO E3] \*240VAC E1 TO E3] \*200VAC

E1-N OR E2-N OR E3-N = \*120VAC E1-N OR E2-N OR E3-N = \*100VAC  
 \*NOTE: THE 8TH DIGIT OF THE MODEL NUMBER SPECIFIES OUTPUT VOLTAGE ON UNITS BEFORE 2010  
 THE 7TH DIGIT ON THE MODEL NUMBER SPECIFIES OUTPUT VOLTAGE ON UNITS 2010 TO PRESENT  
 "D" = 120/240VAC 1 $\phi$ /3 $\phi$  60HZ  
 "J" = 120/240VAC 60HZ  
 "P" = 100/200VAC 50HZ

OPTION 8 - THREE PHASE PARALLEL WYE, H-PANEL OR G-PANEL CONTROL PANEL, DIRECT DRIVE, 12 LEAD

LEGEND	
AR	- ALTERNATOR ROTOR
AS	- ALTERNATOR STATOR
AVR	- AUTOMATIC VOLTAGE REGULATOR
CT_	- CURRENT TRANSFORMER
EF	- EXCITER FIELD
MLCB	- MAIN CIRCUIT BREAKER
NB	- NEUTRAL BLOCK

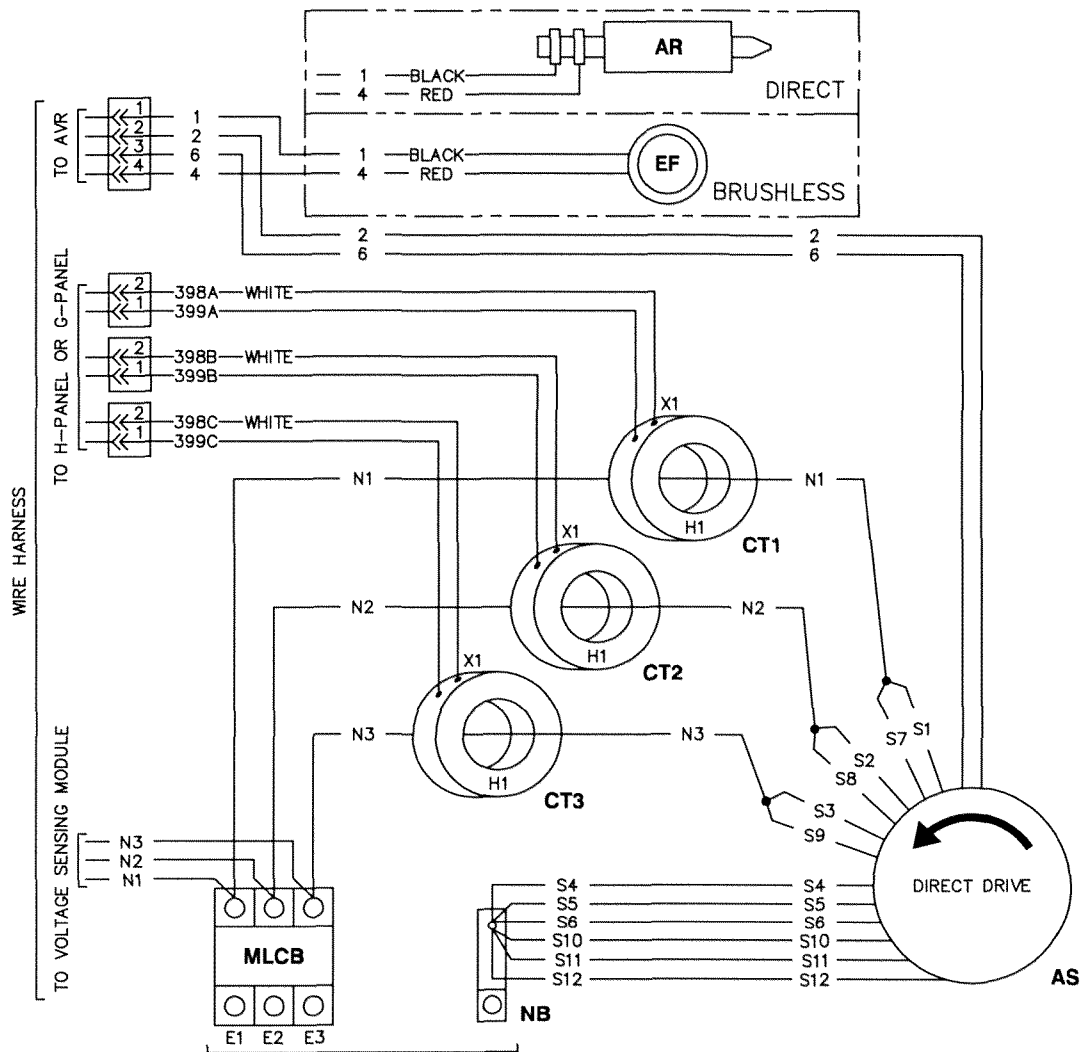

GENERATOR OUTPUT  
CUSTOMER CONNECTION

E1 TO E2  
E2 TO E3 \*208VAC  
E1 TO E3

E1-N OR E2-N OR E3-N = \*120VAC

\*NOTE: THE 8TH DIGIT OF THE MODEL NUMBER SPECIFIES OUTPUT VOLTAGE ON UNITS BEFORE 2010  
THE 7TH DIGIT OF THE MODEL NUMBER SPECIFIES OUTPUT VOLTAGE ON UNITS 2010 TO PRESENT  
\*G\* = 120/208VAC 60HZ

OPTION 9 - THREE PHASE SERIES DELTA, H-PANEL OR G-PANEL CONTROL PANEL, GEARBOX (REVERSE ROTATION), 12 LEAD

LEGEND	
AR	- ALTERNATOR ROTOR
AS	- ALTERNATOR STATOR
AVR	- AUTOMATIC VOLTAGE REGULATOR
CT	- CURRENT TRANSFORMER
EF	- EXCITER FIELD
MLCB	- MAIN CIRCUIT BREAKER
NB	- NEUTRAL BLOCK

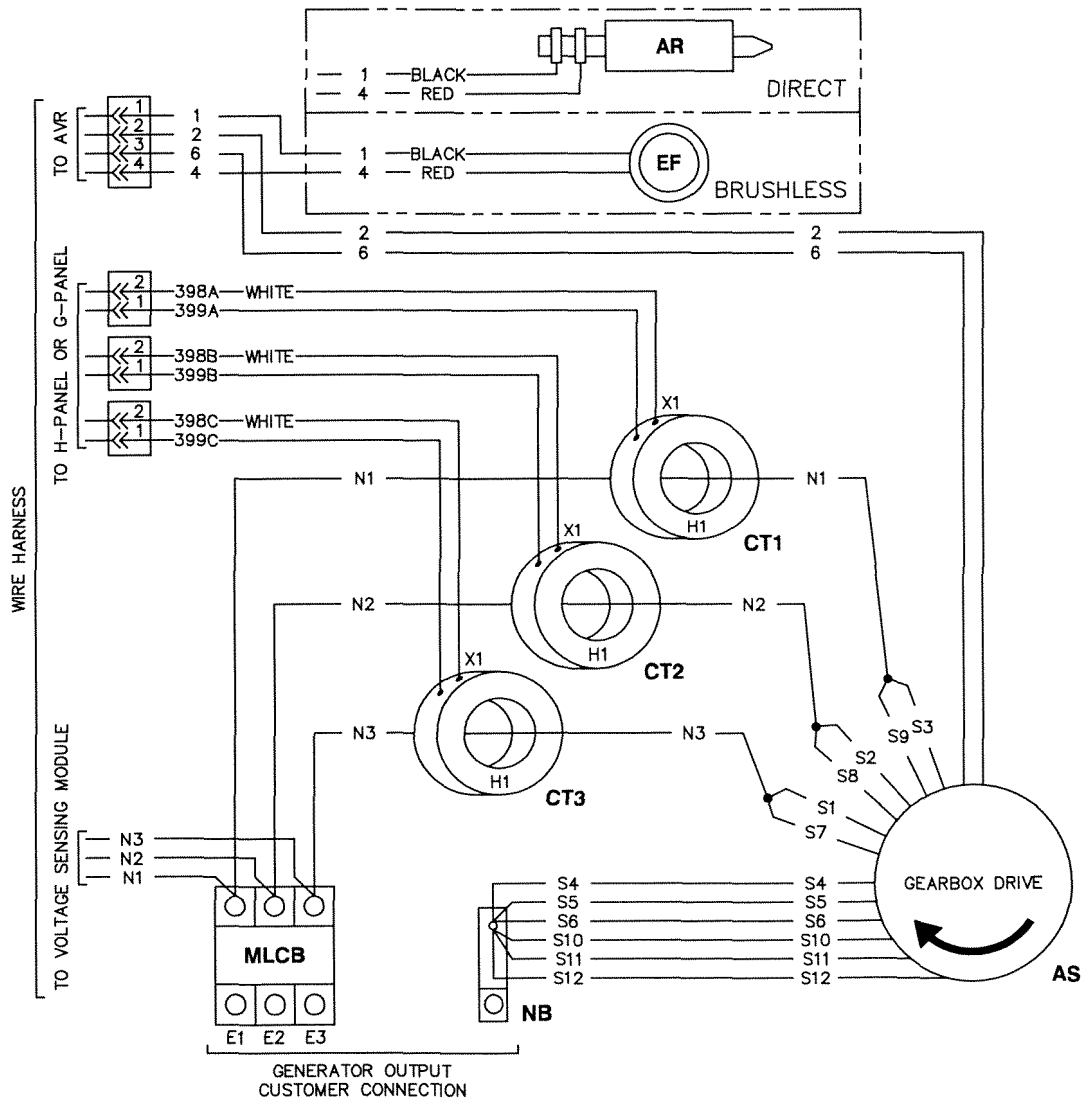

GENERATOR OUTPUT  
CUSTOMER CONNECTION  
E1 TO E2  
E2 TO E3 \*208VAC  
E1 TO E3

E1-N OR E2-N OR E3-N = \*120VAC

\*NOTE: THE 8TH DIGIT OF THE MODEL NUMBER SPECIFIES OUTPUT VOLTAGE ON UNITS BEFORE 2010  
THE 7TH DIGIT OF THE MODEL NUMBER SPECIFIES OUTPUT VOLTAGE ON UNITS 2010 TO PRESENT  
"G" = 120/208VAC 60HZ

**PAGE LEFT BLANK INTENTIONALLY**

## LEGEND

- |                                       |                                   |
|---------------------------------------|-----------------------------------|
| AH1 - ALARM HORN                      | IP - INJECTOR PUMP                |
| ALT - DC CHARGE ALTERNATOR            | J_ - ENGINE CONTROL MODULE CONN.  |
| AVR - AUTO VOLTAGE REGULATOR          | LD - LEAK DETECTOR                |
| BCC - BATTERY CHARGER CONNECTOR       | MLCB - MAIN LINE CIRCUIT BREAKER  |
| BCH - BATTERY CHARGER                 | MOD - MODEM CONNECTOR             |
| CB - CIRCUIT BREAKER DPE              | MPU1 - MAGNETIC PICKUP            |
| CO - CROSSOVER CONNECTOR              | NB - NEUTRAL BLOCK                |
| COM - COMMUNICATION CONNECTOR         | OPS1 - OIL PRESSURE SENDER        |
| CT_ - CURRENT TRANSFORMER             | OTS_ - OIL TEMPERATURE SENDER     |
| DB - DIODE BRIDGE                     | R_ - RESISTOR                     |
| ECM - ELECTRONIC CONTROL MODULE       | RB_ - RELAY BOARD                 |
| ES1 - EMERGENCY STOP SWITCH           | RB_A - RELAY BOARD CONNECTOR      |
| EXC - EXCITER                         | SC - STARTER CONTACTOR            |
| F_ - FUSE                             | SM - STARTER MOTOR                |
| FLS_ - FUEL LEVEL SENDER              | SW1 - OFF/AUTO/MANUAL SWITCH      |
| GA_ - GOVERNOR ACTUATOR               | SWC - SWITCH CONNECTOR            |
| GD - GOVERNOR DRIVER                  | TB_ - TERMINAL BLOCK              |
| GFCI - GROUND FAULT CIRCUIT INTERRUPT | WLS_ - COOLANT LEVEL SENDER       |
| GND - GROUND BAR CONNECTION           | WTS_ - COOLANT TEMPERATURE SENDER |
| IFT - INTERFACE TRANSFORMER           |                                   |

NOTE: ALL WIRES 18 AWG  
300V UL LISTED UNLESS  
SHOWN OTHERWISE

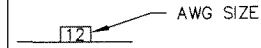

## COMPONENTS LOCATED IN ALTERNATOR CONNECTION BOX

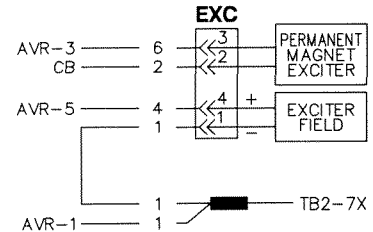
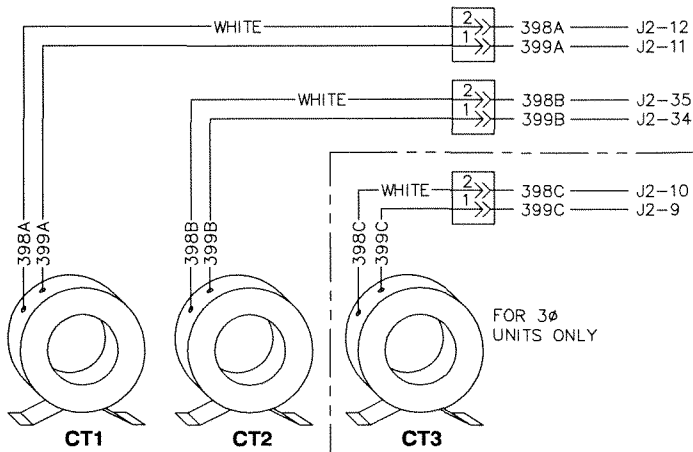

SEE DRAWING OH9846 FOR CT WIRING.

## COMPONENTS LOCATED IN HIGH VOLTAGE CUSTOMER CONNECTION MODULE

### CONNECTIONS FOR 1Ø UNIT

NOTE: ALL WIRES IN THIS SECTION ARE 600V RATED

### CONNECTIONS FOR 3Ø UNIT

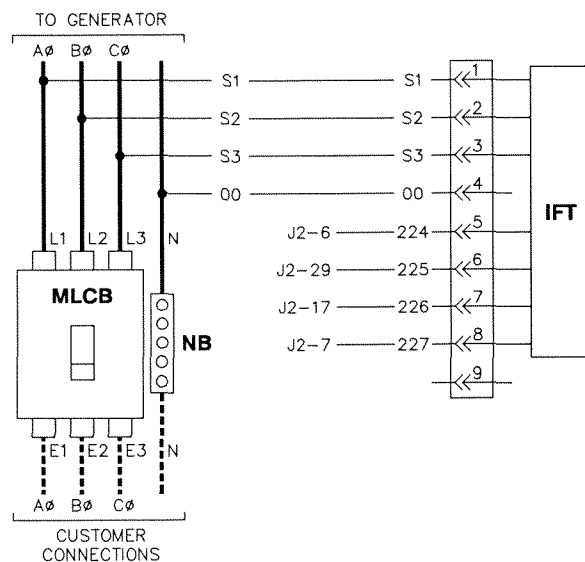
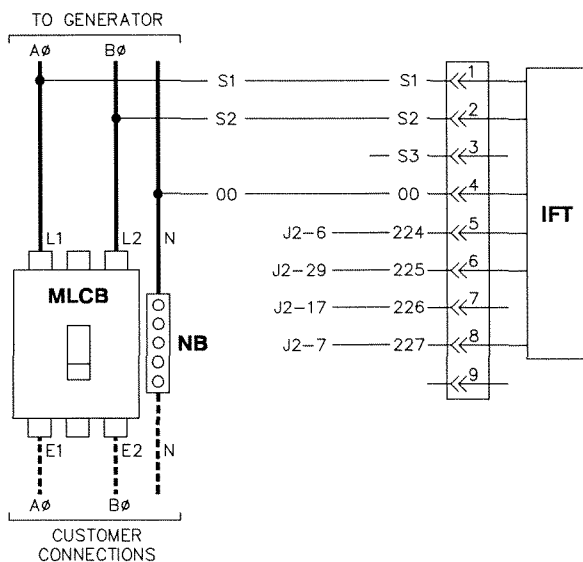

COMPONENTS LOCATED IN HIGH VOLTAGE CUSTOMER CONNECTION MODULE

NOTE: ALL WIRES ON THIS PAGE ARE 600V RATED

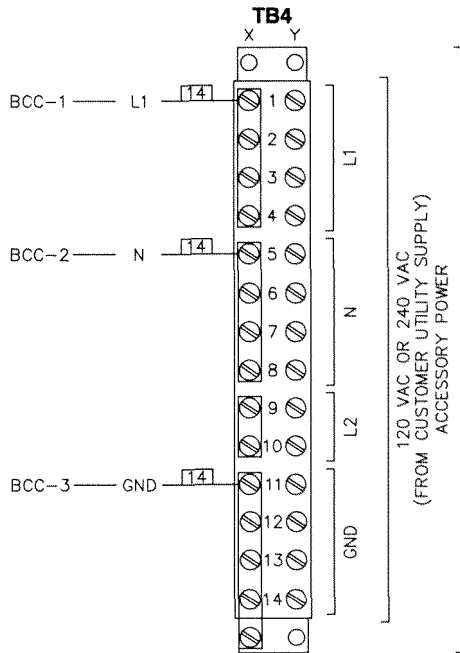

NOTE:  
FOR FIELD WIRING TO CUSTOMER CONNECTIONS  
(TERMINAL STRIP)  
MAXIMUM WIRE SIZE: #10 AWG  
RECOMMENDED TIGHTENING TORQUE: 14 LB-IN

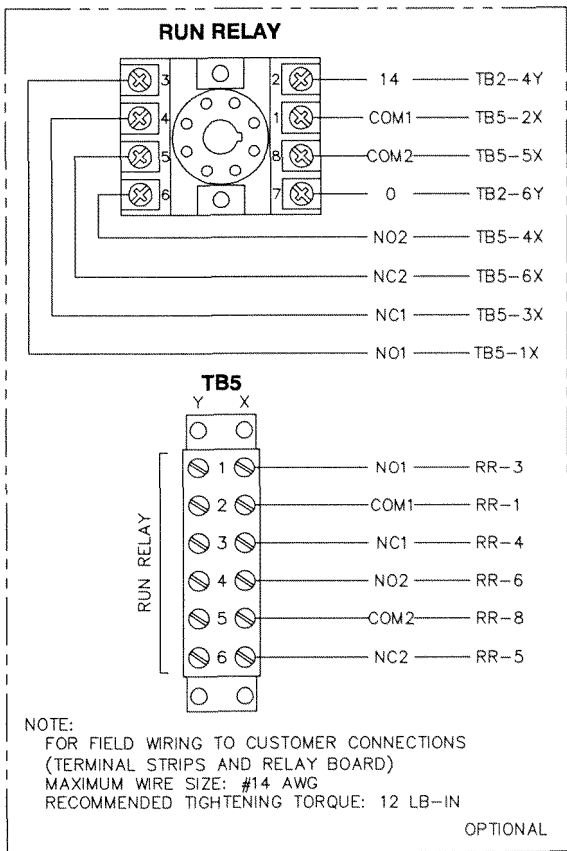
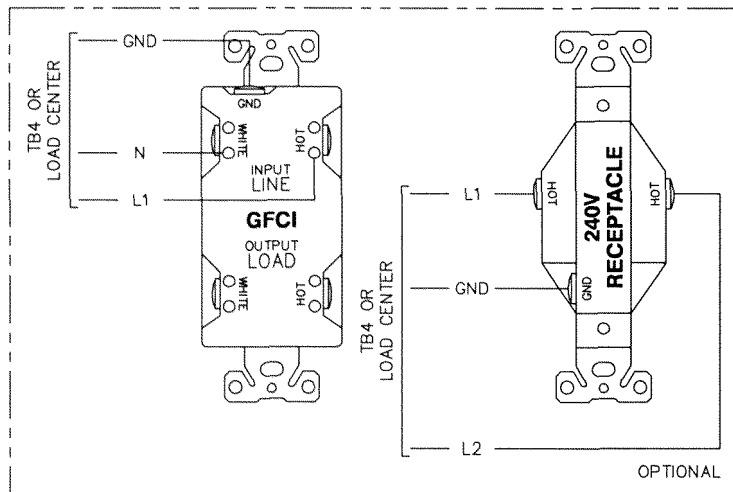
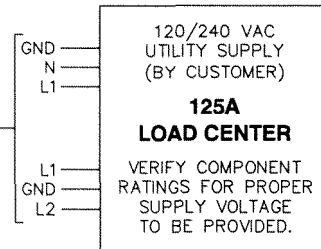

NOTE:  
FOR FIELD WIRING TO CUSTOMER CONNECTIONS  
(TERMINAL STRIPS AND RELAY BOARD)  
MAXIMUM WIRE SIZE: #14 AWG  
RECOMMENDED TIGHTENING TORQUE: 12 LB-IN

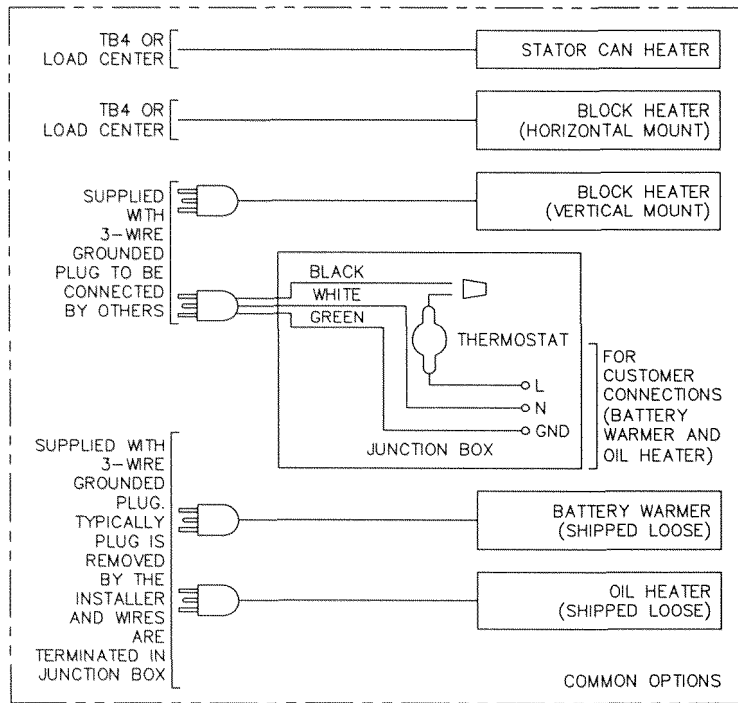

## COMPONENTS LOCATED ON LOW VOLTAGE CUSTOMER CONNECTION PANEL

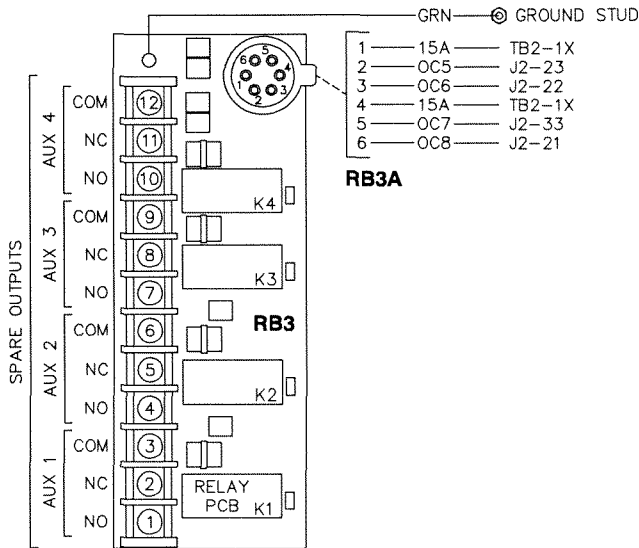

CUSTOMER CONNECTIONS

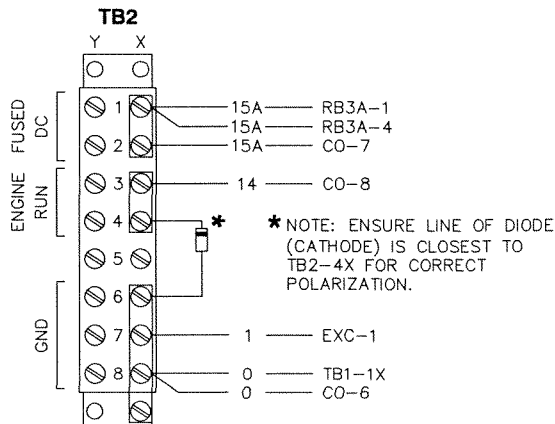
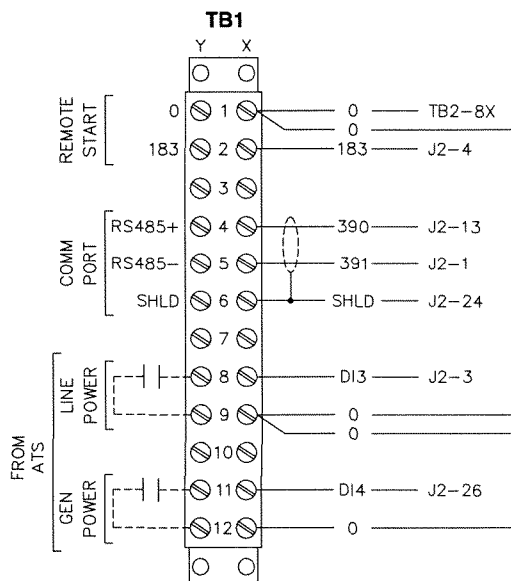

NOTE:  
FOR FIELD WIRING TO CUSTOMER CONNECTIONS  
(TERMINAL STRIPS AND RELAY BOARD)  
MAXIMUM WIRE SIZE: #14 AWG  
RECOMMENDED TIGHTENING TORQUE: 12 LB-IN

## COMPONENTS LOCATED IN CONTROL PANEL

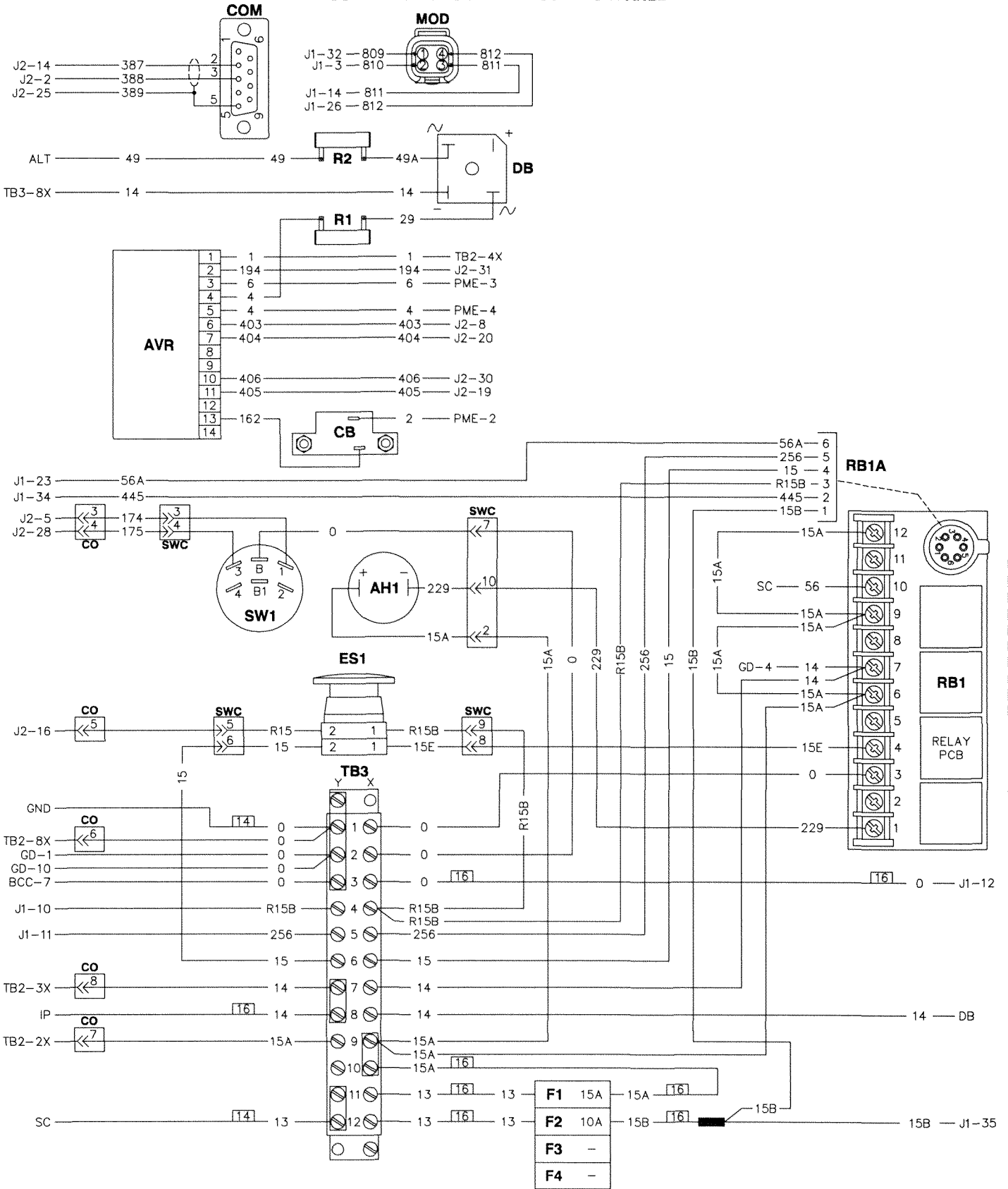



COMPONENTS LOCATED ON ENGINE

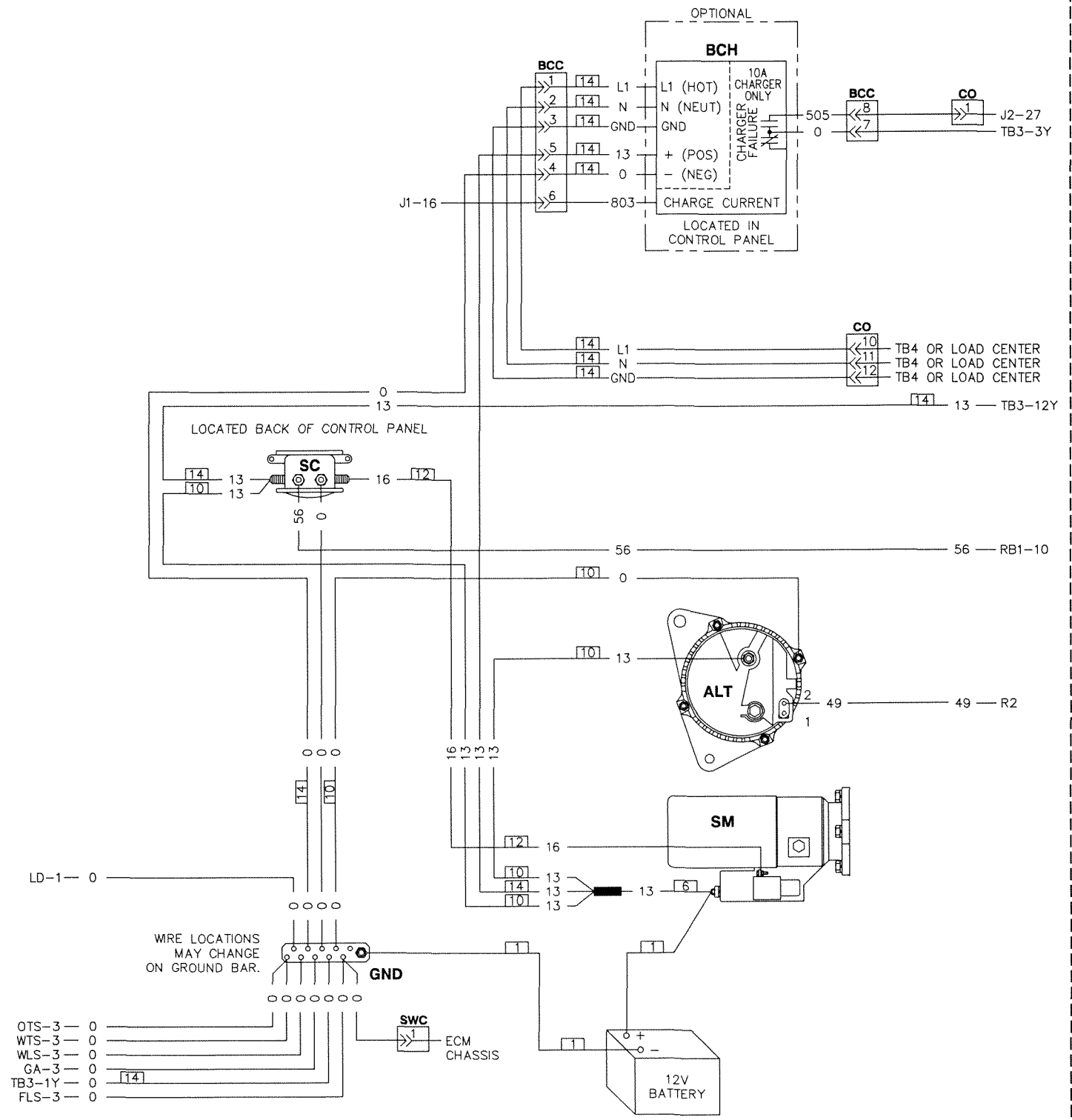

COMPONENTS LOCATED ON ENGINE

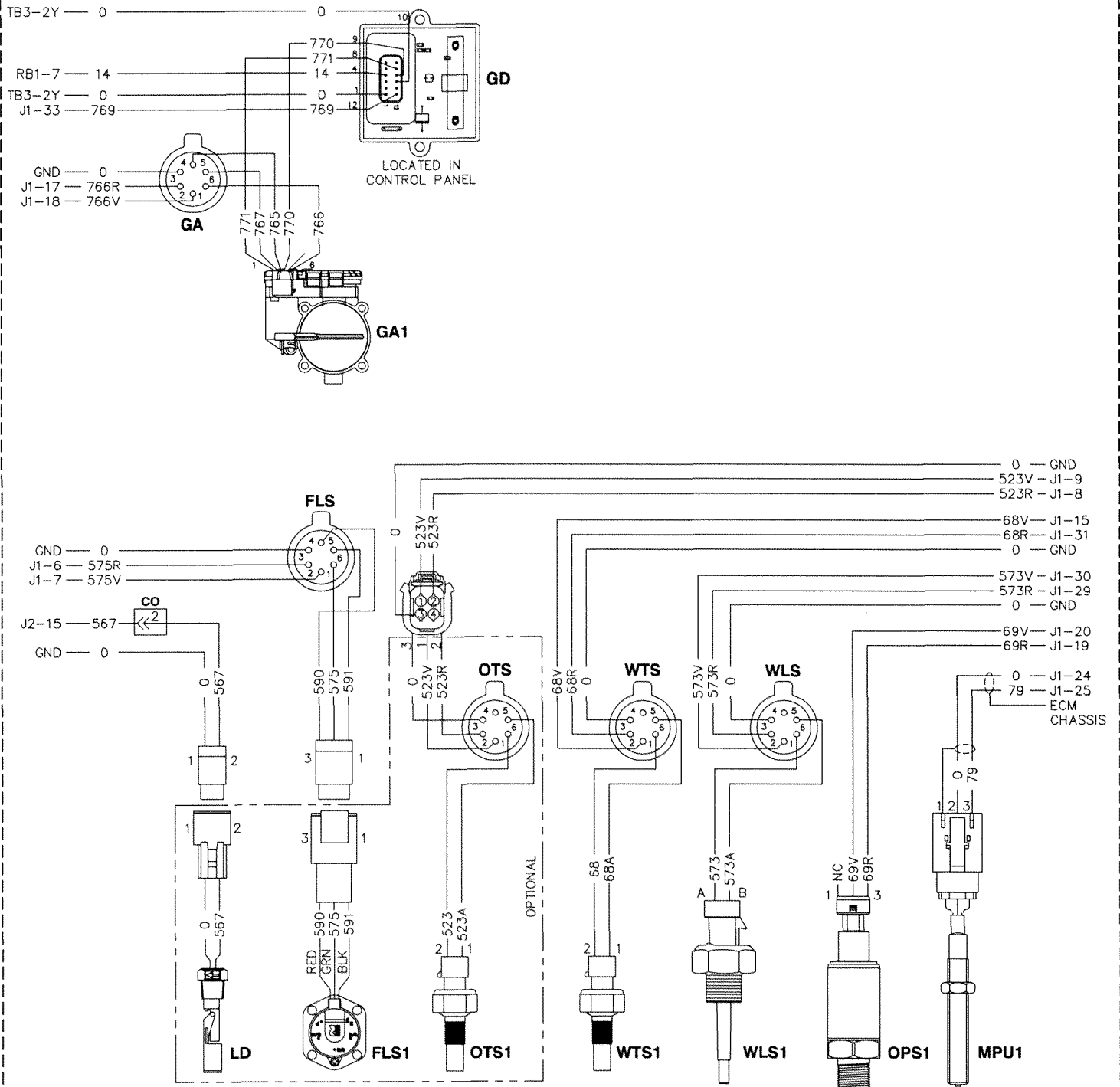

# GROUP G

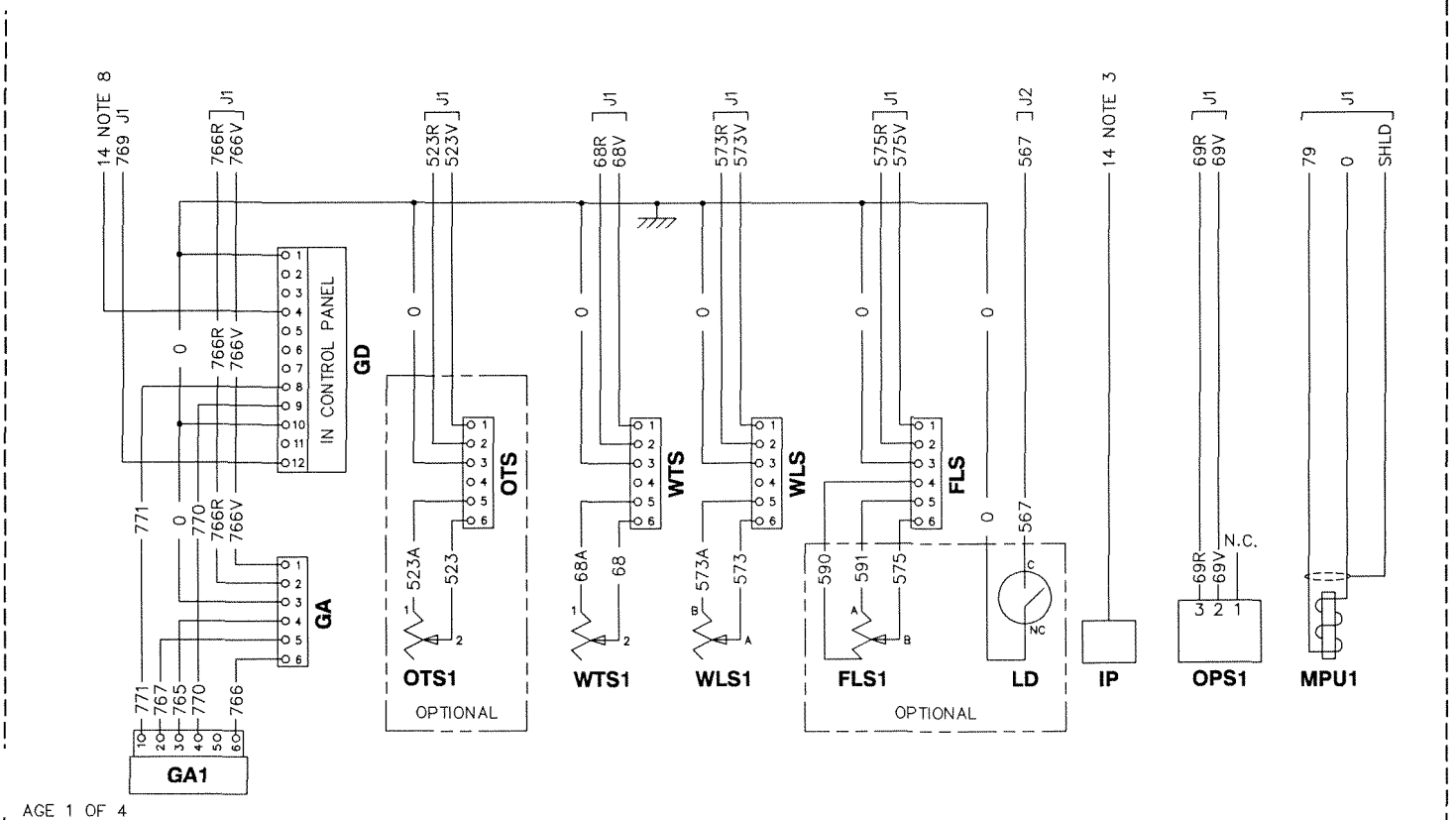
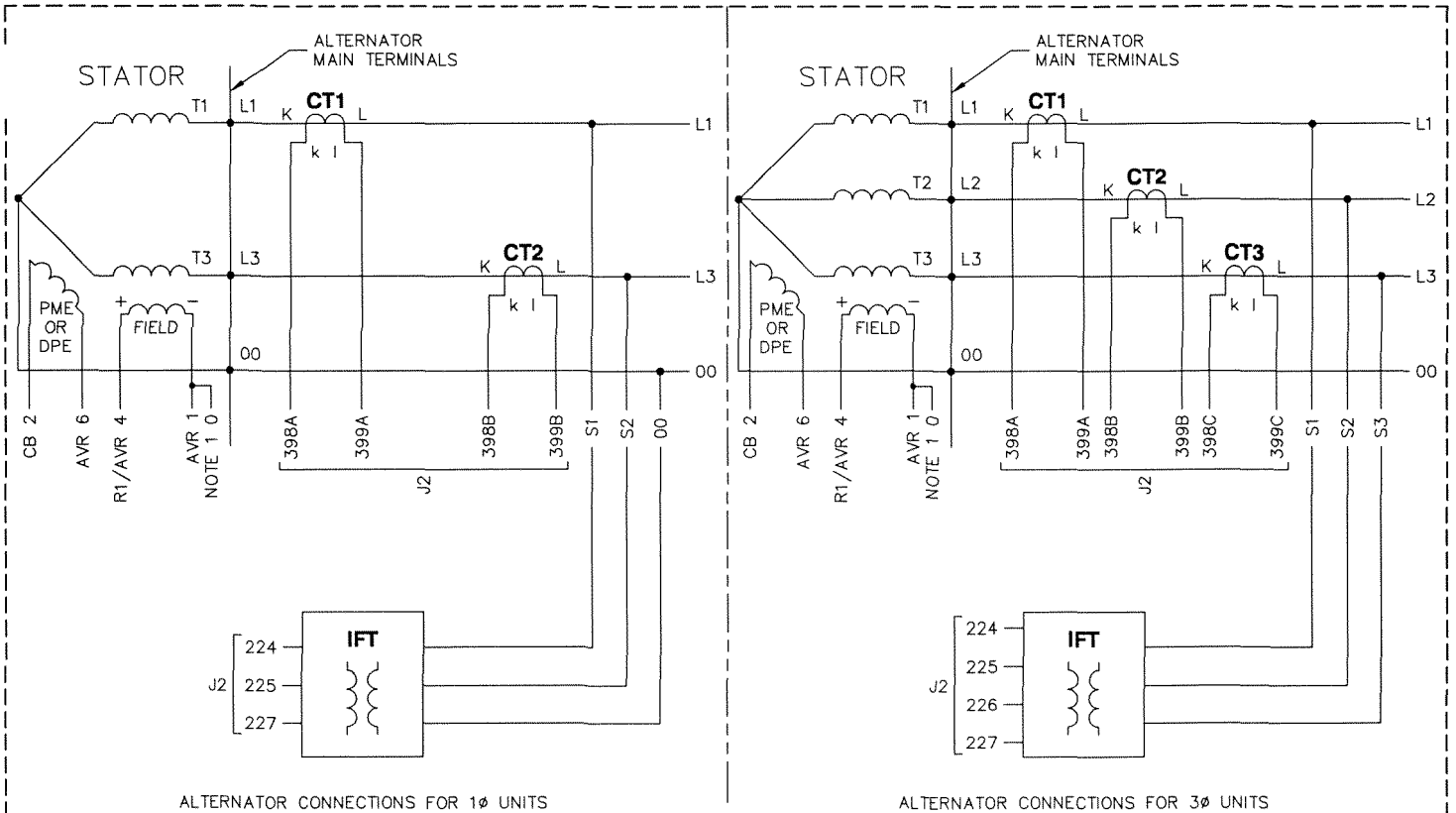

SCHMATIC - DIAGRAM  
 D4.5L/D6.7L G17 12V  
 DRAWING #: 0H9863

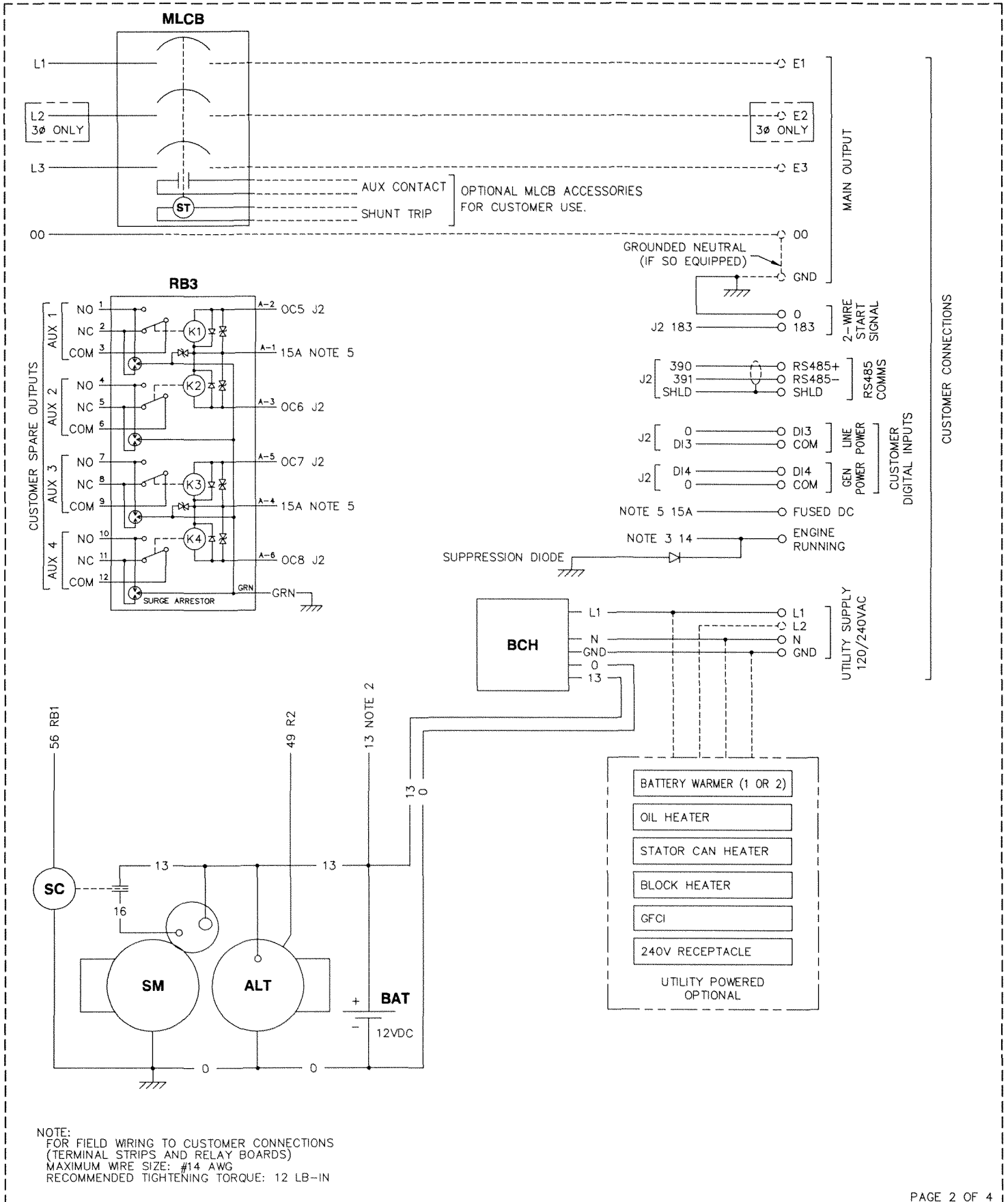

NOTE:  
 FOR FIELD WIRING TO CUSTOMER CONNECTIONS  
 (TERMINAL STRIPS AND RELAY BOARDS)  
 MAXIMUM WIRE SIZE: #14 AWG  
 RECOMMENDED TIGHTENING TORQUE: 12 LB-IN

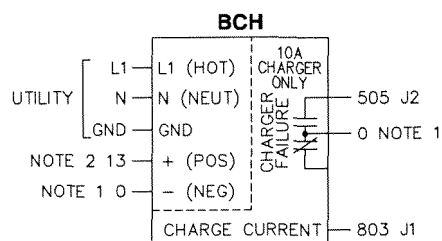
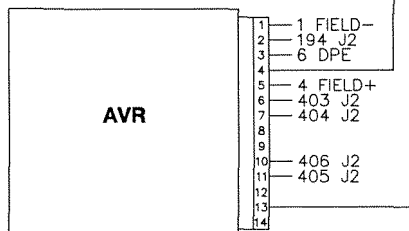
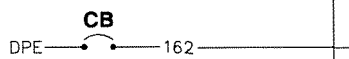
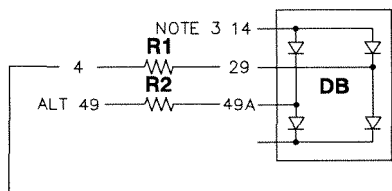
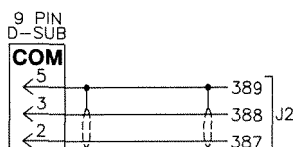
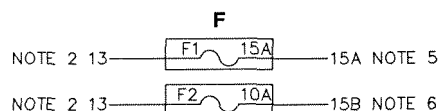
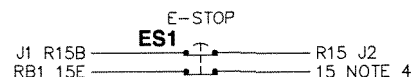
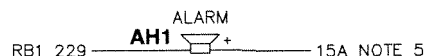
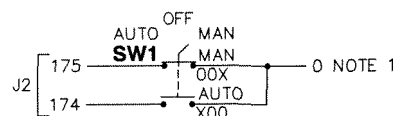
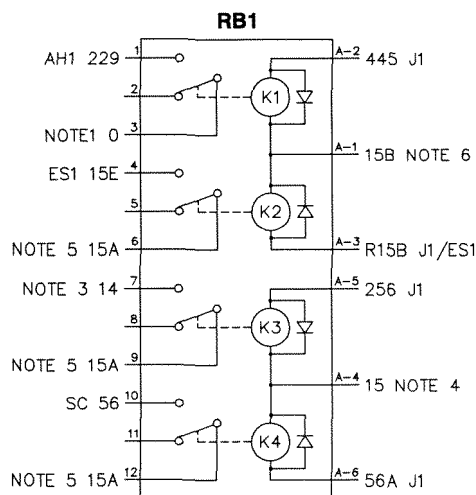

**LEGEND**

00 - NEUTRAL	DB - DIODE BRIDGE	IP - INJECTION PUMP	RB_ - RELAY BOARD
AH1 - ALARM HORN	DPE - EXCITER	J_ - ENGINE CONTROL MODULE CONN.	SC - STARTER CONTACTOR
ALT - DC CHARGE ALTERNATOR	ES1 - EMERGENCY STOP SWITCH	LD - LEAK DETECTOR	SM - STARTER MOTOR
AVR - AUTO VOLTAGE REGULATOR	F_ - FUSE	MLCB - MAIN LINE CIRCUIT BREAKER	SW1 - OFF/AUTO/MANUAL SWITCH
BAT - BATTERY	FLS_ - FUEL LEVEL SENDER	MPU1 - MAGNETIC PICKUP	WLS_ - COOLANT LEVEL SENSOR
BCH - BATTERY CHARGER	GA_ - GOVERNOR ACTUATOR	OPS1 - OIL PRESSURE SENDER	WTS_ - COOLANT TEMPERATURE SENDER
CB - CIRCUIT BREAKER	GD - GOVERNOR DRIVER	OTS_ - OIL TEMPERATURE SENDER	
COM - COMMUNICATION CONNECTOR	GFCI - GROUND FAULT CIRCUIT INTERRUPT	PME - PERMANENT MAGNET EXCITER	
CT_ - CURRENT TRANSFORMER	IFT - INTERFACE TRANSFORMER	R_ - RESISTOR	

**AVR CONNECTOR**

PIN	WIRE	TO	FUNCTION
1	1	FIELD	-- FIELD
2	194	J2-31	+12VDC
3	6	DPE	DPE OUTPUT
4	4	R1/FIELD	+ FIELD
5	4	R1/FIELD	+ FIELD
6	403	J2-8	GATE TRIGGER B
7	404	J2-20	GATE TRIGGER A
10	406	J2-30	ZERO CROSSING I/P
11	405	J2-19	GROUND (ISO)
13	162	CB	DPE OUTPUT (AFTER CB)

**GD CONNECTOR**

PIN	WIRE	TO	FUNCTION
1	0	GND	NOTE 1
4	14	RB1-7	NOTE 3
8	771	GA1-1	THROTTLE DRIVE LO
9	770	GA1-4	THROTTLE DRIVE HI
10	0	GND	NOTE 1
12	769	J1-33	THROTTLE PWM

**ENGINE CONTROL MODULE CONNECTIONS**

**J1**

PIN	WIRE	TO	FUNCTION
3	810	MOD-2	MODEM SIGNAL RETURN
6	575R	FLS-2	FUEL LEVEL RTN
7	575V	FLS-1	FUEL LEVEL +
8	523R	OTS-2	OIL TEMPERATURE RTN
9	523V	OTS-1	OIL TEMPERATURE +
10	R15B	RB1A-3/ES1	OVERSPEED/WATCHDOG
11	256	RB1A-5	FUEL RELAY
12	0	GND	NOTE 1
14	811	MOD-3	MODEM DATA CARRIER DETECT
15	68V	WTS-1	COOLANT TEMP +
16	803	BCH	BAT CHARGER CURRENT
17	766R	GA-2	THROTTLE POS RTN
18	766V	GA-1	THROTTLE POS +
19	69R	OPS1-3	OIL PRESS RTN
20	69V	OPS1-2	OIL PRESS +
23	56A	RB1A-6	STARTER RELAY
24	0	MPU1-2	MPU1 SIGNAL (-)
25	79	MPU1-3	MPU1 SIGNAL (+)
26	812	MOD-4	MODEM ENABLE
29	573R	WLS-2	COOLANT LVL RTN
30	573V	WLS-1	COOLANT LVL +
31	68R	WTS-2	COOLANT TEMP RTN
32	809	MOD-1	MODEM 12V POWER
33	769	GD-12	THROTTLE PWM
34	445	RB1A-2	ALARM RELAY
35	15B	F2	NOTE 6

**J2**

PIN	WIRE	TO	FUNCTION
1	391	CUST CON	RS485- (XFER SW)
2	388	COM-3	RS232 TX (GENLINK)
3	DI3	CUST CON	SPARE IN 3/LINE PWR
4	183	CUST CON	REMOTE START
5	174	SW1	"AUTO" START
6	224	IFT	V SENSE GEN A PH
7	227	IFT	V SENSE RTN
8	403	AVR-6	AVR GATE TRIGGER B
9	399C	CT3	GEN C PH CURRENT -
10	398C	CT3	GEN C PH CURRENT +
11	399A	CT1	GEN A PH CURRENT -
12	398A	CT1	GEN A PH CURRENT +
13	390	CUST CON	RS485+ (XFER SW)
14	387	COM-2	RS232 RX (GENLINK)
15	567	LD	LEAK DETECTOR
16	R15	ES1	EMERGENCY STOP
17	226	IFT	V SENSE GEN C PH
19	405	AVR-11	AVR GROUND
20	404	AVR-7	AVR GATE TRIGGER A
21	OC8	RB3A-6	SPARE OUTPUT 4
22	OC6	RB3A-3	SPARE OUTPUT 2
23	OC5	RB3A-2	SPARE OUTPUT 1
24	SHLD	CUST CON	RS485 DRAIN (XFER SW)
25	389	COM-5	RS232 COM (GENLINK)
26	DI4	CUST CON	SPARE IN 4/GEN PWR
27	505	BCH	BAT CHARGER FAIL
28	175	SW1	"MANUAL" START
29	225	IFT	V SENSE GEN B PH
30	406	AVR-10	AVR ZERO CROSSING I/P
31	194	AVR-2	AVR +12VDC
33	OC7	RB3A-5	SPARE OUTPUT 3
34	399B	CT2	GEN B PH CURRENT-
35	398B	CT2	GEN B PH CURRENT+

\* - CONNECTIONS NOT USED IN 1Ø UNITS.

**NOTES:**

- 1) WIRE# 0 IS CHASSIS GROUND (BATTERY-) UNLESS NOTED OTHERWISE.
- 2) WIRE# 13 IS UNFUSED +12VDC (BATTERY+).
- 3) WIRE# 14 IS FUSED +12VDC WHEN GENERATOR IS CRANKING OR RUNNING.
- 4) WIRE# 15 IS FUSED +12VDC WHEN E-STOP IS NOI ACTIVATED.
- 5) WIRE# 15A IS FUSED +12VDC FOR GENERAL USE.
- 6) WIRE# 15B IS FUSED +12VDC FOR THE ENGINE CONTROL MODULE.

# GROUP H

I/N	PART NO.	QTY	DESCRIPTION
1	0H9028	2	DECAL ULTRA LOW SULFER DSL

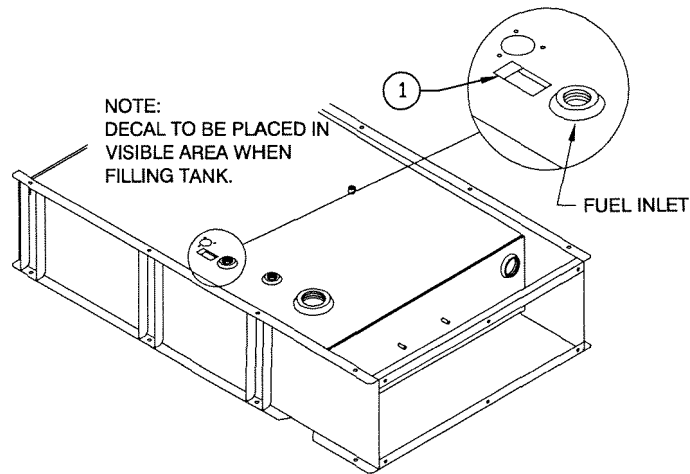

**BASE TANK APPLICATION**

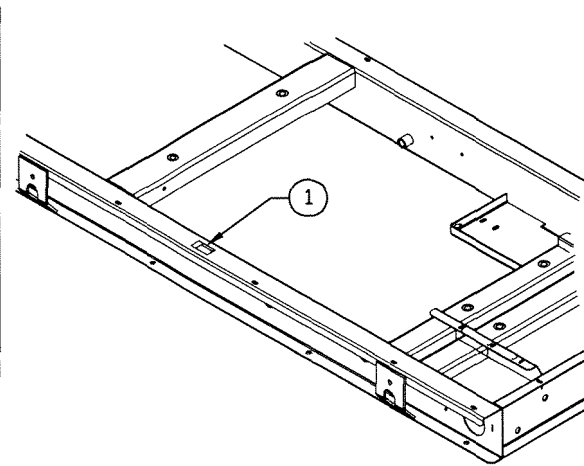

**OPEN SET APPLICATION**

NOTE:  
WHEN USING EXTERNAL FUEL SOURCE  
DECAL MUST BE APPLIED IN VISIBLE  
AREA OF FUEL FILL.

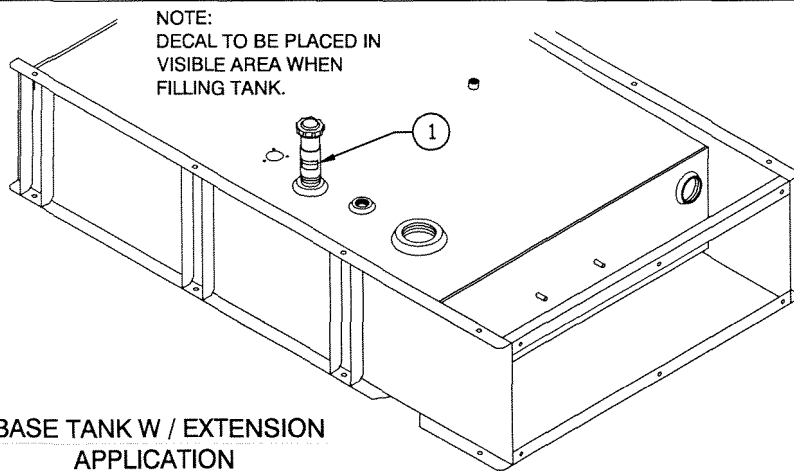

**BASE TANK W / EXTENSION  
APPLICATION**

NOTE:  
DECAL TO BE PLACED  
ON DOOR USED TO FILL  
FUEL.

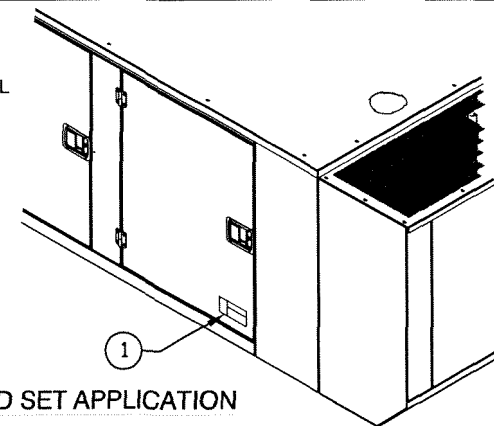

**CLOSED SET APPLICATION**

EXPLODED VIEW: LOW SULFUR FUEL

DRAWING #: 0G8716

APPLICABLE TO:

GROUP H

**THIS PAGE IS LEFT INTENTIONALLY BLANK**



# GROUP H

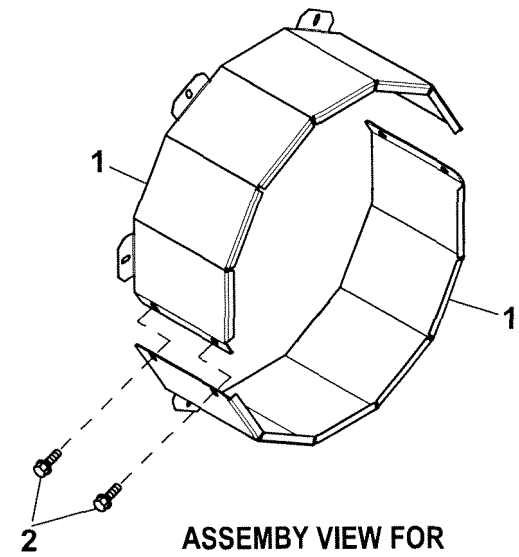
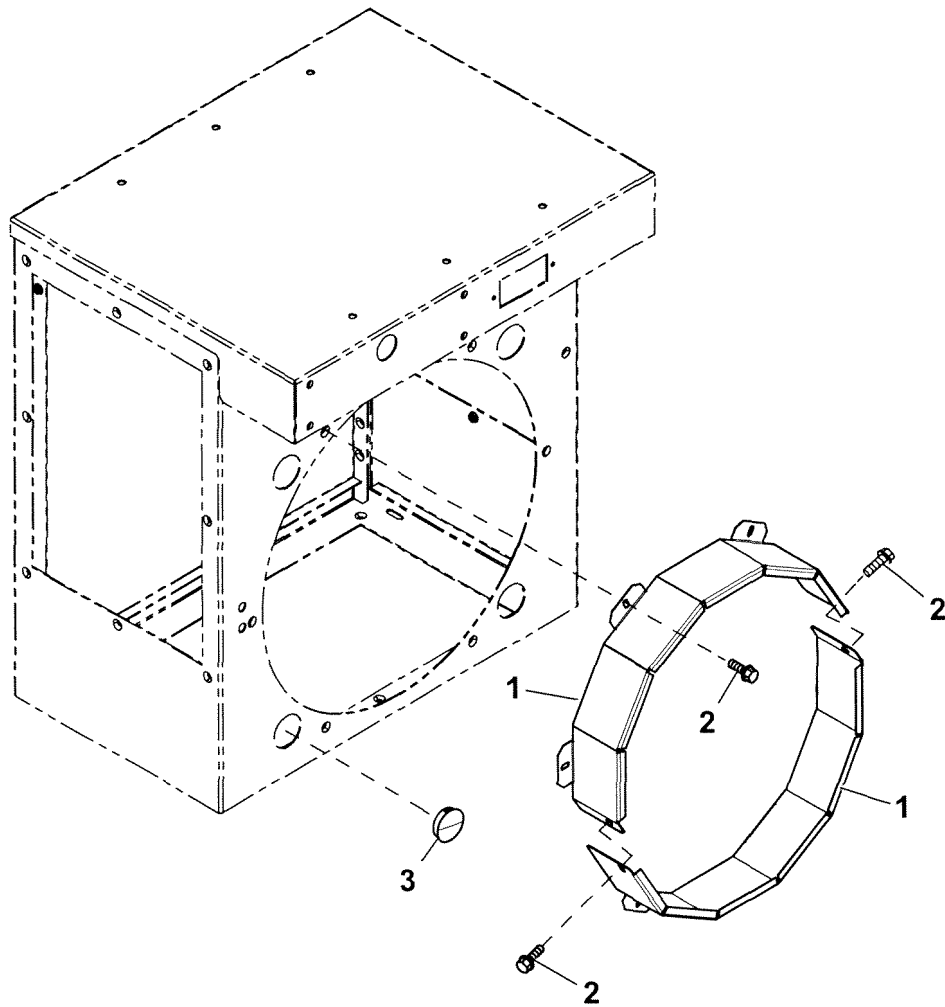

**ASSEMBY VIEW FOR  
SHROUD 0H78890ST03 ONLY**

**EXPLODED VIEW: EV 390 ALT SHROUD KIT**

**DRAWING #: 0H5179**

**GROUP H**

**APPLICABLE TO:**

ITEM	PART#	QTY.	DESCRIPTION
(1)1	0H47970ST03	2	SHROUD 390 ALT X 76MM
	0H4797AST03	2	SHROUD 390 ALT X 50MM
	0H4797BST03	2	SHROUD 390 ALT X 100MM
	0H78890ST03	2	SHROUD 390 ALT X 150MM
(2)2	0C2454	8/10	SCREW HWHT M6-1 X 16 N WA Z/JS
3	0E1534A	4	PLUG PLASTIC 1.50"

(1)NOTE:

0H47970ST03 INCLUDED IN KIT #0H5178  
0H4797AST03 INCLUDED IN KIT #0H5178A  
0H4797BST03 INCLUDED IN KIT #0H5178B  
0H78890ST03 INCLUDED IN KIT #0H5178C

(2) QTY DETERMINED BY SHROUD MOUNTING REQUIREMENTS.

# GROUP H

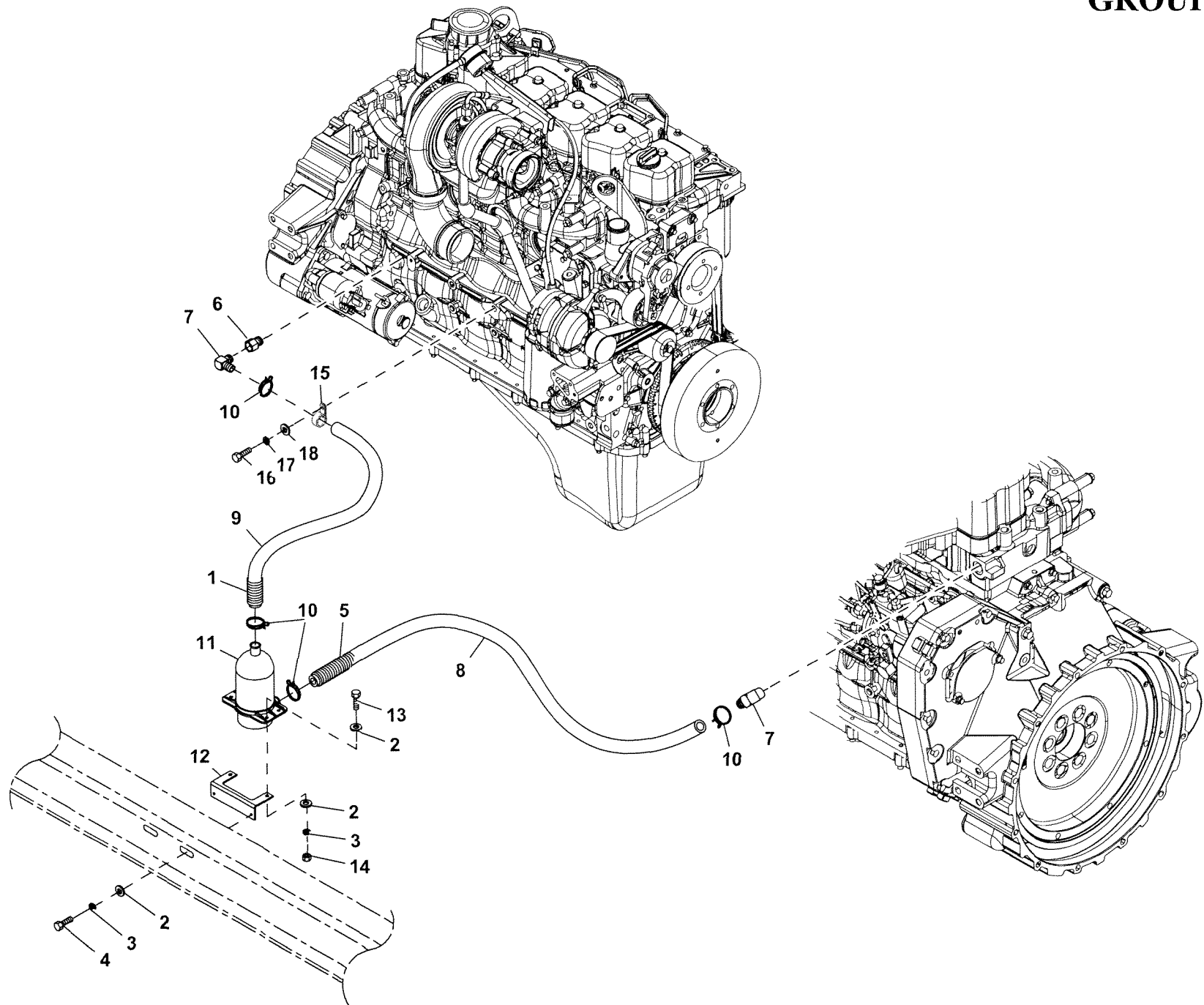

EXPLODED VIEW: BLK HTR D6.7L G17 100/130KW

DRAWING #: 0H5980

GROUP H

APPLICABLE TO:

ITEM	PART#	QTY.	DESCRIPTION
1	077043E	1	CONDUIT FLEX 1.0" ID (23"LG)
2	022473	6	WASHER FLAT 1/4-M6 ZINC
3	022097	4	WASHER LOCK M6-1/4
4	047411	2	SCREW HHC M6-1.0 X 16 C8.8
5	077043E	1	CONDUIT FLEX 1.0" ID (46" LG)
6	0A4707E	1	ADAPTER 3/8NPT X M18-1.5
7	034339	2	BARBED EL 90 3/8NPT X 5/8
8	050967	1	HOSE COOL 5/8 ID 20R3 (46" LG)
9	050967	1	HOSE COOL 5/8 ID 20R3 (23" LG)
10	0G0015	4	CLAMP HOSE 7/8" OD DOUBLE WIRE
11	084918H	1	HEATER BLOCK 1500W 240V
	084918L	1	HEATER BLOCK 1500W 120V
12	084427	1	BRACKET HEATER WWELDNUTS
13	042568	2	SCREW HHC M6-1.0 X 20 C8.8
14	049813	2	NUT HEX M6 X 1.0 G8 YEL CHR
15	055934P	1	CLAMP STL/VNL 1.62 X .486
16	051768	1	SCREW HHC M12-1.75 X 25 C8.8
17	051769	1	WASHER LOCK M12
18	049808	1	WASHER FLAT M12

# GROUP H

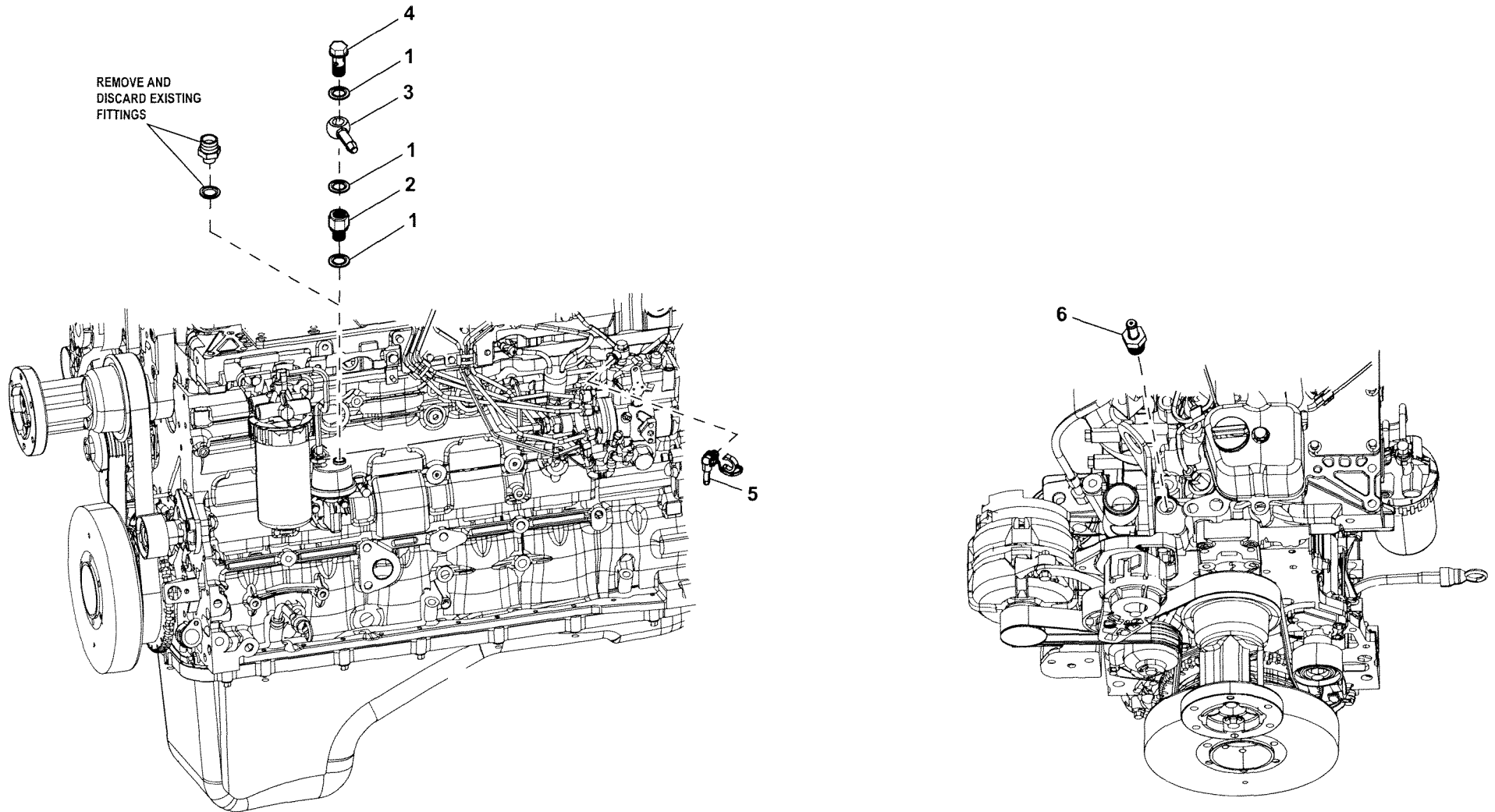

**EXPLODED VIEW: 4.5L 60KW G17 ENGINE KIT**

**DRAWING #: 0H6009B**

**GROUP H**

**APPLICABLE TO:**

<b>ITEM</b>	<b>PART#</b>	<b>QTY.</b>	<b>DESCRIPTION</b>
1	0H6298	3	WASHER
2	0H6299	1	THREADED UNION
3	0H6297	1	SWIVEL COUPLING
4	0H6295	1	BANJO BOLT M12-1.5 X 25
5	0H6296	1	ELBOW COUPLING
6	0H6349	1	PIPE SOCKET

# GROUP H

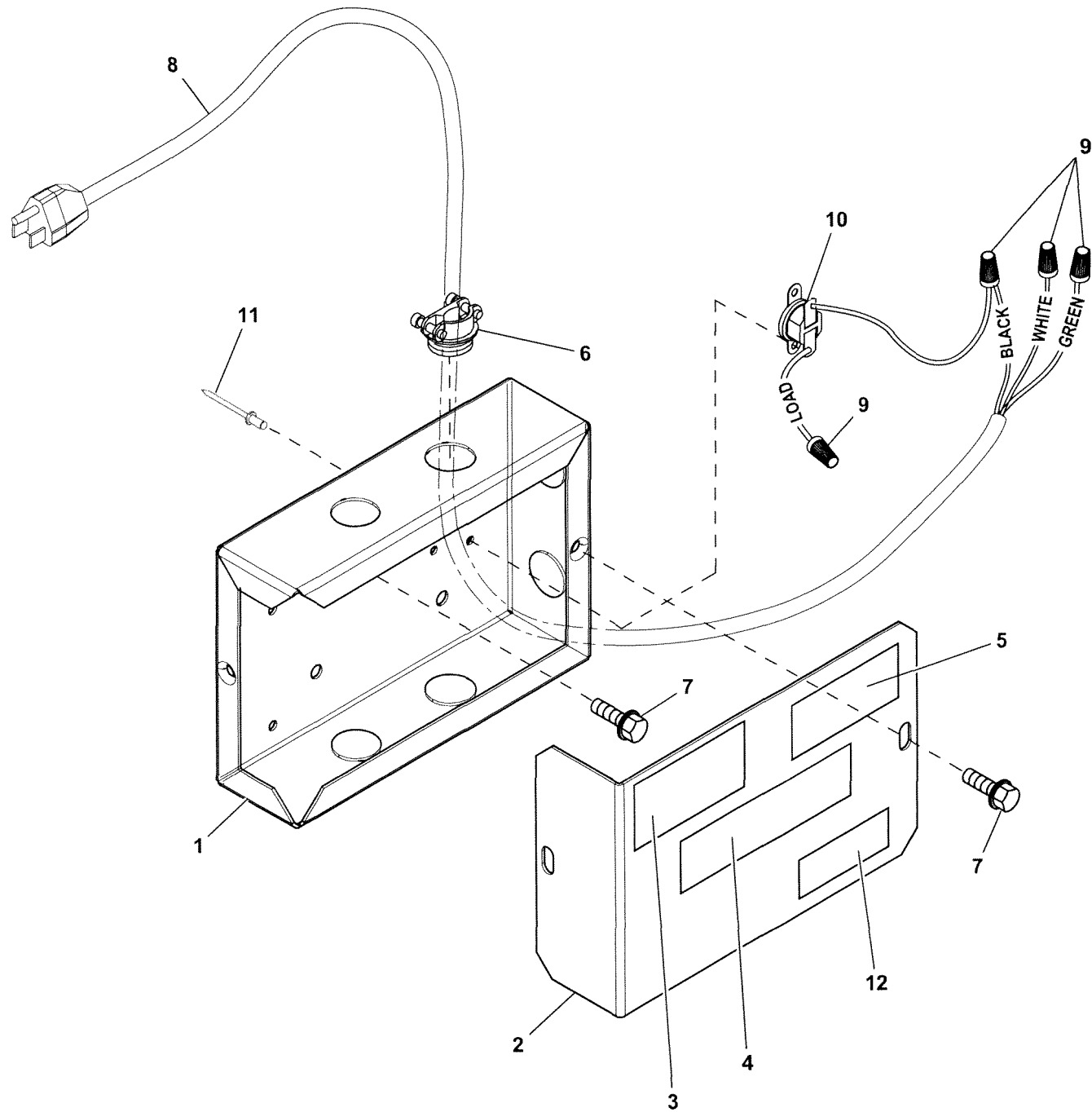

**EXPLODED VIEW: EV HEATER PREP KIT**

**DRAWING #: 0H8028**

**GROUP H**

**APPLICABLE TO:**

ITEM	PART#	QTY.	DESCRIPTION
1	0H55060ST03	1	JUNCTION BOX
2	0H55070ST03	1	JUNCTION BOX COVER
(2)3	0G5704B	1	DECAL OIL WARMER CONNECTION
4	0G3546	1	DECAL WRN BATT CHRG 12/24V
(1)5	0G5704	1	DECAL BATT WARMER CONNECTION
6	022206	1	FITTING CONDUIT STR 3/8
7	0E3257	4	SCREW HWHTF M6-1.0 X 16
8	0E6187	1	CORD,POWER SUPPLY 16 AWG X 9'
9	027959	4	WIRE NUT #30-451 YEL
10	052010	1	ASSY THERMOSTAT AND LEAD
11	036261	2	RIVET POP .125 X .275 SS
12	0H8147	1	DECAL HEATER PREP KIT

(1)PARTS INCLUDED IN OPTIONAL BATTERY WARMER KIT.

(2)PARTS INCLUDED IN OPTIONAL OIL WARMER



# GROUP H

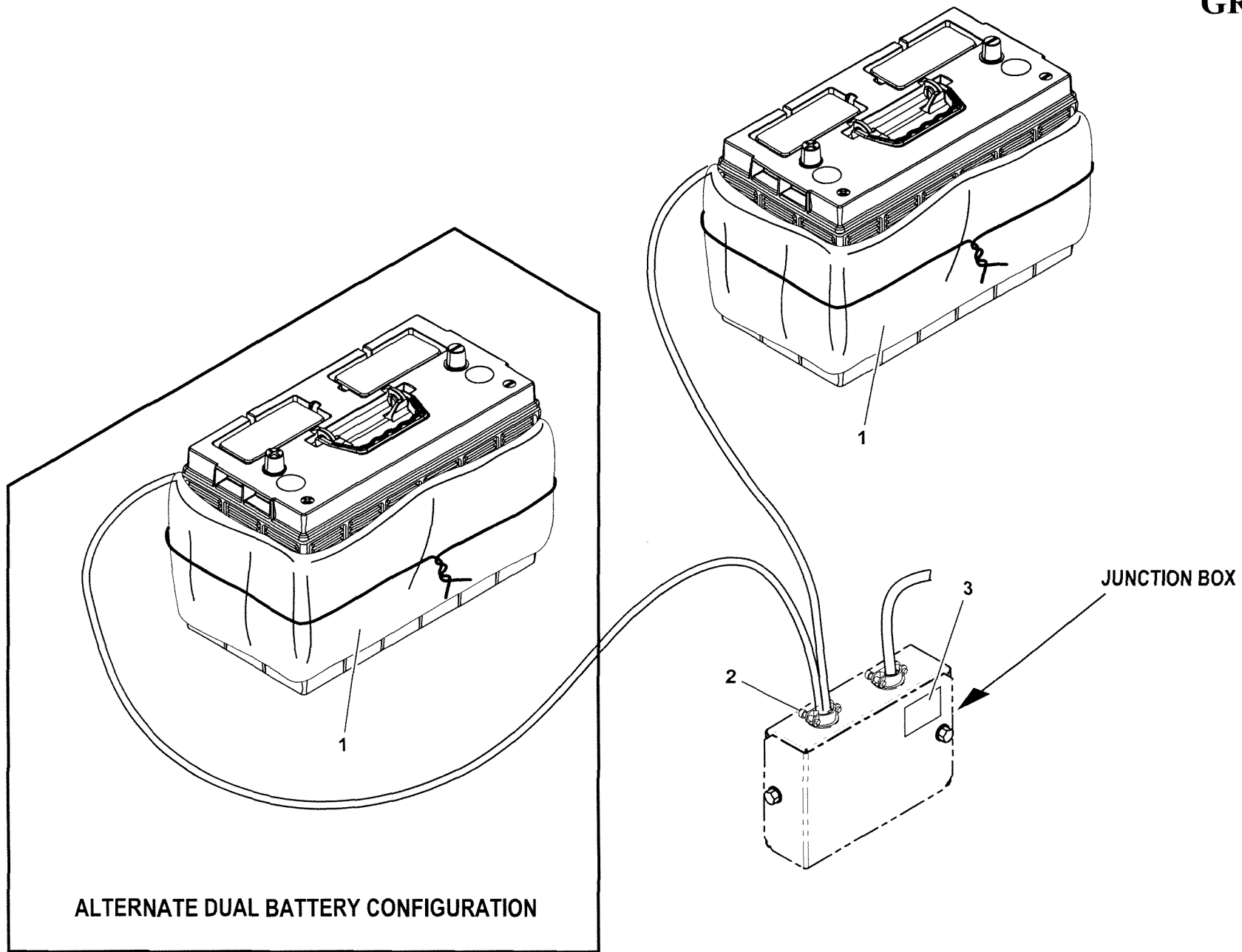

**EXPLODED VIEW:**  
**DRAWING #:0H8060**  
**APPLICABLE TO:**

## GROUP H

ITEM	PART#	QTY.	DESCRIPTION
1	057148A	2	BATTERY WARMER 36" 80W 120V
2	022206	1	FITTING CONDUIT STR 3/8
3	0G5704	1	DECAL BATT WARMER CONNECTION

### Battery Heater Connection

1. Disconnect battery cables to prevent accidental start-up. Disconnect the negative battery cable first from the battery post indicated by (-) or NEG.
2. Make sure power is off from the appropriate power source.
3. To connect the wires, hold the bare metal leads together and place a wire nut over them, then twist clockwise until tight. For all these connections, use the wires nuts provided.
4. Connect the ground wire from 120V power source to the ground wire from battery heater.
5. Using wire nuts provided connect the white wire and black wire from the battery heater as follows:
  - The white (common) power wire from 120V power source to 1st wire from the battery heater.
  - The wire from load side of thermostat to 2nd wire from the battery heater.

**CAUTION: Be sure no bare wire or wire strands are visible after making connections.**

6. Push all wires and wire nuts into junction box.
7. Assemble junction box cover to junction box.
8. Reconnect battery cables to battery posts. Connect the positive cable first to the battery post indicated by (+) or POS.

# GROUP H

250A

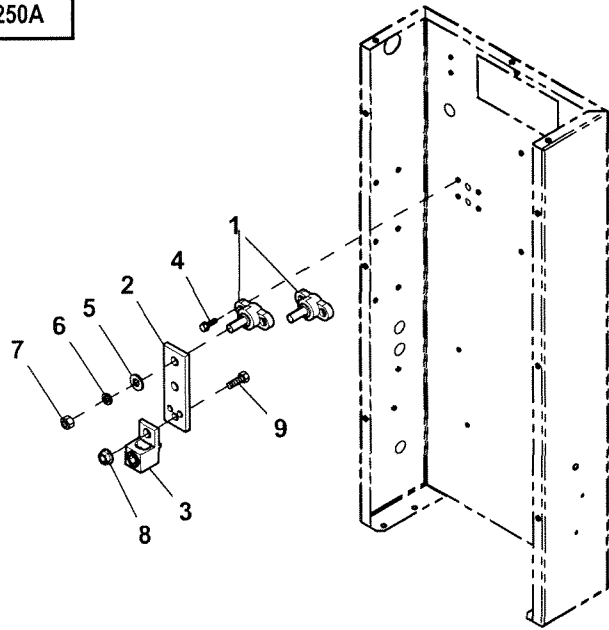

300-600A

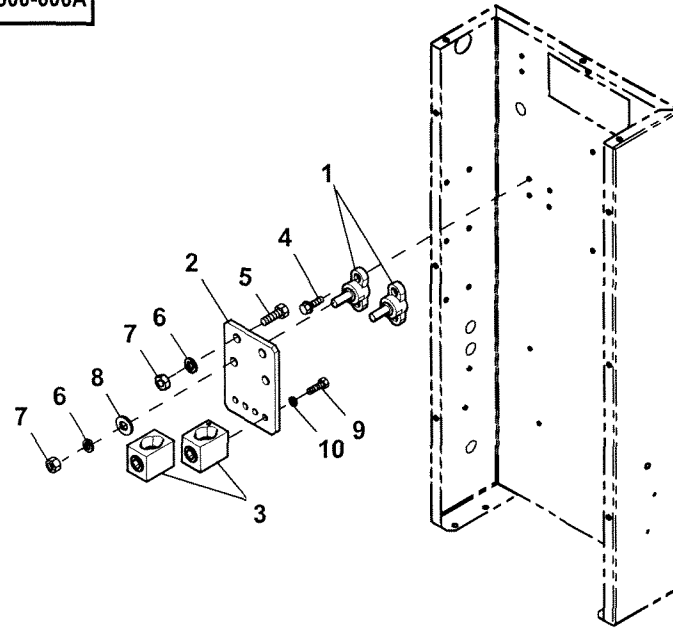

700-1200A

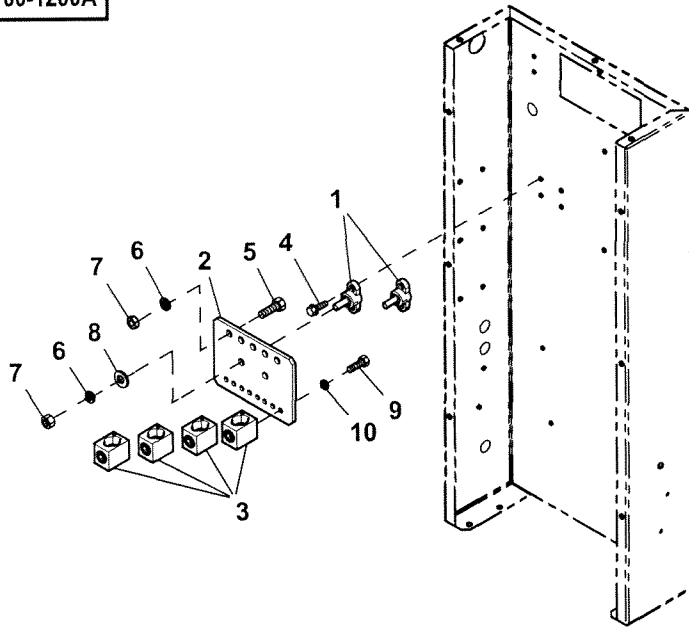

1400-2500A

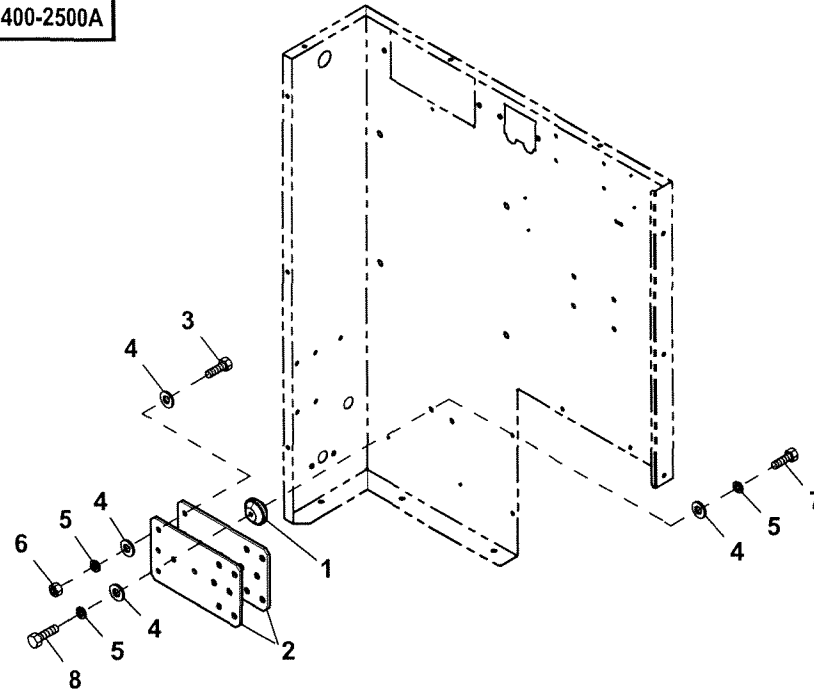

**EXPLODED VIEW: EV, NEUTRAL BLOCK 0-250A**

**DRAWING #: 0J1047**

**GROUP H**

**APPLICABLE TO:**

ITEM	PART#	QTY.	DESCRIPTION
NEUTRAL BLOCK (250A)			
1	057073	2	JUNCTION BLOCK 3/8-16
2	0H9690	1	NEUTRAL, BRACKET (60-100A)
3	0F8451	1	LUG SLDLSS 300 MCM-6 AL/CU
4	0C2266	4	SCREW PHTT M5-0.8 X 16 ZP
5	022131	2	WASHER FLAT 3/8-M10 ZINC
6	022237	2	WASHER LOCK 3/8
7	022241	2	NUT HEX 3/8-16 STEEL
8	067989	1	NUT HEX FL WHIZ M8-1.25
9	043107	1	SCREW HHC M8-1.25 X 25 C8.8
NEUTRAL BLOCK (300A - 600A)			
1	057073	2	JUNCTION BLOCK 3/8-16
2	0H9689A	1	BUS BAR, NTRL BLK 520 0-600A
3	0A7822	2	LUG SLDLSS 600/250-1/0X1/4-28
4	0C2266	4	SCREW PHTT M5-0.8 X 16 ZP
5	022511	2	SCREW HHC 3/8-16 X 1-1/4 G5
6	022237	4	WASHER LOCK 3/8
7	022241	4	NUT HEX 3/8-16 STEEL
8	022131	2	WASHER FLAT 3/8-M10 ZINC
9	045335	4	SCREW HHC 1/4-28 X 3/4 G5
10	022097	4	WASHER LOCK M6-1/4
NEUTRAL BLOCK (700A - 1200A)			
1	057073	2	JUNCTION BLOCK 3/8-16
2	0H9689	1	BUS BAR, NTRL BLK 520 600-1600
3	0A7822	4	LUG SLDLSS 600/250-1/0X1/4-28
4	0C2266	4	SCREW PHTT M5-0.8 X 16 ZP
5	022511	5	SCREW HHC 3/8-16 X 1-1/4 G5
6	022237	7	WASHER LOCK 3/8
7	022241	7	NUT HEX 3/8-16 STEEL
8	022131	2	WASHER FLAT 3/8-M10 ZINC
9	045335	8	SCREW HHC 1/4-28 X 3/4 G5
10	022097	8	WASHER LOCK M6-1/4
NEUTRAL BLOCK (1400A - 2500A)			
1	0C6937M	2	INSULATOR, STANDOFF 600V3/8-16
2	0J4583	2	BUS BAR, 1/4"X6"X10"
3	031578	3	SCREW HHC 3/8-16 X 1-1/2 G8
4	022131	10	WASHER FLAT 3/8-M10 ZINC
5	022237	7	WASHER LOCK 3/8
6	022241	3	NUT HEX 3/8-16 STEEL
7	023152	2	SCREW HHC 3/8-16 X 3/4 G5
8	029745	2	SCREW HHC 3/8-16 X 1 G5



**GENERAC® POWER SYSTEMS, INC.**  
211 MURPHY DR. • P.O. BOX 310  
EAGLE, WI 53119